

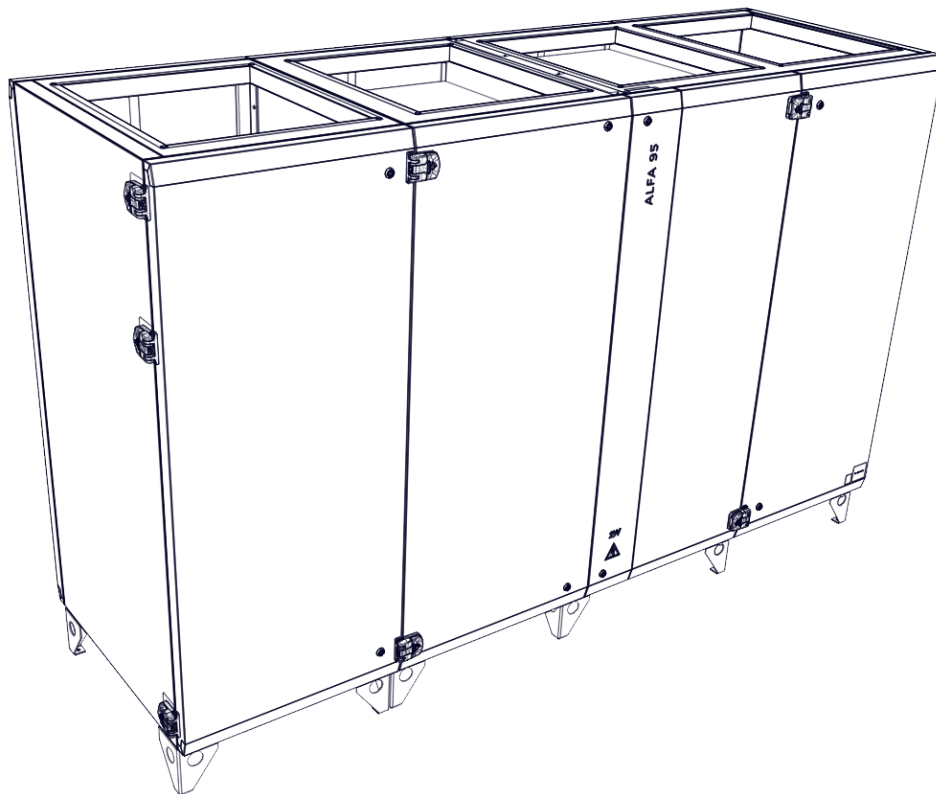

PARTNER
IN VENTILATION
2VV.CZ

EN

HR95 UPPER INSTALLATION







4-118-0431

CE

BEFORE YOU START

For better orientation you will find following symbols in the text hereof. Following table shows symbols and their meaning.

SYMBOL	MEANING
 ATTENTION!	Warning or notification
 READ CAREFULLY!	Important instructions
 YOU WILL NEED	Advices and practical information
 TECHNICAL DATA	Detail technical information
	Link to another part of the user guide

Before installation, please read carefully the guide “**Safety for Ventilation Units**” where you can find instructions for correct and safe operation of the product.

This manual includes important instructions for safe connection of the ventilation unit. Before connecting the unit, please read follow all instructions! The manufacturer reserves the right to make changes including technical documentation without previous notification. Please keep this manual for further references. Consider this manual integral part of the product.

EC DECLARATION OF COMPLIANCE

The product was designed, and manufactured to comply with all relevant provisions and is in compliance with the requirements of the European Parliament and of the Council of the EU, including the amendment, which it was classified under. It is considered safe when installed in the specified conditions and operated according to the instructions of the operations manual. It was assessed according to harmonized European standards listed in the relevant EC declaration of conformity were applied.

For the current and full version of the EC declaration of conformity visit www.2vv.cz

FCC CLASS A CERTIFICATION NOTE:

This equipment has been tested and found to comply with the limits for a Class A digital device under Part 15 of the FCC Rules. These limits are designed to provide reasonable protection against harmful interference when the equipment is operated in a commercial environment. This equipment generates, uses, and can radiate radio frequency energy and, if not installed and used in accordance with the instructions for use, may cause harmful interference to radio communications. Operation of this equipment in a residential area may cause harmful interference, in which case the user will be required to correct the interference at their own expense.

IMPORTANT: Changes or modifications to this product not approved by the manufacturer may result in loss of authority to operate the equipment.

MAIN COMPONENTS

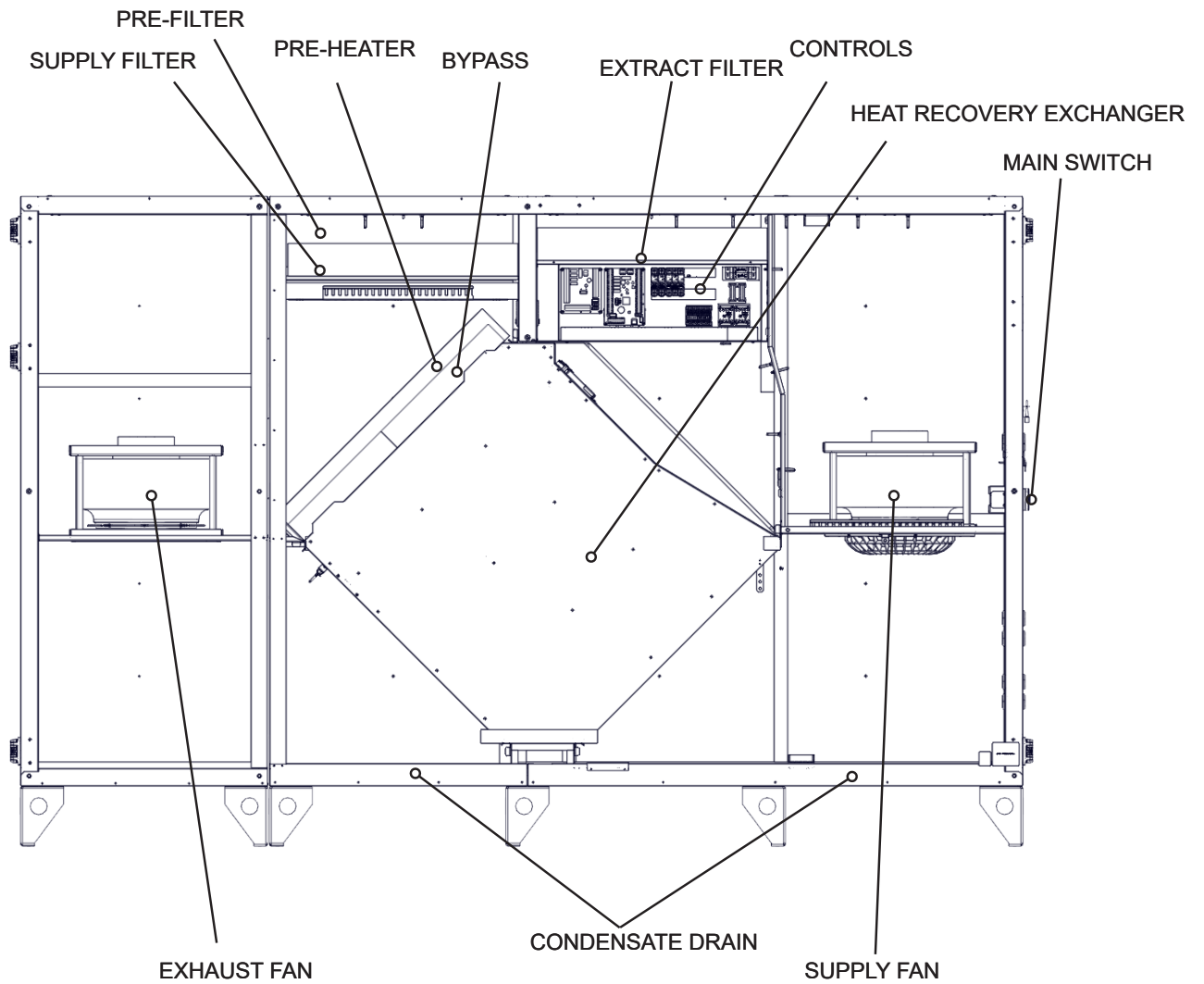

BEFORE YOU START

SELECT UNIT LOCATION

TECHNICAL DATA

The unit is designed for indoor or outdoor installation and can be installed in an outdoor, unprotected environment with a temperature range of -20°C to +60°C.

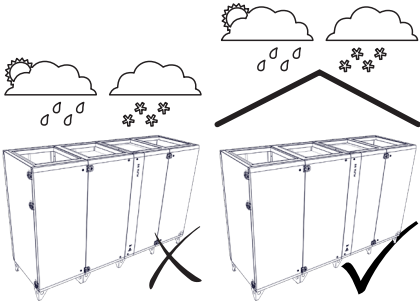

For proper operation, the temperature on the HRV side should range from -20°C to +60°C, with a maximum humidity of 90%. Operation outside these limits may damage the heat exchanger structure. The device is not intended for air containing flammable or explosive mixtures, chemical vapours, heavy dust, soot, grease, toxins, pathogenic organisms, etc.

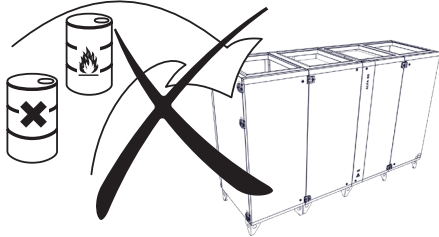

TECHNICAL DATA

All unit models must be installed in an upright position according to the figure below. Any other position is strictly prohibited and will invalidate the warranty

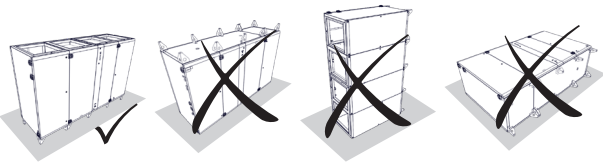

The unit must be installed so that the air inlets and outlets correspond with the direction of the air flows in the ventilation system. The unit must be installed to provide access for maintenance, repairs or disassembly. This includes access to dampers in order to inspect them, access to the controls box inside unit, and unit panels to access interior of the unit for filter changes and other components

SAFE INSTALLATION DISTANCE

ATTENTION!

- All materials used within a distance of less than 100 mm from the ventilation unit must be non-flammable (do not burn, or flare up) or less flammable (do not burn, but decompose – e.g. drywall). These materials must not cover unit inlets and outlets.

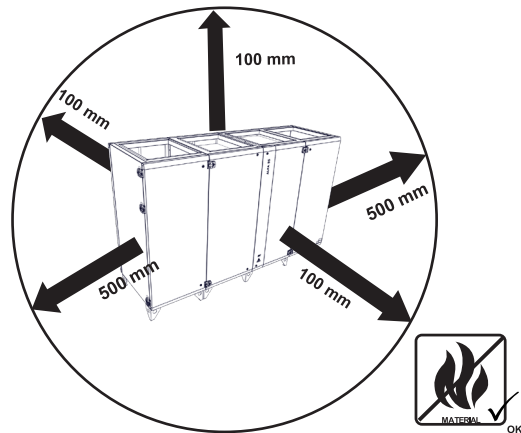

- The safe distance of flammable materials from the entry neck of the unit is 500 mm.
- The safe distance of flammable materials in the remaining directions is 100 mm.

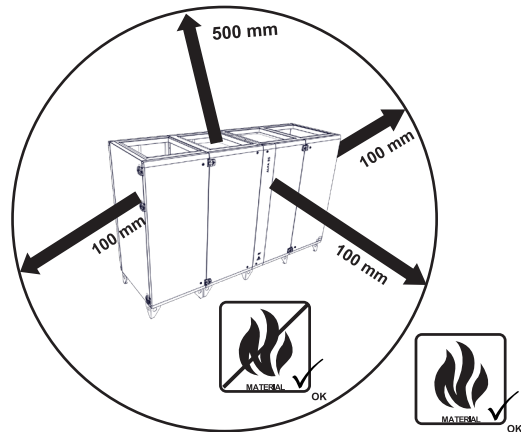

DIMENSIONS

HR953-150UP

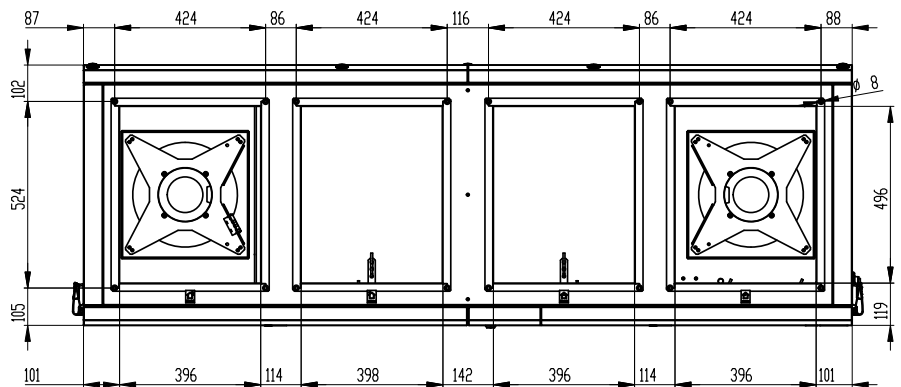
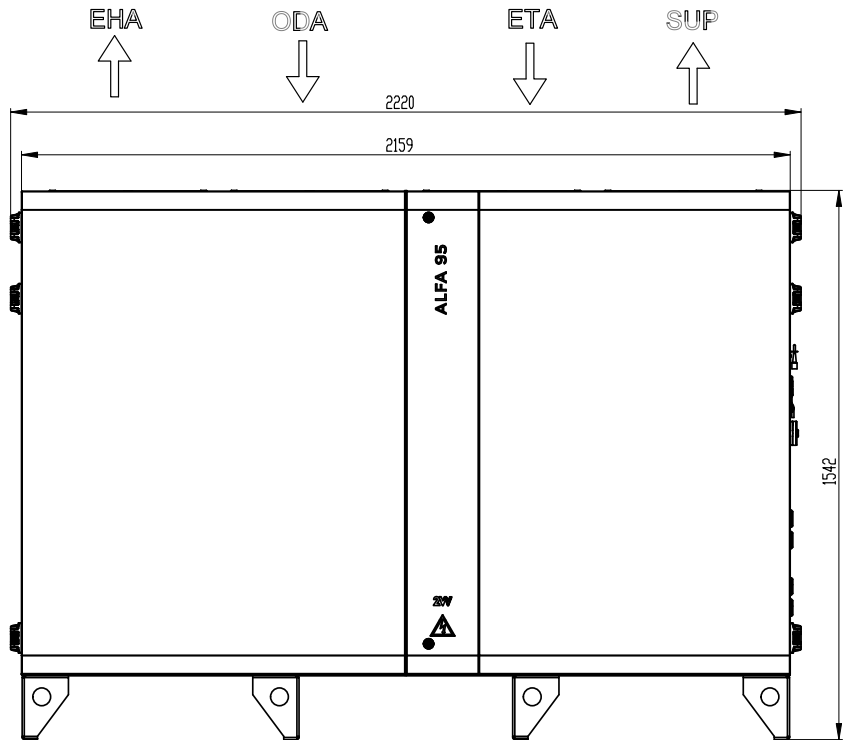
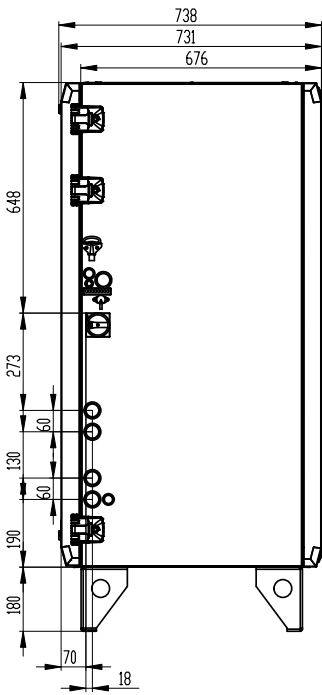
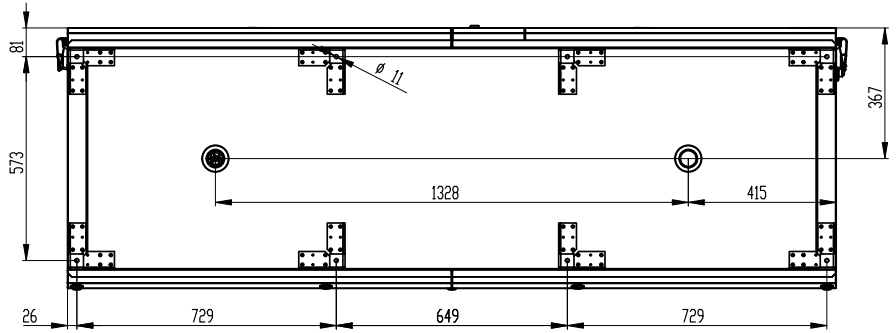

DIMENSIONS

HR953-150UL

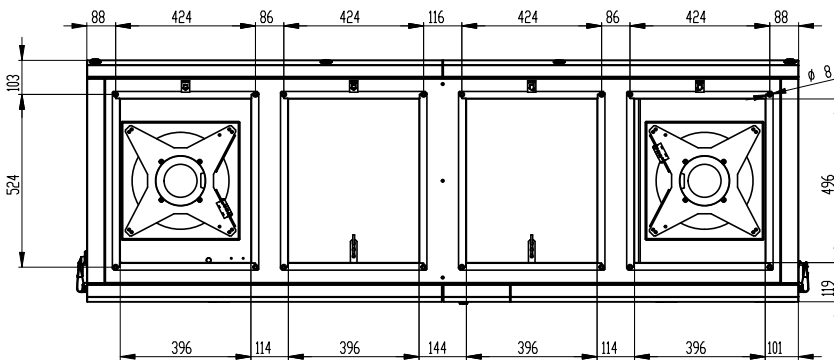
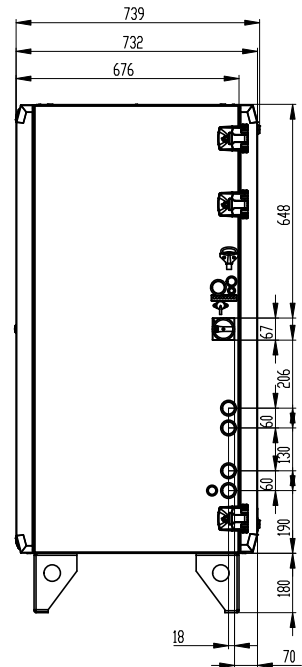
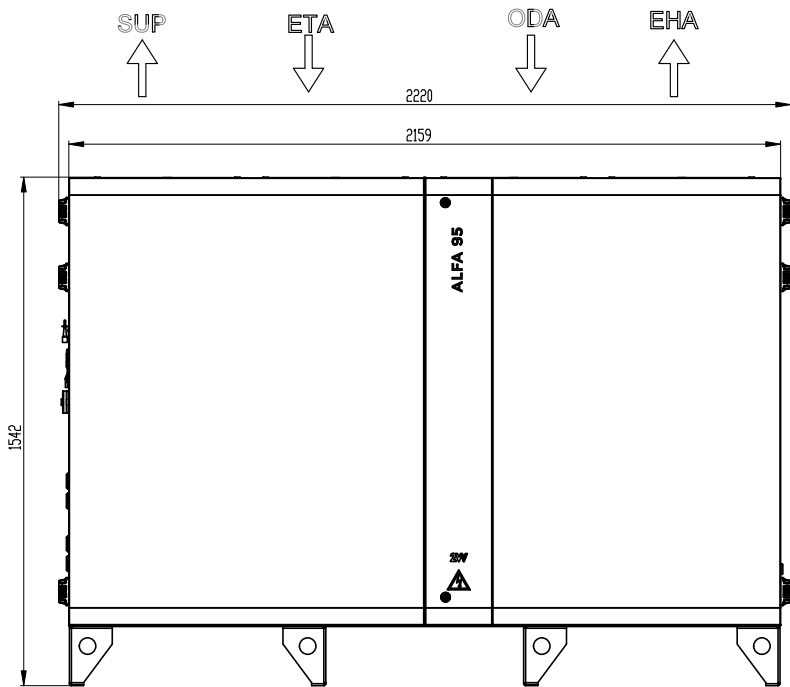
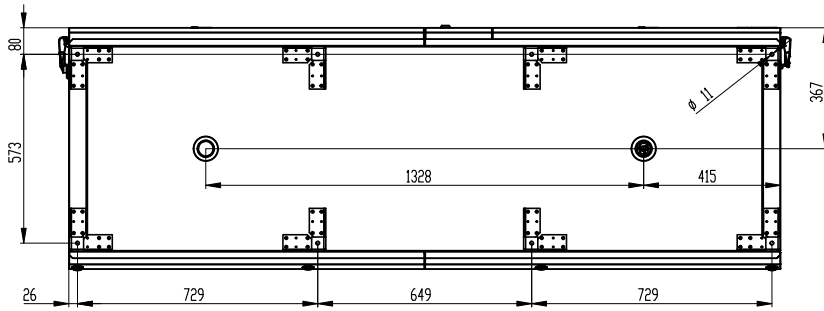

DIMENSIONS

HR953-220UP

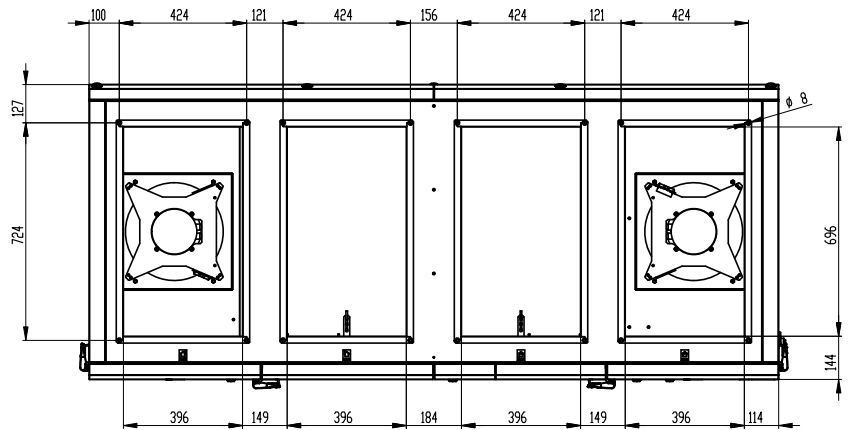
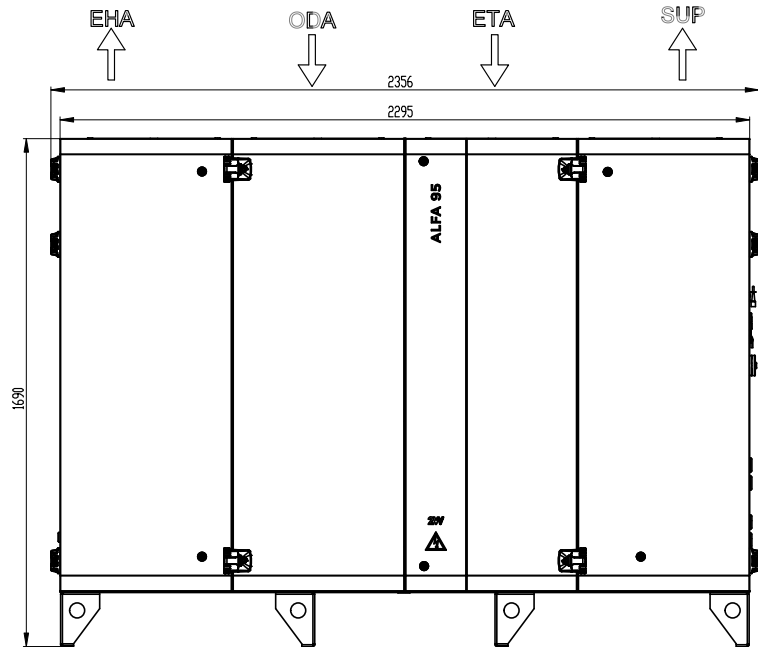
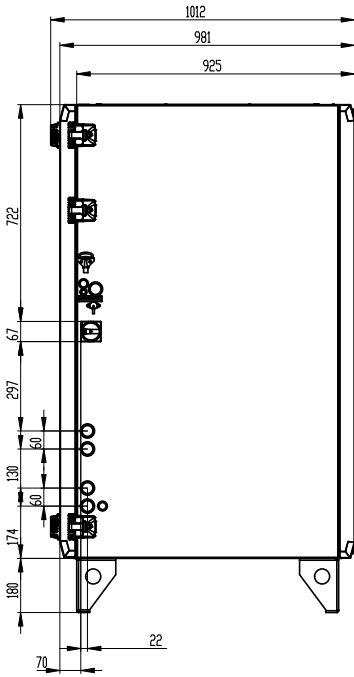
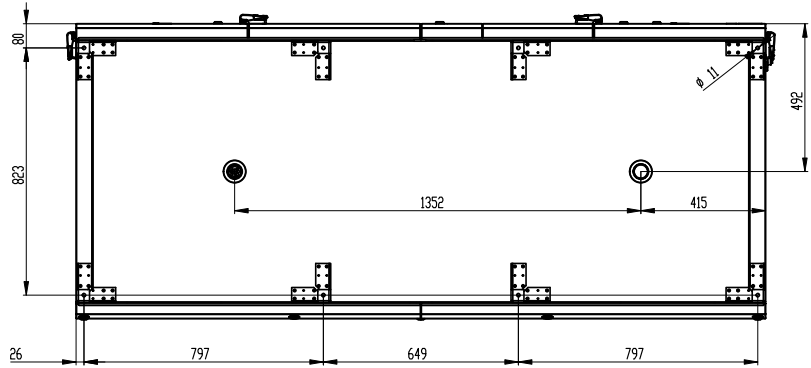

DIMENSIONS

HR953-220UL

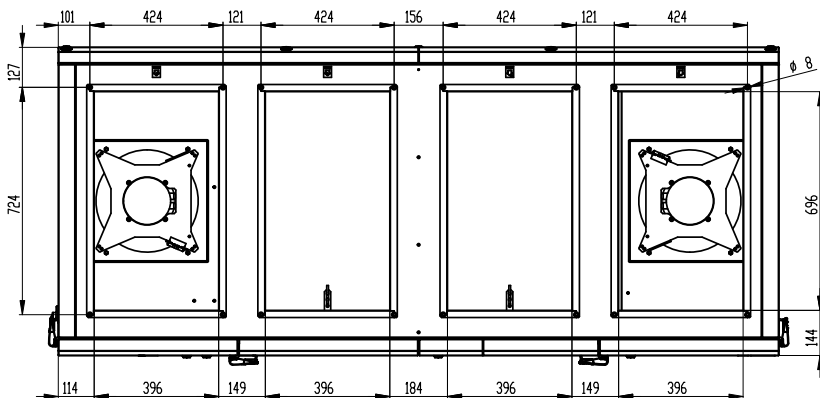
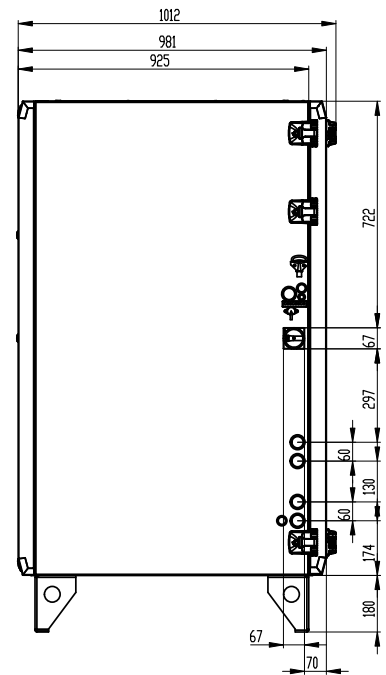
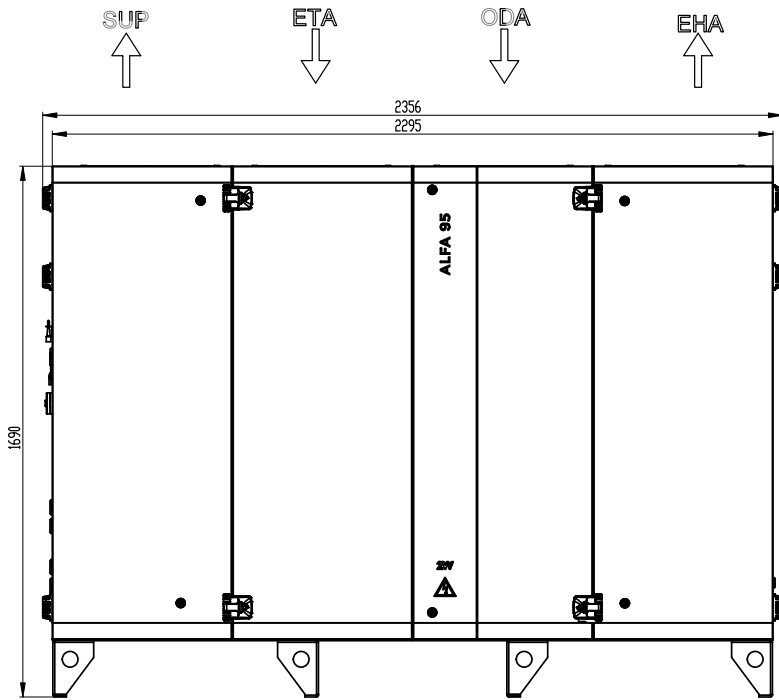
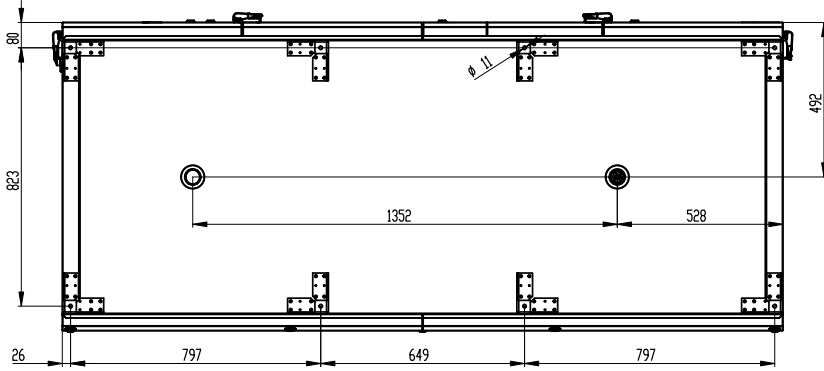

DIMENSIONS

HR953-320UP

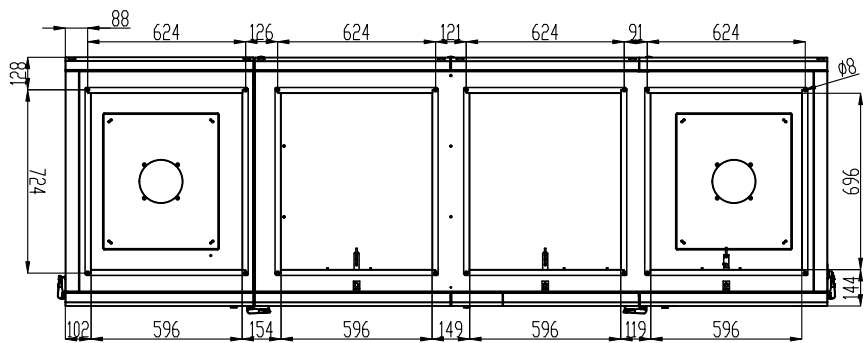
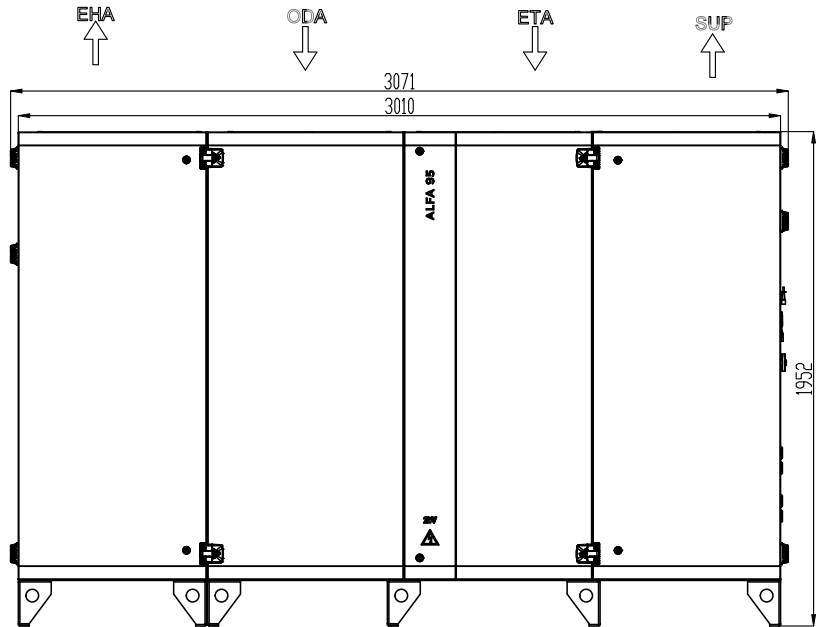
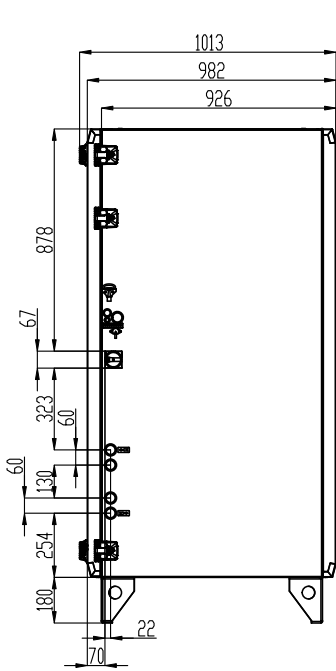
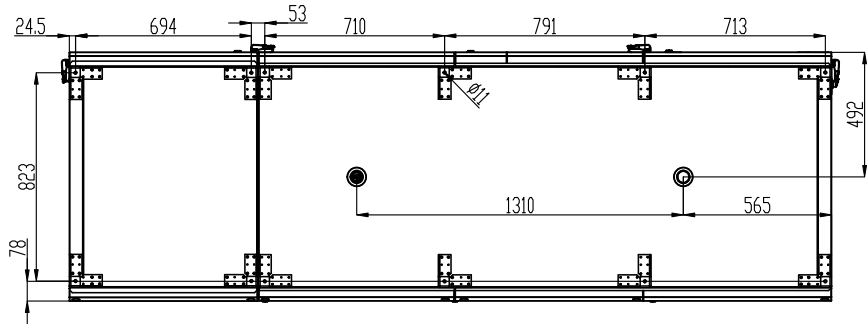

DIMENSIONS

HR953-320UL

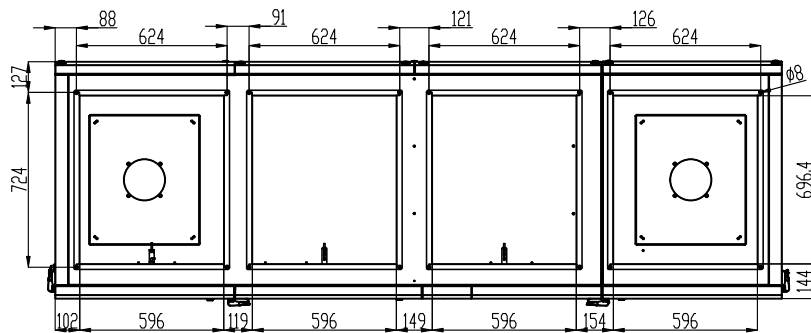
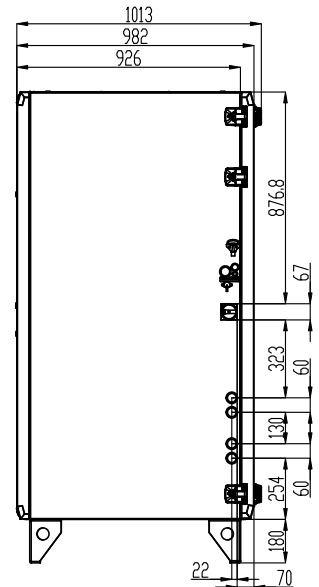
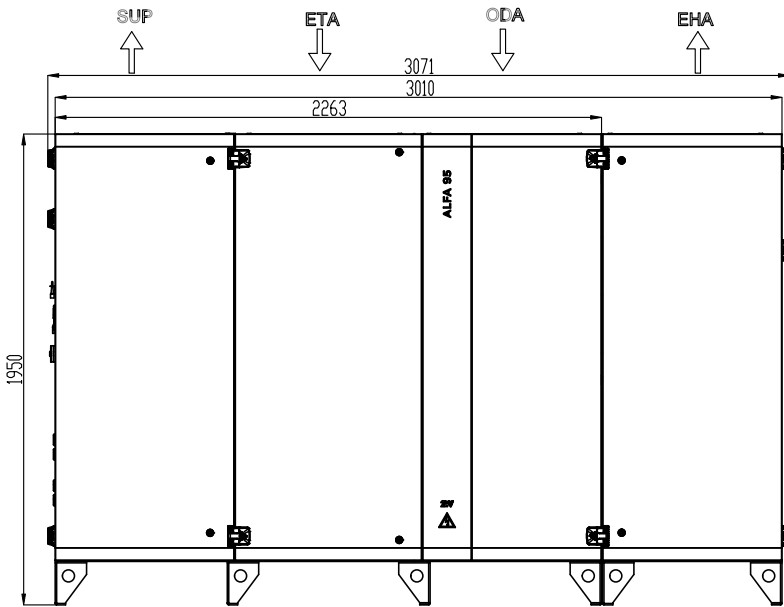
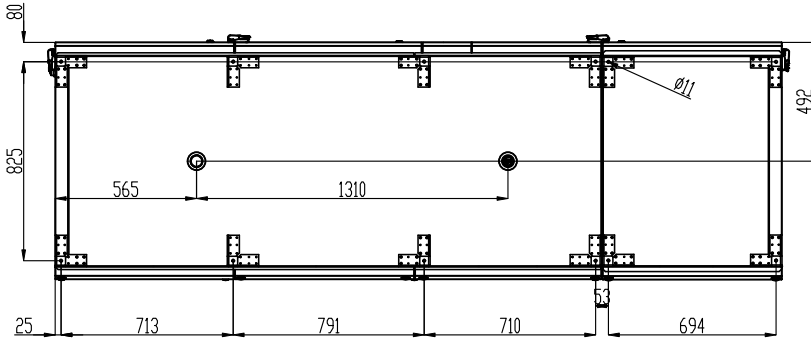

DIMENSIONS

HR953-470UP

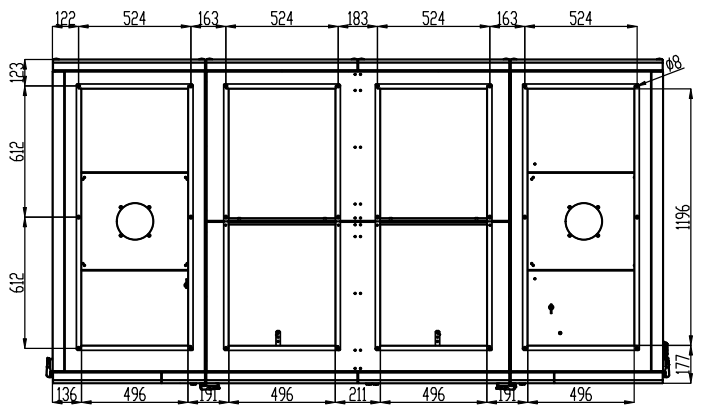
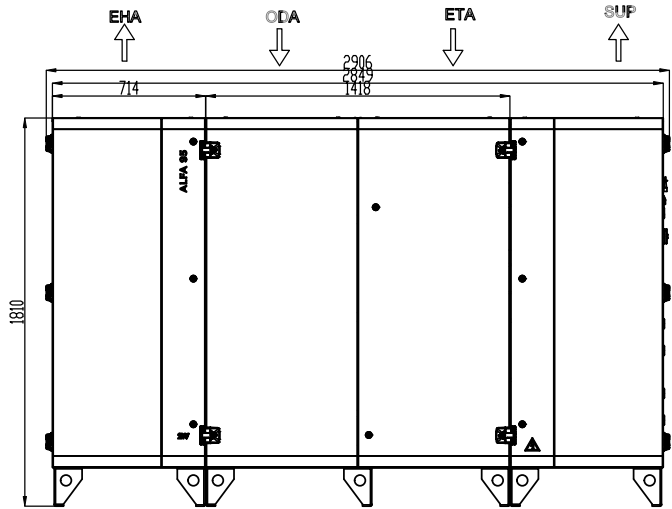
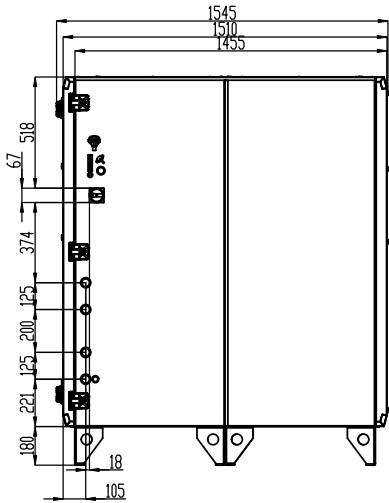
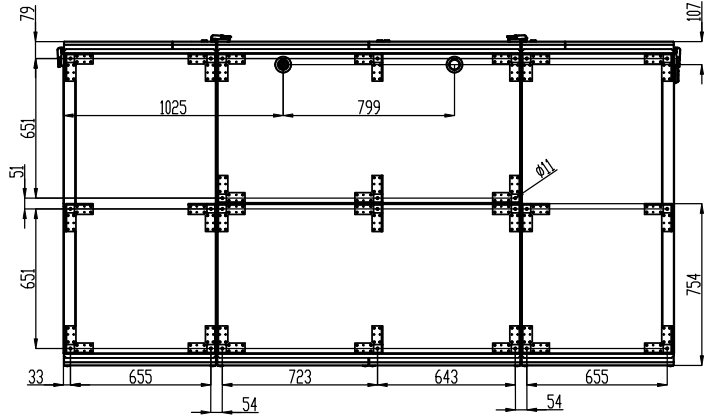

DIMENSIONS

HR953-470UL

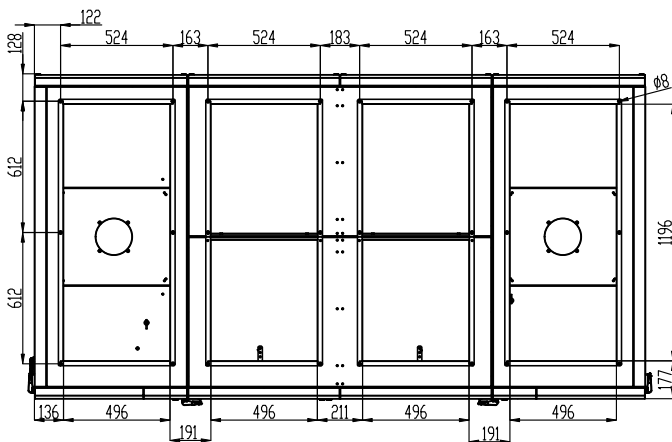
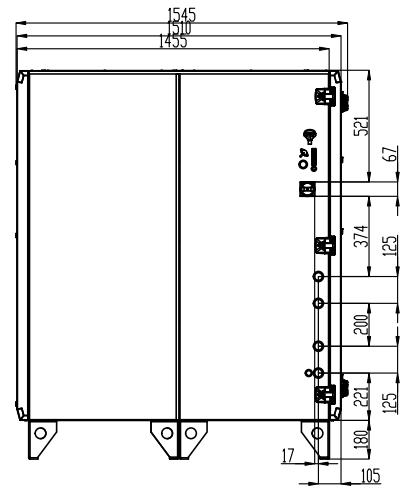
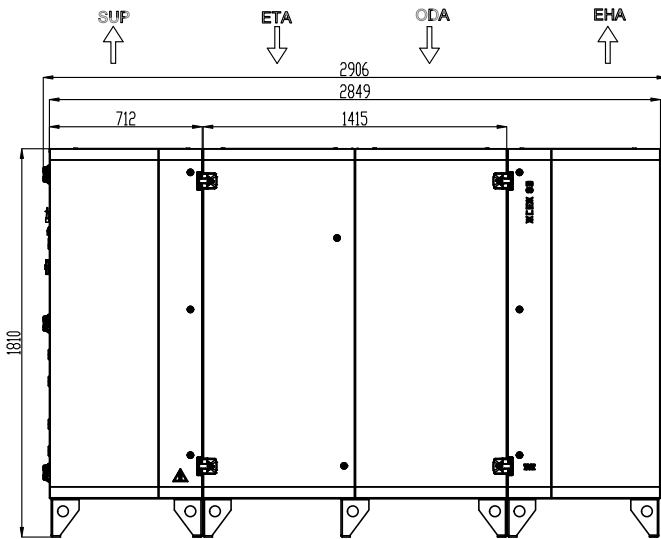
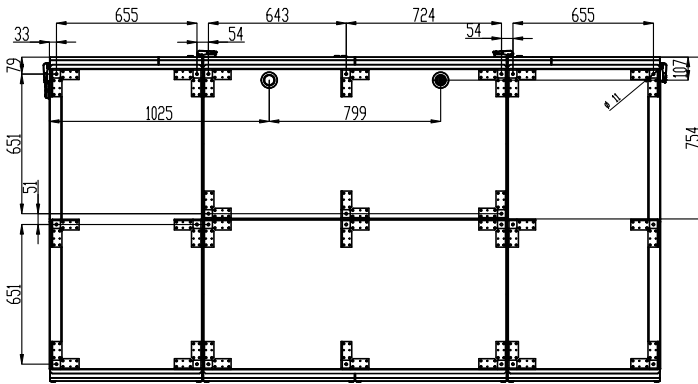

INSTALLATION



READ CAREFULLY!

- From 3200 to 4700 units are supplied as separate modules to be mounted together during installation.
- Individual modules must be attached together with bolts that are included with the unit delivery. Electrical connection of individual modules is made by universal terminals with matching numerical indication.
- Connection of pressure sensors is made in the module using tube connectors. Individual hoses must run from module to the module, which they connect in according to the numerical indication.
- It is necessary to remove all the panels including rear panels from the unit so that the modules can be assembled together.



ATTENTION!

The unit must be fixed to the base to prevent arbitrary displacement.

Given the weight of the unit, it is essential that some means of support be used to lift it (forklift or other means). The unit may only be lifted in separate modules. It is not allowed to lift the unit in one piece (sizes 3200 and 4700)

SAFE INSTALLATION DISTANCE

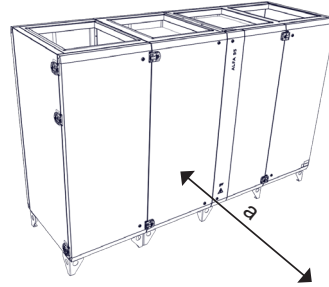

Model	a [mm]
ALFA 95 1500U	600
ALFA 95 2200U	800
ALFA 95 3200U	800
ALFA 95 4700U	1500

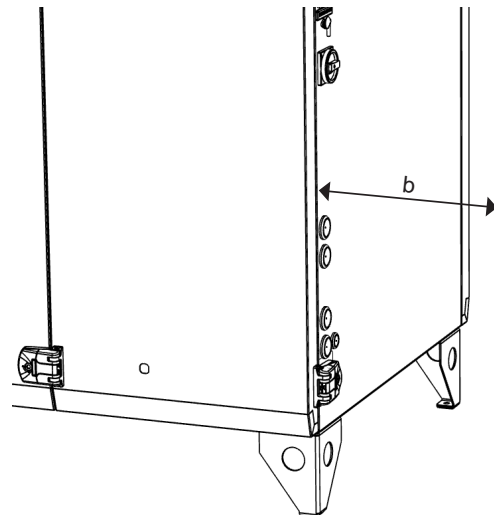

Model	b [mm]
ALFA 95 XS0S / ES0S / XE1S / EE1S	100
ALFA 95 XV1S / EV1S / XVCS / EVCS	200
ALFA 95 XD4S / ED4S	200

INSTALLATION

UNIT INSTALLATION FROM TWO SEPARATE MODULES

HR953-320U

Remove the panels from the unit and the module

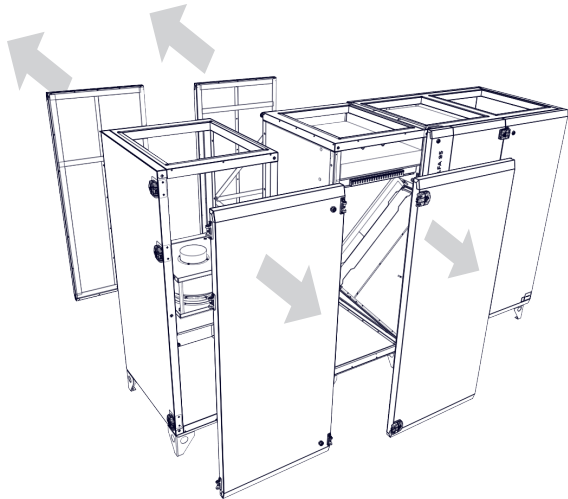

Slide the module to the unit.

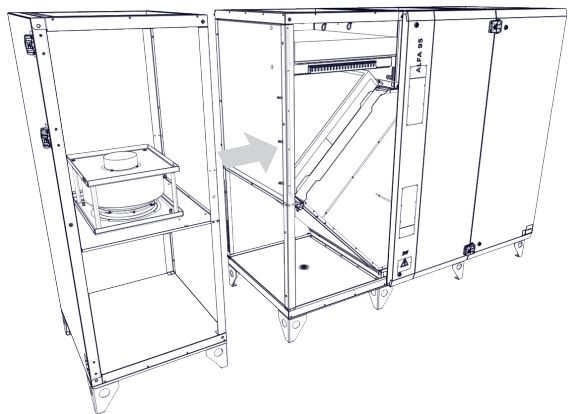

Screw the module to the unit using the screws (supplied), see figure. Connect cables and hoses.

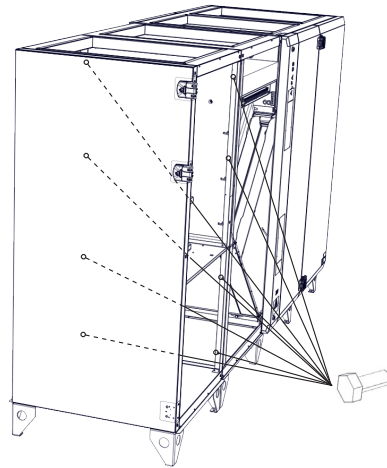

Screw the condensate tray with the rail to the central condensate tray. Make sure the rail is under the module tub not on top of it

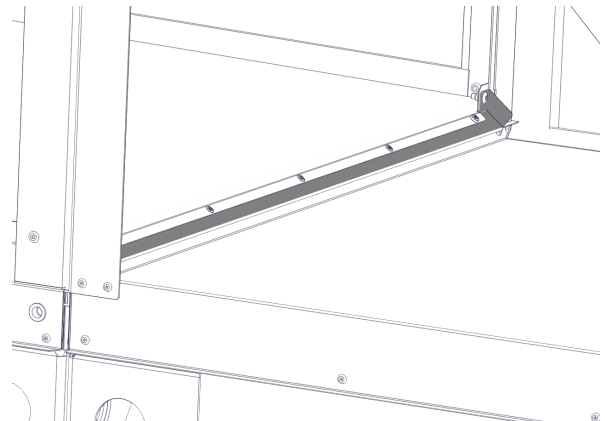

Refit the panels back onto the unit.

INSTALLATION

UNIT ASSEMBLY OF THREE SEPARATE MODULES

HR953-470U

Remove the panels from the unit and the modules

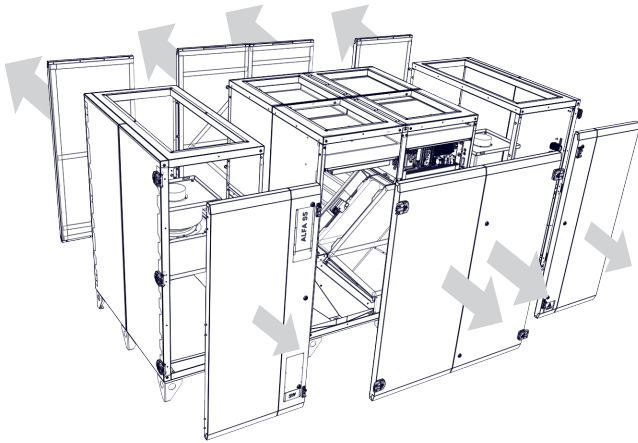

Screw the modules to the unit using the screws (supplied)

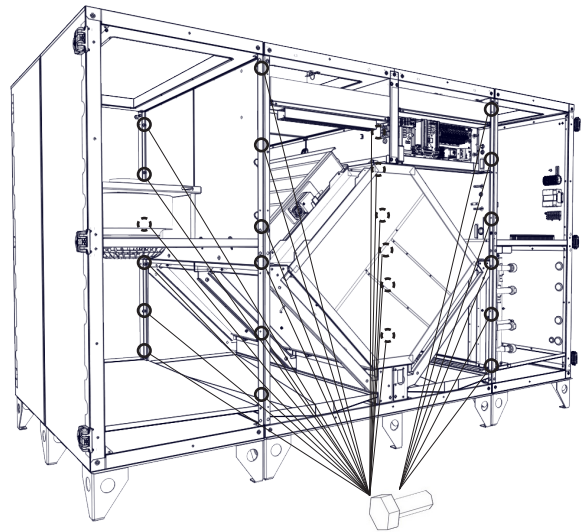

Slide the modules to the unit

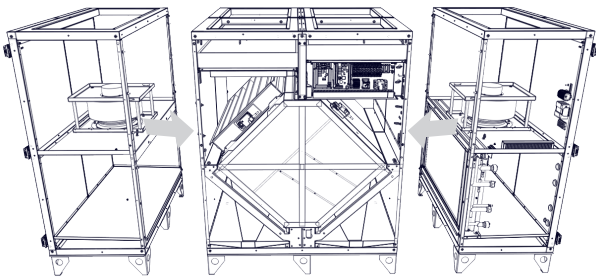

Screw the two side condensate trays to the centre condensate tray with the rail. Make sure the rail is under the module tray not on top of it

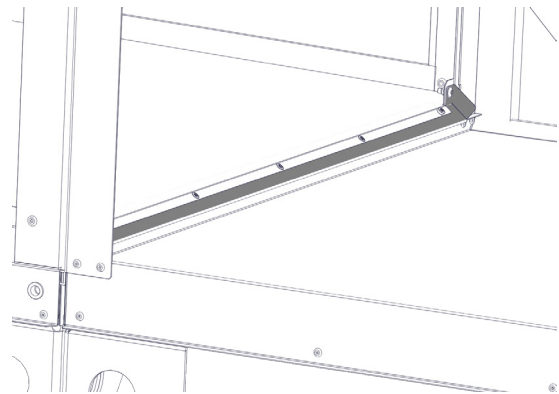

Refit the panels back onto the unit.

INSTALLATION

ELECTRICAL INSTALLATION

ATTENTION!

Before starting to repair or modify the HRV unit, make sure that the main switch is switched off!

The wiring of the HRV unit must match the layout designed by a qualified electrician. Wiring must be carried out by a person authorised to carry out electrical installation. All the following must be observed the instructions in this manual and observe local laws and regulations.

Wiring diagrams shown on the unit take precedence over the diagrams in this manual! Before connecting the wiring, make sure that the terminal markings correspond to the diagram. In the case of in doubt, do not connect the unit and contact the supplier!

The device must be connected to the mains using a thermally protected, fixed, insulated cable with a cross-sectional area corresponding to local regulations.

In order to maintain electrical protection, the all cables fit into the holes on the sides of the control unit housing.

Any changes or modifications to the internal wiring of the unit are prohibited and will result in the loss of warranty!

Correct operation of the device can only be guaranteed when using original accessories.

If it is necessary to install a sensor or control element into the unit or on its housing, consult with the manufacturer or a representative of the unit beforehand

POWER WIRING

Two sets of supply cables exit the wiring outlets for connection to the disconnect panels (preheater panel and control/fan panel) as shown in the diagrams below.

The electrical equipment must be firmly attached to the surface on which it is mounted. Each disconnecting means must be legibly marked so that its purpose is clear, unless it is located and so arranged as to make the purpose obvious. The marking shall be sufficiently durable to withstand the environment.

ATTENTION!

The minimum size of the protective earthing cable shall be in accordance with the local safety regulations relating to the power line protective earthing cable of the equipment.

TECHNICAL DATA

Please refer to the label for wiring parameters installed on the heat exchanger.

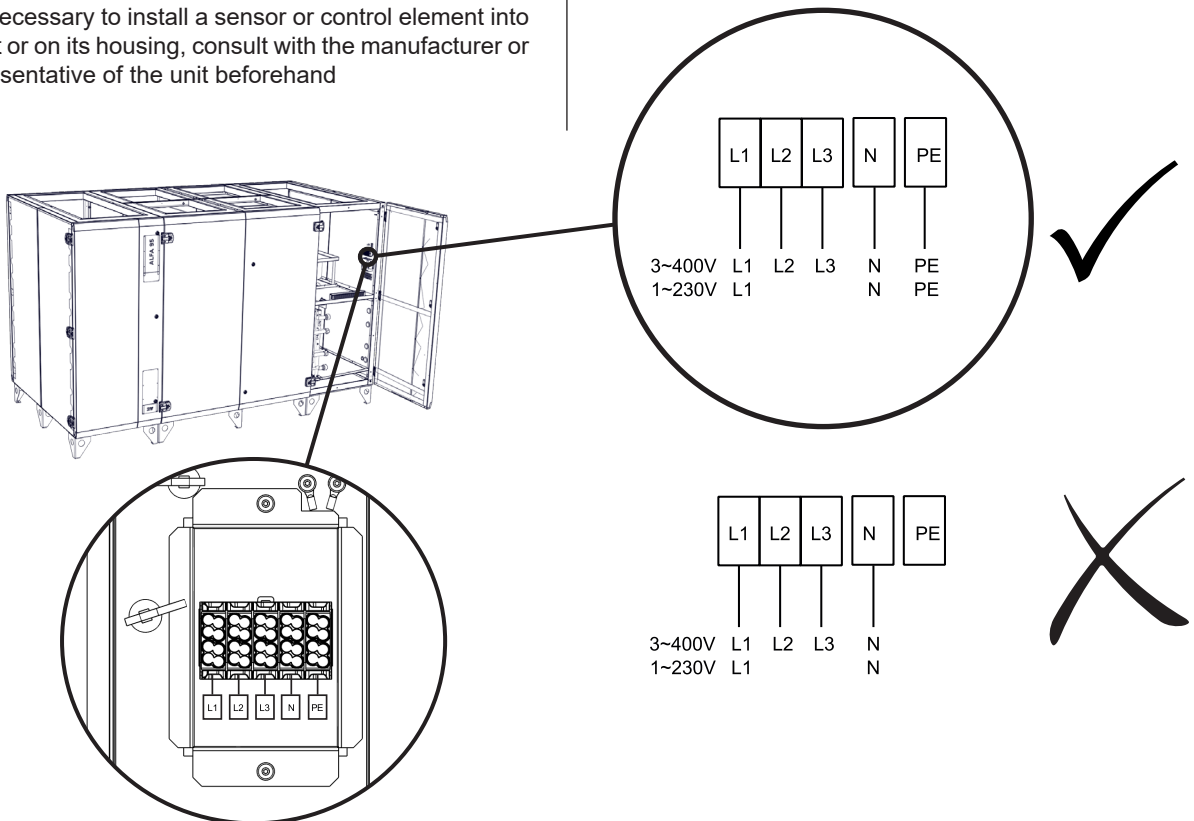

INSTALLATION

ELECTRICAL ACCESSORIES

Connect el. accessories of the unit to the terminal box located in inside the controls box according to the diagram of el. wiring and terminal indications.

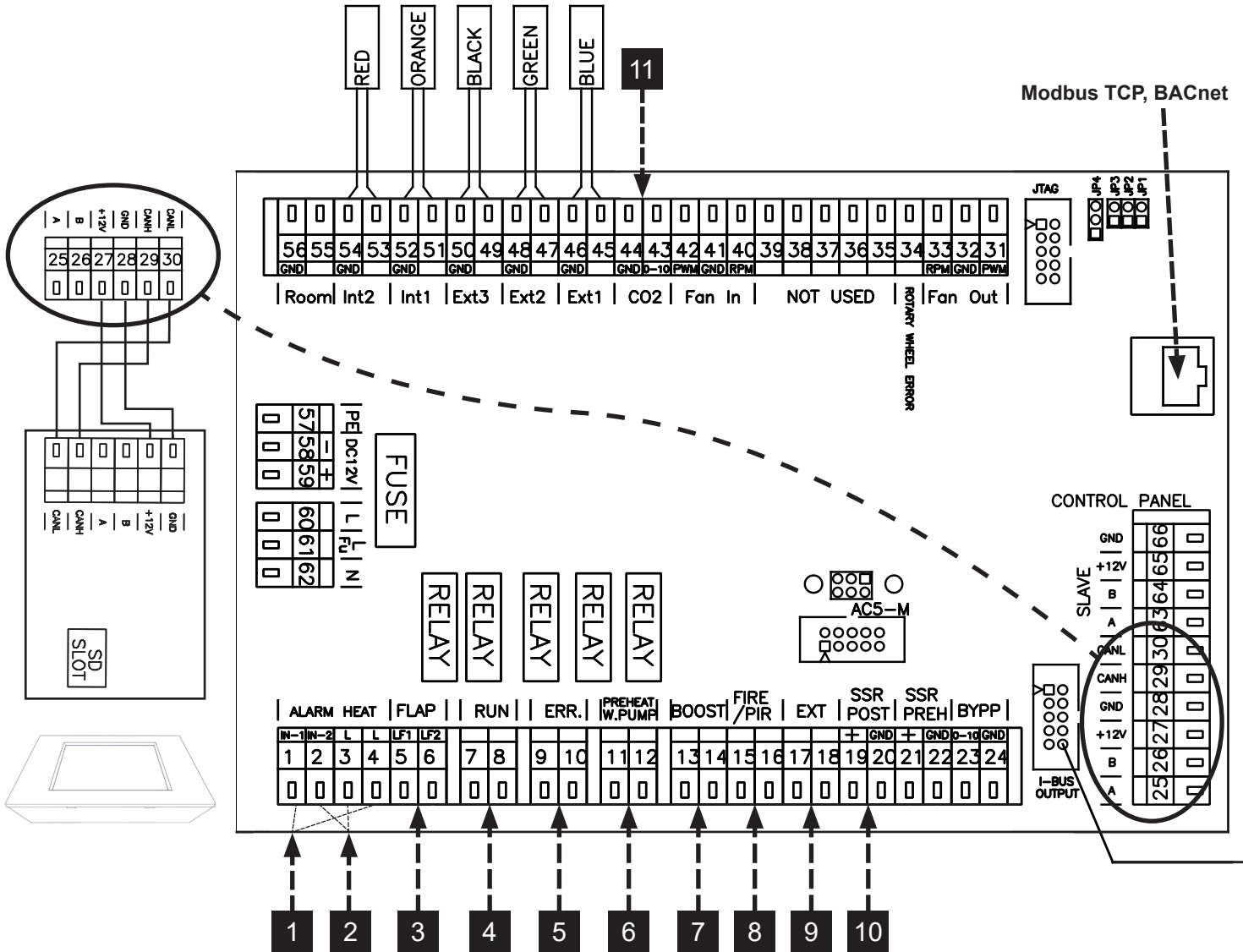

1.	A (1,4)	SAFETY THERMOSTAT POSTHEATING
2.	A (2,3)	SAFETY PREHEATING THERMOSTAT
3.	A (5-6)	LF1 - FLAP INLET (output L-open), LF2 - FLAP OUTLET (output L-open)
4.	A (7-8)	RUN CONTACT (output -NO/NC settable)
5.	A (9-10)	ERROR CONTACT (output NO)
6.	A (11-12)	PREHEATER WATER PUMP (11 - Lint, 12 - Lout)
7.	A (13-14)	BOOST (input NO)
8.	A (15-16)	FIRE (input NC)
9.	A (17-18)	EXTERNAL CONTROL ON/OFF (input NC)
10.	A (19,20)	OUTPUT PERFORMANCE OF POSTHEATING (0-10V OR PWM)
11.	A (43,44)	AQS SENSOR 0-10V (input)

INSTALLATION

Q READ CAREFULLY!

The wiring diagram is located inside the main cabinet cover (connection side) on the heat exchanger. Each accessory must be connected with the supplied cable or a cable that meets the specifications of each individual component.

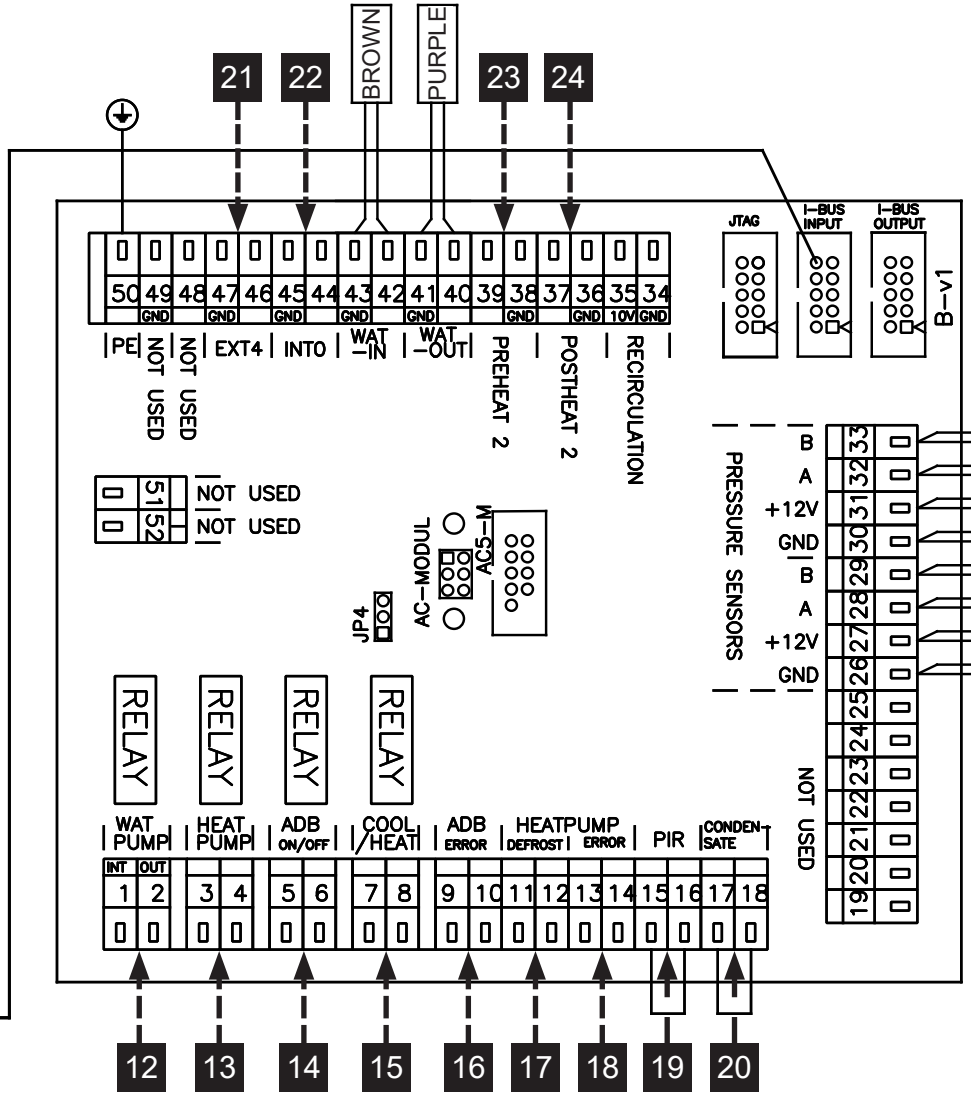

12.	B (1-2)	WATER PUMP (1 - Lint, 2 - Lout)
13.	B (3-4)	HEAT PUMP CONTROL settable (output - ON/OFF)
14.	B (5-6)	ADIABATIC MODULE (output - ON/OFF)
15.	B (7-8)	COOL / HEAT settable (CO = NC/NO - DX = output settable)
16.	B (9-10)	ADIABATIC MODULE ERROR (input NO)
17.	B (11-12)	HEAT PUMP DEFROST settable (input NC/NO)
18.	B (13-14)	HEAT PUMP ERROR settable (input NC/NO)
19.	B (15-16)	PIR (input NC)
20.	B (17-18)	CONDENSATE OVERFLOW (input NC)
21.	B (46-47)	EXTERNAL TEMPERATURE SENSOR (external postheater - input)
22.	B (44-45)	EXTERNAL TEMPERATURE SENSOR (adiabatic module / recirc. chamber - input)
23.	B (38-39)	EXTERNAL PREHEATER (output - Water= 0-10V)
24.	B (36-37)	EXTERNAL POSTHEATER (output - Water= 0-10V)

INSTALLATION

TECHNICAL DATA

BOOST BUTTON [A;13-14]

- Low-voltage switching contact: maximum possible contact load 12 V, 0.4 A.
Cable: two wires with a minimum cross-section of 0.5 mm² and a maximum length of 50 m.
- Contact is normally open. The unit is responding to the rising edge of the signal.
- The Boost button can activate but not deactivate the Boost mode.

EXTERNAL CONTROL [A;17-18]

- Low voltage switching contact - maximum possible contact load 12 V, 0.4 A.
- CABLE: cable with two leads with min. diameter 0.5 mm² Max. length 50 m.
- The contact is regularly on. When disconnected, the unit turns off.

FIRE CONTACT [A;15-16]

- Low voltage switching contact - maximum possible contact load 12 V, 0.4 A.
- CABLE: cable with two leads with min. diameter 0.5 mm² Max. length 50 m.
- The contact is regularly connected. When disconnected, the ventilation unit operates according to the preset ventilation capacity.

MOVEMENT SENSOR [B;15-16]

- Low voltage switching contact - maximum possible contact load 12 V, 0.4 A.
- CABLE: cable with two leads with min. diameter 0.5 mm² . Max. length 50 m.
- The contact is regularly disconnected. When connected, the ventilation unit operates according to the preset ventilation capacity.

ROOM SENSOR [A; 55-56]

- Low voltage input: 10k NTC thermistor
- Cable: two wires with a minimum cross section of 0.5 mm² and a maximum length of 50 m
- Use: Regulates the setting temperature of the HRV based on the ambient temperature in the room.

AIR QUALITY SENSOR [A; 55-56]

- Low voltage input: 0-10V DC
- Cable: two wires with a minimum cross section of 0.5 mm² and a maximum length of 50 m
- Any 0-10V sensor is supported. Advanced configuration is available for CO₂ , RH, VOC.

The advanced settings of these above mentioned inputs are described in the AirGENIO Superior OPERATIONAL manual.

CONTROL PANEL

To activate the unit, it is necessary to connect the remote control with the unit using a control cable (data cable)

- Slacken the bolt on the bottom of the remote control
- Open the case of the remote control
- Cut a hole for the cable
- Insert the control cable to the connector of the remote control
- Fix the control panel to the wall
- Close the control panel case

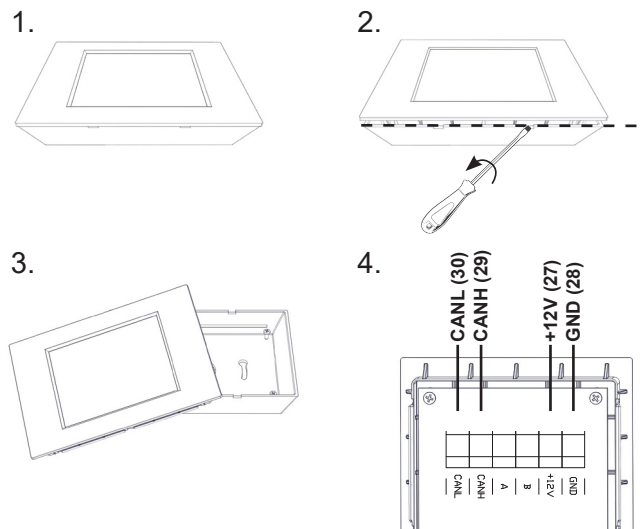

Connect the other end of the cable to the connectors of the electronic board according to the wiring diagram below.

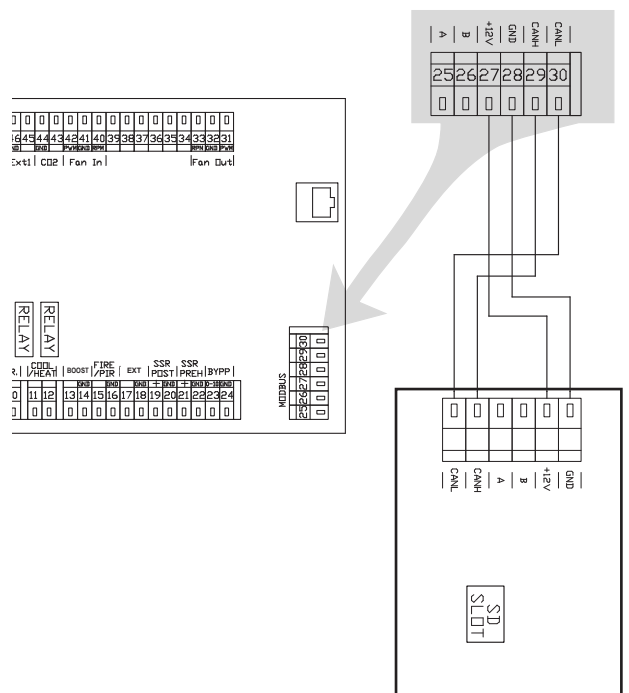

INSTALLATION

Q READ CAREFULLY!

- Maximum distance possible should be maintained between the supply cable and control cable.
- Make sure that the cable engages firmly into the connector when inserted.
- Be careful not to damage cable insulation when fixing the remote control to the wall or other surface.
- If you do not connect connectors or cables directly during unit installation, protect them against damage or short circuit using an insulating tape.
- Cable connectors must not be in contact with water or other liquid.
- Parameter settings automatically saved by battery CR2032 located on the controls PCB. This battery has a service life of 3-5 years

CONNECTING UNIT TO BMS CONTROL SYSTEM

The control system of the ventilation unit is regularly provided with RS-485 interface. To connect the control unit, use the standard communication cable. Insert the cable to one of the connectors on the electronic board of the ventilation unit. Connect the other end to the main control unit. For details of the protocol (ModBUS) see 2VV.

A controller may also be connected to the unit connected to the a BMS control system

CONNECTING CONDENSATE DRAIN

Condensate discharge from the external module must be connected to the discharge piping by air trap.

W YOU WILL NEED

- 1 air trap (part of elivery)
- PVC discharge pipe
- discharge pipe sealing

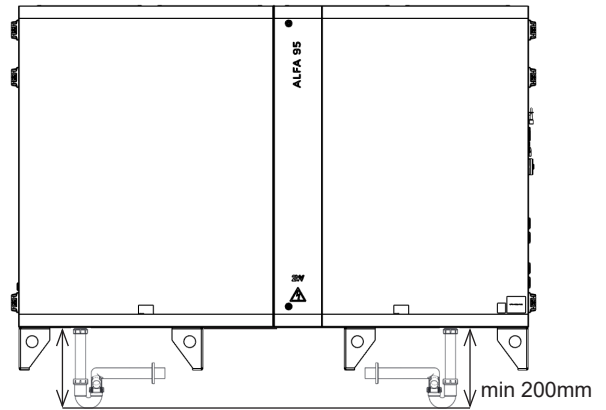

! ATTENTION!

Before putting the unit into operation, fill in the trap with water!!! Otherwise there is a risk of flooding and damage to the unit.

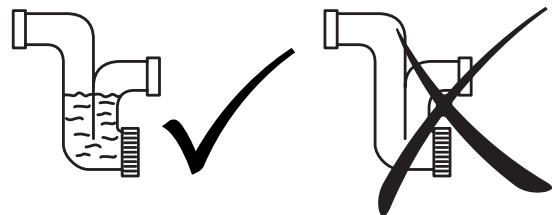

INSTALLATION

3-050-D37339

Unit with pre-heater and no post heater / water postheater / DX or VC coil

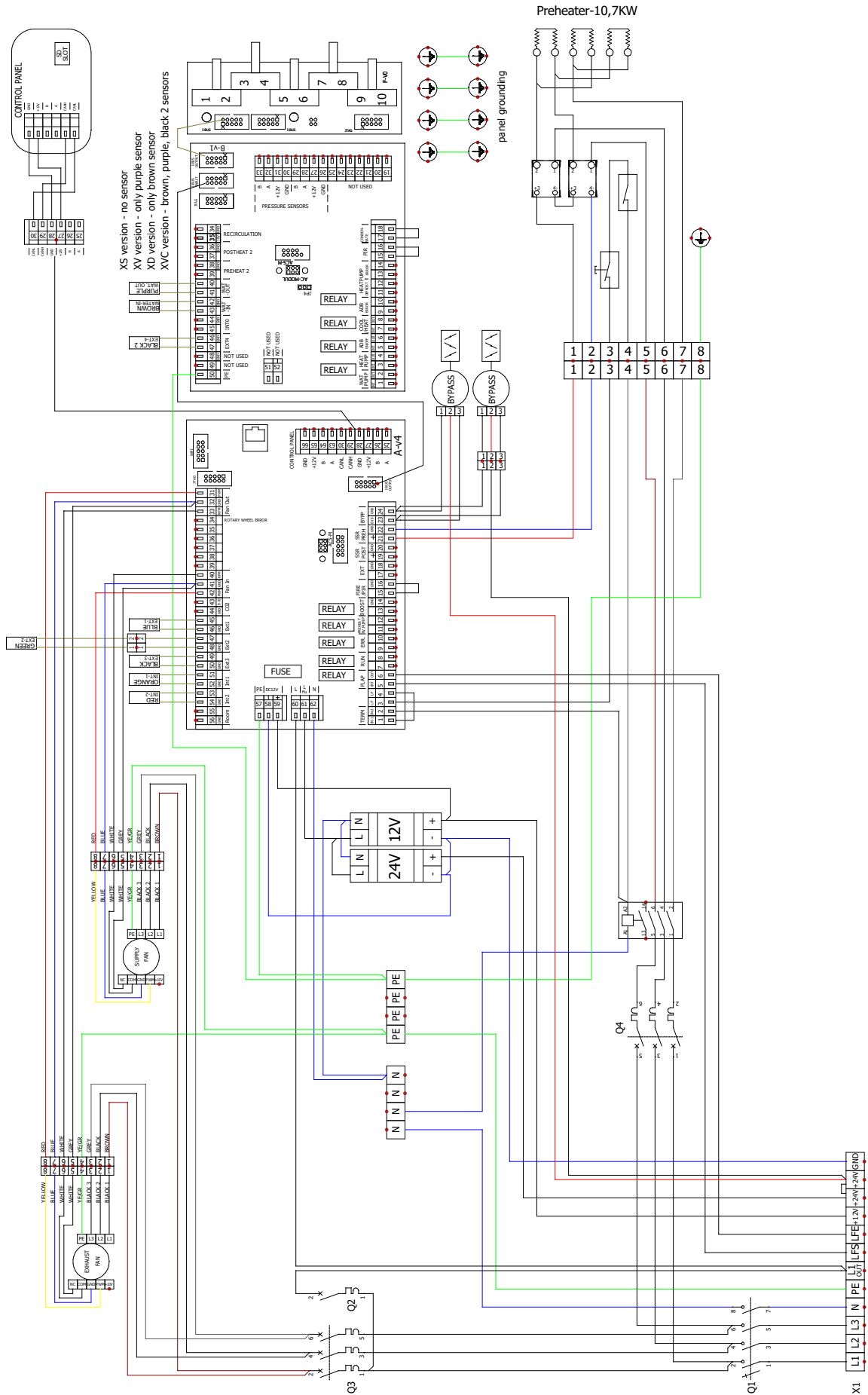

HR953-320UX-ES0S/EV1S/ED3S/EVCS-xxx

X1 MAIN SUPPLY + CUSTOMER ACCESSORY
 Q1 MAIN SWITCH
 Q2-Q4 CIRCUIT BREAKER

INSTALLATION

3-050-D37342

Unit with pre-heater and electric postheater

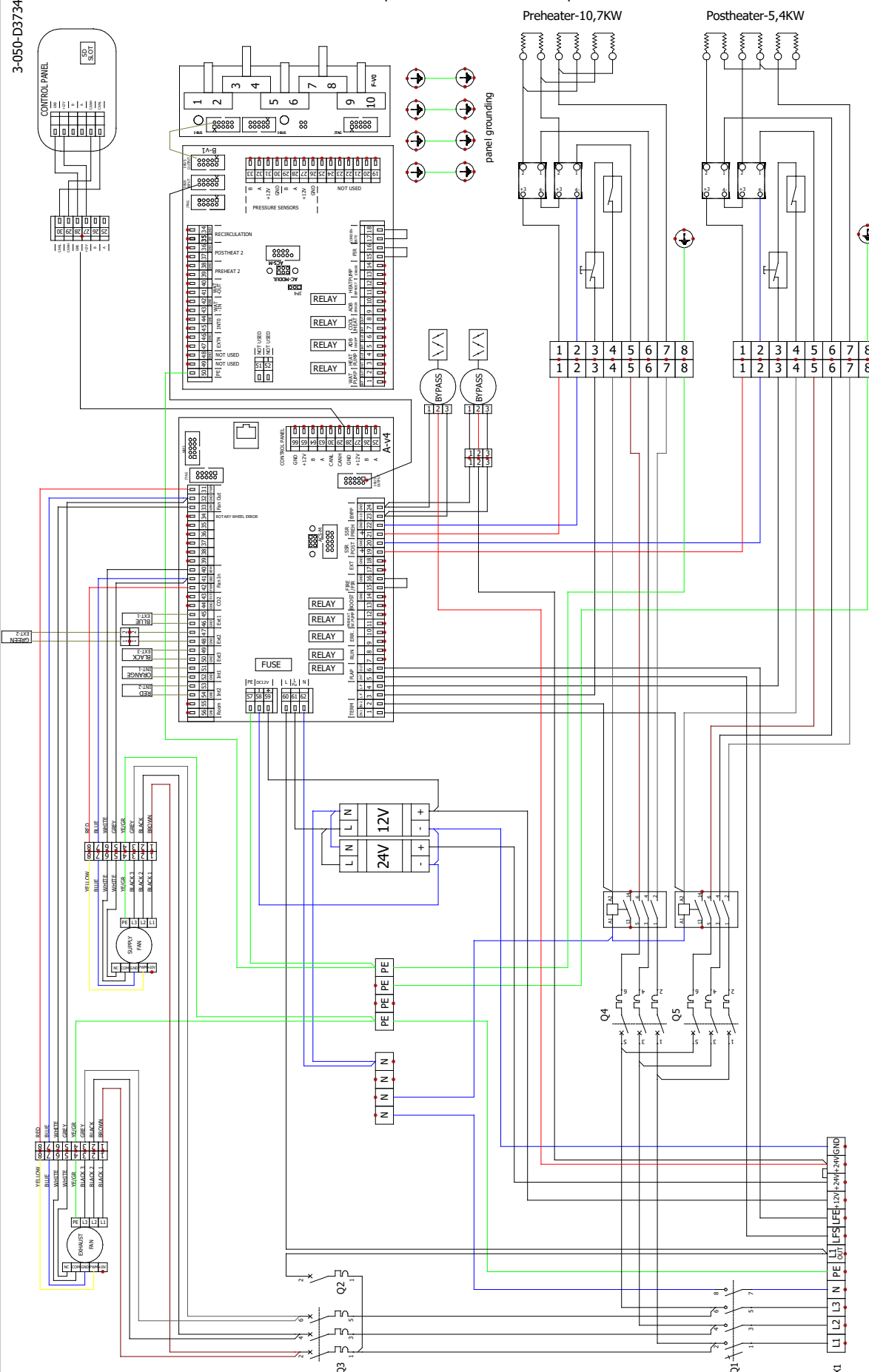

HR953-320UxEX-EEIS-xxx

- X1 MAIN SUPPLY + CUSTOMER ACCESSORY
- Q1 MAIN SWITCH
- Q2-Q5 CIRCUIT BREAKER

READ CAREFULLY!

Please check the following before first operation:

- That the unit is mounted well to the support structure.
- That the unit is closed correctly, and that ducts are properly connected, rain-protection roof installed, and that duct connections or other components are not in contact with any rotating or heating components
- That the electrical wiring is connected correctly, including grounding and protection against external activation.
- That all accessories are connected correctly.
- That the condensate drain is connected correctly to the discharge piping (for units with cooling).
- That the connection is in compliance with instructions in this manual.
- That no tool or other object has been left inside the unit, which could result in damage to the unit.

ATTENTION!

- Any interventions or modifications to unit wiring are prohibited and may lead to warranty loss!
- We recommend using 2VV approved accessories only.

ACTIVATION

To activate the unit (Stand by mode), it is necessary to turn the main switch on (ON= red OFF= green). After activation, the display on the control panel lights up and data download will start. After complete download of these data, the unit is ready for operation.

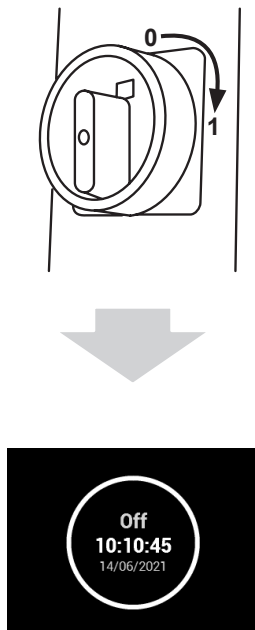

MAINTENANCE

ATTENTION!

It is recommended to perform a visual inspection of the filter at least once every 3 months. If the user interface panel indicates a clogged filter alarm, replace all filters immediately.

REPLACING FILTERS

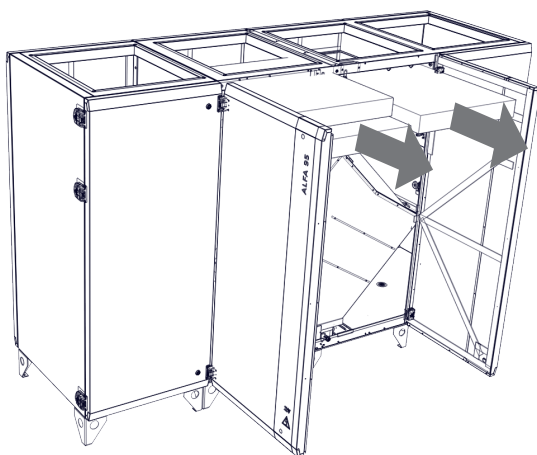
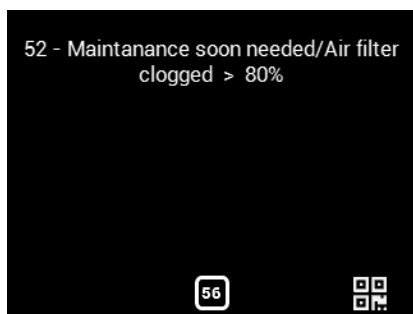
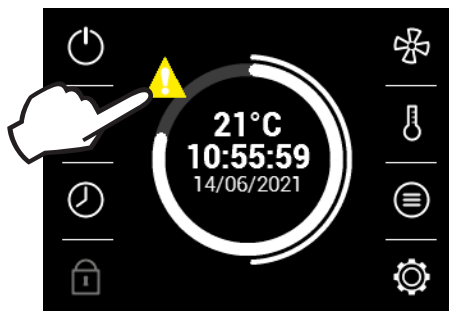

YOU WILL NEED

- 1) Open the cover
- 2) Remove the air filter
- 3) Replace the air filter according to the unit type

READ CAREFULLY!

- Warning icon of filter replacement disappears automatically

ATTENTION!

Device functionality might be reduced or impaired, if the filter is not duly cleaned or replaced.

CLEANING INTERVALS OF THE VENTILATION UNIT

YOU WILL NEED

- 6mm Allen wrench
- vacuum cleaner
- brush
- rag
- neutral cleaning agent (soap water)

We suggest checking and cleaning the unit every six months; however these intervals must be accommodated to specific operating conditions. We suggest thorough cleaning of the unit once a year. If the unit is not in use for a long time, we suggest its activation every six months for about an hour.

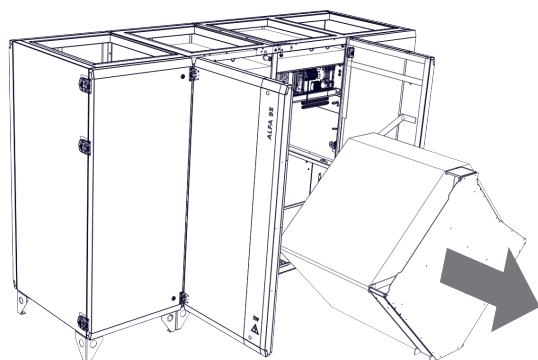

Clean the unit with a vacuum cleaner, brush, cloth and soapy water.

To clean the heat exchanger, pull it into the halfway backwards with a nylon tightening strap. Vacuum and wash the rear part. Then pull the heat exchanger halfway out towards the front and vacuum and wash.

Do not use sharp objects, harsh chemicals, solvents, abrasive cleaners, high-pressure cleaners, compressed air, or steam.

⚠ ATTENTION!

In case of power failure and subsequent recovery of the mains power supply, the unit returns to the state before such failure.

The unit always remembers the operating status and all setups. If you fail to find or remove the cause of the fault, or if the repair requires intervention in the device, contact the authorised service

ELECTRIC HEATING OVERHEAT

If the electric heating overheats, the safety thermostat is disconnected. Upon removing the cause of such overheat, it is necessary to reset manually the safety thermostat located directly on the electric heater.

Location of the safety thermostat is indicated with  RESET mark in each unit

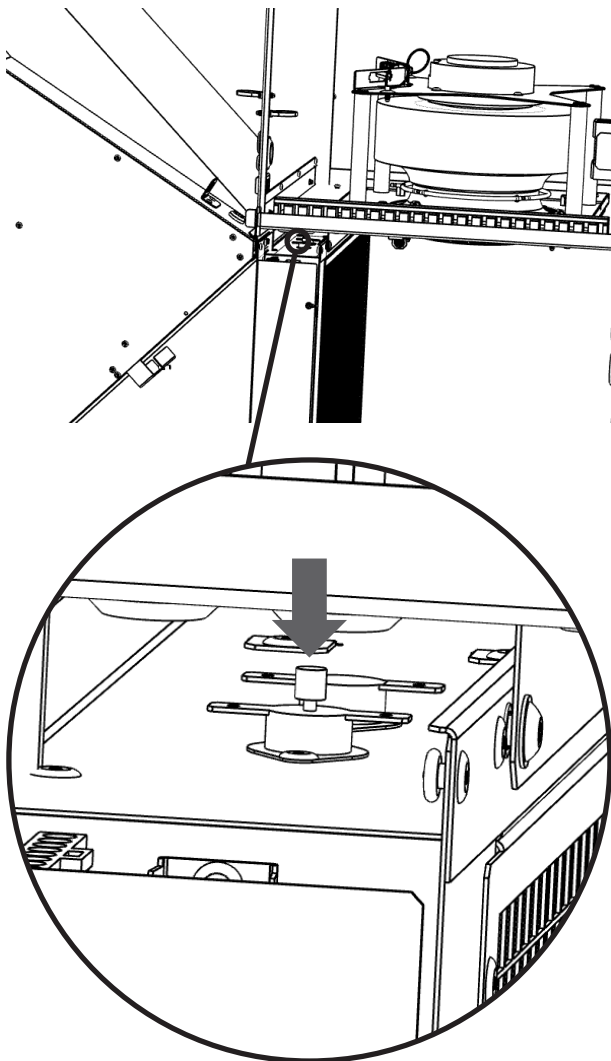

Push in the way of arrow in the picture above to reset the thermostat.



ATTENTION!

Before starting maintenance and repairs, the unit must be disconnected from the power supply, the supply voltage must be blocked and the service switches must be in position 0 (OFF)!

Do not attempt a repair unless you are familiar with the exact procedure. Contact a qualified service centre.



TECHNICAL DATA

Usually indicated error messages on the display.
See table below.

DESCRIPTION	UNIT STATUS	LIKELY PROBLEM	SOLUTION
1 - Request for filter calibration	Unit is working	after resetting the unit, or while recording the control	after inserting new filters enter menu 1616 on line 05 and calibrate the filters
4 – Supply fan error	Unit is not working	Overheated fan or defect on thermal contact of inlet fan	Determine the cause of the overheating (defective bearing, short-circuit...) or replace the engine.
5 – Exhaust fan error	Unit is not working	Overheated fan or defect on thermal contact of inlet fan	Determine the cause of the overheating (defective bearing, short-circuit...) or replace the engine.
6 – Inlet filter clogged	Unit is working	Clogged filter	Check the condition of the filter, or replace it. If the unit does not have a pressure sensor for the filter, RESET the clogged filter according to the manual.
7 – Exhaust filter clogged	Unit is working	Clogged filter	Check the condition of the filter, or replace it. If the unit does not have a pressure sensor for the filter, RESET the clogged filter according to the manual.
8 - Failure in preheating 1	Unit is working	Overheated electric exchanger or damaged sensor Open the exchanger thermostat.	Check that air can flow freely through the unit, electric heat exchanger is not cooling sufficiently. Check the safety thermostat on the electric preheating for damages.
9 - Failure in exchanger 1	Unit is working	Overheated electric exchanger or damaged sensor Open the exchanger thermostat.	Check that air can flow freely through the unit, electric heat exchanger is not cooling sufficiently. Check the safety thermostat on the electric reheating for damages.
10 - Failure in exchanger 2	Unit is working	Overheated electric exchanger or damaged sensor Open the exchanger thermostat.	Check that air can flow freely through the unit, electric heat exchanger is not cooling sufficiently. Check the safety thermostat on the electric reheating for damages.
11 - Failure in preheating 1	Unit is working	Overheated electric exchanger or damaged sensor Open the exchanger thermostat.	Check that air can flow freely through the unit, electric heat exchanger is not cooling sufficiently. Check the safety thermostat on the electric preheating for damages.
12 – CO2 sensor failure	Unit is working	Defective air quality sensor	Check that the CO2 sensor is connected correctly or check that it is operating correctly (output signal value)
13 - Failure of rotary heat exchanger	Unit is not working	Failure of rotary heat exchanger	Check that the input error is correctly connected to the electronics or check what type of error the heat exchanger is indicating.

DESCRIPTION	UNIT STATUS	LIKELY PROBLEM	SOLUTION
14 - ADB module error	Unit is working	Failure of adiabatic module	Check that the input error is correctly connected to the electronics or, if necessary, that the adiabatic module is operating correctly
15 - Heat pump error	Unit is working	Heat pump failure	Check that the input error is correctly connected to the electronics or, if necessary, that the heat pump is operating correctly (according to the instructions of its manufacturer)
16 – Inlet – External temperature sensor failure (T-EXT1)	Unit is not working	Room temperature sensor failure	Check that the sensor is correctly connected to the electronics or test it measuring its resistance (the resistance value at +20°C is around 10kW)
17 – Inlet – Failure of the temperature sensor behind the exchanger (T-EXT2)	Unit is not working	Room temperature sensor failure	Check that the sensor is correctly connected to the electronics or test it measuring its resistance (the resistance value at +20°C is around 10kW)
18 – Inlet – Temperature sensor failure in the supply canal (T-EXT3)	Unit is not working	Room temperature sensor failure	Check that the sensor is correctly connected to the electronics or test it measuring its resistance (the resistance value at +20°C is around 10kW)
19 - Inlet - Temperature sensor failure after the second exchanger (T-EXT4)	Unit is not working	Room temperature sensor failure	Check that the sensor is correctly connected to the electronics or test it measuring its resistance (the resistance value at +20°C is around 10kW)
20 - Exhaust - Temperature sensor failure in the exhaust canal (T-INT0)	Unit is not working	Room temperature sensor failure	Check that the sensor is correctly connected to the electronics or test it measuring its resistance (the resistance value at +20°C is around 10kW)
21 - Exhaust - Temperature sensor failure in the exhaust canal (T-INT1)	Unit is not working	Room temperature sensor failure	Check that the sensor is correctly connected to the electronics or test it measuring its resistance (the resistance value at +20°C is around 10kW)
22 – Exhaust – Failure of the temperature sensor of the exchanger's anti-freeze protection (T-INT2)	Unit is not working	Room temperature sensor failure	Check that the sensor is correctly connected to the electronics or test it measuring its resistance (the resistance value at +20°C is around 10kW)
23 - Temperature sensor failure of the exchanger's water supply (T_WATER_IN)	Unit is not working	Room temperature sensor failure	Check that the sensor is correctly connected to the electronics or test it measuring its resistance (the resistance value at +20°C is around 10kW)
24 - Failure in the return water sensor of exchanger (T_WATER_OUT)	Unit is not working	Room temperature sensor failure	Check that the sensor is correctly connected to the electronics or test it measuring its resistance (the resistance value at +20°C is around 10kW)

FAULTS REMOVAL

DESCRIPTION	UNIT STATUS	LIKELY PROBLEM	SOLUTION
25 – Room temperature sensor failure (T_Room)	Unit is working	Room temperature sensor failure	Check that the sensor is correctly connected to the electronics or test it measuring its resistance (the resistance value at +20°C is around 10kΩ)
26 - Failure in the pressure sensor of the exhaust filter	Unit is working	Pressure sensor failure	Check the supply point for mechanical damage or whether it is clogged by dirt, or whether the supply hoses are free. The pressure sensor will likely need to be replaced
27 - Failure in the pressure sensor of the inlet filter	Unit is working	Pressure sensor failure	Check the supply point for mechanical damage or whether it is clogged by dirt, or whether the supply hoses are free. The pressure sensor will likely need to be replaced
28 - Failure in the pressure sensor of the inlet fan	Unit is not working correctly	Pressure sensor failure	Check the supply point for mechanical damage or whether it is clogged by dirt, or whether the supply hoses are free. The pressure sensor will likely need to be replaced
29 - Failure in the pressure sensor of the exhaust fan	Unit is not working correctly	Pressure sensor failure	Check the supply point for mechanical damage or whether it is clogged by dirt, or whether the supply hoses are free. The pressure sensor will likely need to be replaced
30 - Failure in the pressure sensor of the VAV supply channel	Unit is not working correctly	Pressure sensor failure	Check the supply point for mechanical damage or whether it is clogged by dirt, or whether the supply hoses are free. The pressure sensor will likely need to be replaced
31 - Failure in the pressure sensor of the VAV C4 exhaust channel	Unit is not working correctly	Pressure sensor failure	Check the supply point for mechanical damage or whether it is clogged by dirt, or whether the supply hoses are free. The pressure sensor will likely need to be replaced
32 - Air quality sensor failure	Unit is working	Defective air quality sensor	Check that the quality sensor is connected correctly or check that it is operating correctly (output signal value)
33 - Failure in the recirculation relative humidity sensor	Unit is working	Defective relative humidity sensor	Check that the humidity sensor is connected correctly or check that it is operating correctly (output signal value)
34 - Failure in the sensor of external temperature from BMS	Unit is working	Defective sensor in BMS or incorrectly received data	Check that the address and values of the sensor in the BMS system are correct. Check that the sensor in the BMS system is working.
35 - Failure in the REK antifreeze protection relative humidity sensor	The unit is ventilating the permission to use preheating	Defective relative humidity sensor	The communication cable to the relative humidity sensor is damaged or disconnected. The humidity has exceeded the permitted limit and the sensor may temporarily measure incorrect values. Check the connection of the sensor. Set its address Check that it is not flooded. Replace if necessary.

FAULTS REMOVAL

DESCRIPTION	UNIT STATUS	LIKELY PROBLEM	SOLUTION
50 - Inlet filter clogged > 80%	Unit is working	Clogged filter	Filter change recommended
51 - Exhaust filter clogged > 80%	Unit is ventilating	Clogged filter	Filter change recommended
70 - Anti-freeze protection of the water heat exchanger	Unit is ventilating	The anti-freeze protection of the water heat exchanger is active	The automatic protection of the water exchanger has been activated in order to prevent damages due to low air temperature. This is an autonomous function and will be terminated once the risk of frost disappears. f
71 - Water heater - waiting for water temperature	Unit is ventilating	The unit controls the temperature of the liquid in the exchanger	The automatic process that assess the water temperature in the exchanger to activate the next steps is in progress
72 - Water heater - waiting for supply air temperature	Unit is ventilating	The unit controls the temperature of the air flowing through the exchanger	The automatic process that assess the temperature of the air flowing through the exchanger to activate the next steps is in progress
73 - WCO detects temperature of the water supply (cold / hot)	Unit is ventilating	The unit controls the temperature of the liquid in the exchanger	The automatic process that assess the water temperature in the exchanger to activate the next steps is in progress
73 - Pre-freecooling active	Unit is ventilating	Temperature evaluation for freecooling mode in progress	Preparation for freecooling mode in progress. It evaluates the temperature and the conditions necessary to activate this mode.
74 – Flow reduction, minimum temperature in the duct not reached	Unit operates in a restricted mode	The unit is trying to reach the set values of the channel's minimum	The temperature of the air flowing into the inlet branch of the building has not been reached. The performance of the unit is being automatically corrected to reach this minimum level. Automatic process
75 - Passive house protection	Unit is not working	The unit is operating in order to meet the Passive house specifications	The temperature of the air flowing into the inlet branch of the building is not within the Passive House specifications. The performance of the unit is being automatically corrected to reach this minimum level. Automatic process
36 - B module error	Unit is not working	The unit can not control the peripherals connected to Module B	Unable to communicate with module B. Check whether the communication cable between motherboards A and B is damaged. If necessary, replace module B
76 - Heat pump defrost	Unit operates in a restricted mode	The unit is waiting until the heat pump defrosts.	The heat pump is reporting that it is defrosting. The unit is operating in defrost-waiting mode. Automatic process
37 - Condensate pan overflow	Unit is not working	The level sensor has detected an extremely high level of water in the condenser's pan	Check that the level sensor is connected correctly or check that it is operating correctly, or whether the condensate drain is not clogged, preventing the condensate from draining correctly.

MAINTENANCE

IF THE FAULT PERSISTS

If you are unable to rectify the fault, contact your supplier.

READ CAREFULLY!

Prepare the following information for quick troubleshooting:

- Have the following information ready for quick troubleshooting:
- product type data
- serial number operating time
- accessories used unit location
- wiring conditions (including electrical)
- a detailed description of the fault and the steps you have taken to rectify it
- Podrobný popis závady a kroky k jejímu odstranění

DECOMMISSIONING OF THE PRODUCT - DISPOSAL

Dispose of the product before disposal. Older units also contain materials that can be reused. Take them to a collection yard. It is better to have the product dismantled at a specialist centre, which will allow the recyclable materials to be reused. Dispose of unusable parts at a legal disposal site. Materials must be disposed of in accordance with applicable national regulations and guidelines.



CONCLUSION

To use the heat recovery unit correctly and safely, you must read this manual and follow the instructions. For any questions or requests for clarification, please do not hesitate to contact our sales or technical support department.

CONTACT

Address

2VV, s.r.o.,
Fáblůvka 568,
533 52 Pardubice,
Czech Republic

Internet :

<http://www.2vv.cz/>

