



PARTNER
IN VENTILATION
2VV.CZ

EN

ALFA 95 II ***horizontal***



**Installation
and operation
Manual**



4-118-0229



CONTENT

1. BEFORE YOU START	3
2. UNPACKING	4
3. MAIN COMPONENTS	5
4. DIMENSIONS	6
5. TECHNICAL PARAMETERS	8
6. INSTALLATION	10
6.1 SELECT UNIT LOCATION	10
6.2 CONNECTING AIR INLETS	13
6.2 CONNECTING MECHANICAL ACCESSORIES	14
6.3 CONNECTING ELECTRICAL ACCESSORIES	15
6.4 CONNECTING CONDENSATE OUTLET	23
7. COMMISSIONING	26
8. MAINTENANCE	27
8.1 FILTER REPLACEMENT	27
8.2 CLEANING INTERVALS	27
9. REMOVING FAULTS	28
10. SERVICE	33
10.1 IF THE FAULT PERSISTS	33
10.2. PUTTING THE UNIT OUT OF OPERATION - DISPOSAL	33
11. WIRING DIAGRAM	33
12. CONCLUSION	43

1. BEFORE YOU START

This manual includes the following symbols that will help you with orientation in the text.

Symbol		Meaning
	ATTENTION!	Warning or notification
	READ CAREFULLY!	Important instructions
	YOU WILL NEED	Advices and practical information
	TECHNICAL DATA	Detail technical information
		Link to another part of the user guide



Before connecting the unit, please read carefully the **Safe Operation of the Ventilation Unit** guide where you can find instructions for correct and safe operation of the product.

This manual includes important instructions for safe connection of the ventilation unit. Before connecting the unit, please read carefully and follow all the instructions below! The manufacturer reserves the right to make changes, including changes in the technical documentation, without previous notification. Please keep this manual for further references. Consider this manual a permanent part of the product.

EC DECLARATION OF CONFORMITY

The product was designed, manufactured, and placed on the market, it complies with all relevant provisions and requirements of the European Parliament and the Council, including amendments, which it was classified under. The product is safe under normal conditions of installation and use. The conditions are defined in the Operating instructions. The product's safety evaluation was based on the harmonized European standards listed in the relevant EC declaration of conformity.

The current full version of the EC Declaration of conformity is available at www.2vv.cz

2. UNPACKING

2.1 CHECK THE SUPPLY

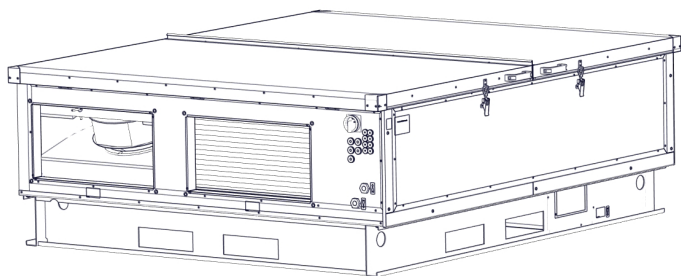

READ CAREFULLY!

- Upon delivery, check the product packaging for possible damage. If the packaging is damaged, notify the carrier. If the claim is not made in due time, any claims thereafter cannot be considered.
- Check whether the product Typee corresponds to your order. If the product Typee does not correspond, do not unpack it and contact the supplier immediately.
- After unpacking the unit, check its condition and condition of all its components. In case of doubt contact the supplier.
- Never use a damaged unit.
- If the unit is not unpacked immediately after its receipt, it must be stored in a dry place at temperatures from +5°C to +35°C.

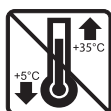

2.2 UNPACK THE UNIT

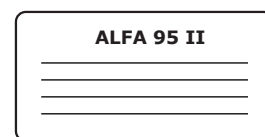
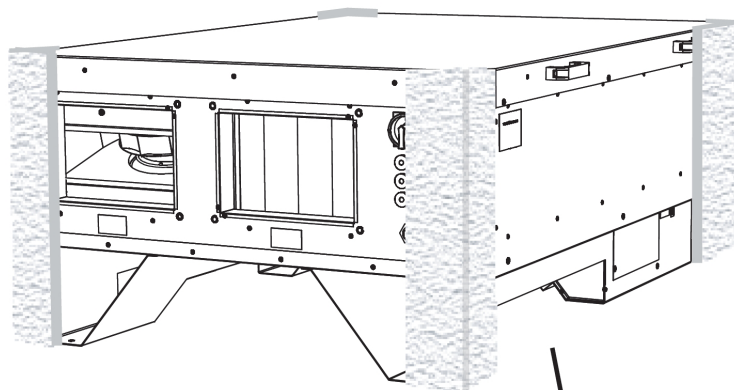

READ CAREFULLY!

- If the ventilation unit was exposed to temperatures lower than 0 ° C during transport, keep it unpacked for at least 2 hours at room temperature before connecting it. This ensures that there is no difference between temperatures inside and outside the unit.



This product must be disposed of in accordance with local laws and regulations. The product contains batteries and therefore it must be recycled or disposed of separately from the household waste. When the battery or the product reaches the end of its service life, contact your dealer or local authorities and ask about recycling options. The separate collection and recycling of your product and its battery will help to preserve natural resources and ensure that the product will be recycled in a manner that protects human health and the environment.

3. MAIN COMPONENTS

Size 800 / 1500 / 2500 / 3500 / 4500 / 5500



To connect use CAT5 UTP cable.
CABLE NOT INCLUDED



External temperature sensor
Shielded cable max. 50 m with a cross. 0.5 mm
CABLE NOT INCLUDED



Water overflow sensor. Contact On/OFF.
Cable length 3 m

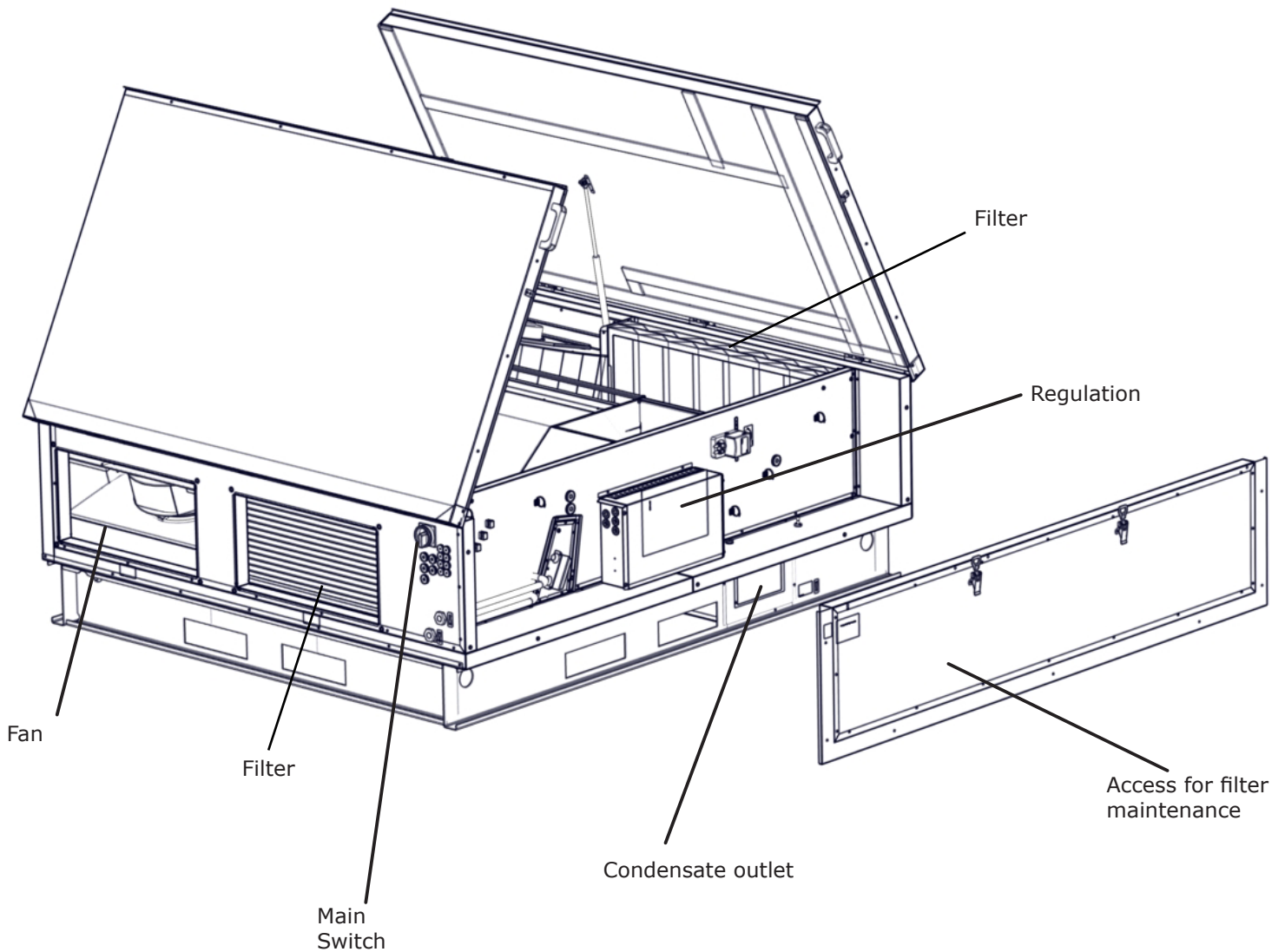

4. DIMENSIONS

Size **800 ~ 3500**

bottom view

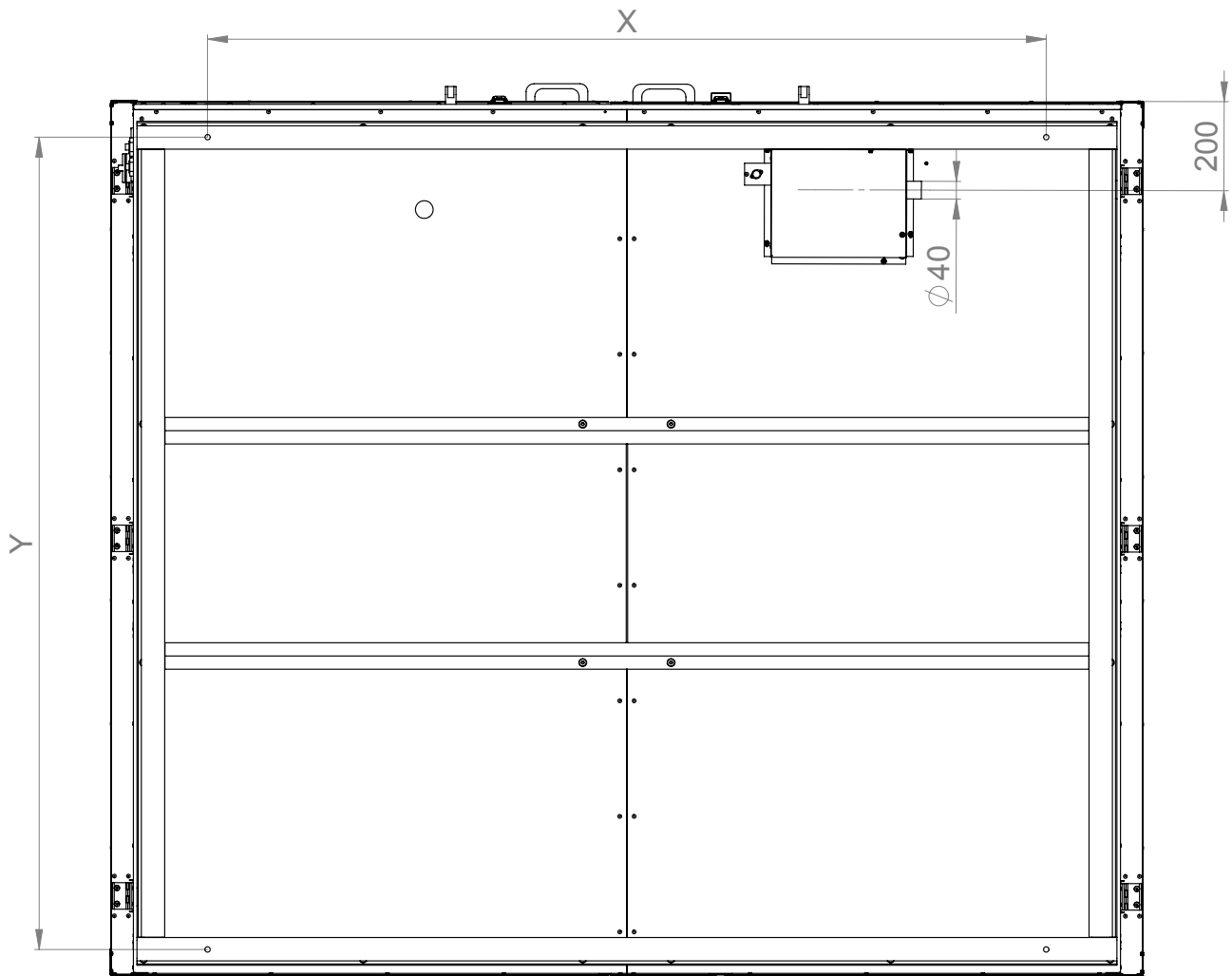

Typ	A	B	B1	C	D1	D2	E1	E2	F1	F2	G1	G2	X	Y
HR95-080	1540	1100	1060	410	224	324	200	300	275	85	405	72	1300	890
HR95-150	1830	1540	1500	450	274	524	250	500	319	86	601	62	1600	1330
HR95-250	2140	1855	1815	540	324	624	300	600	368	82	770	62	1900	1650
HR95-350	2340	2020	1980	700	424	724	400	700	351	82	852	87	1900	1850

All dimensions are in mm

Side view 1 (regulation)

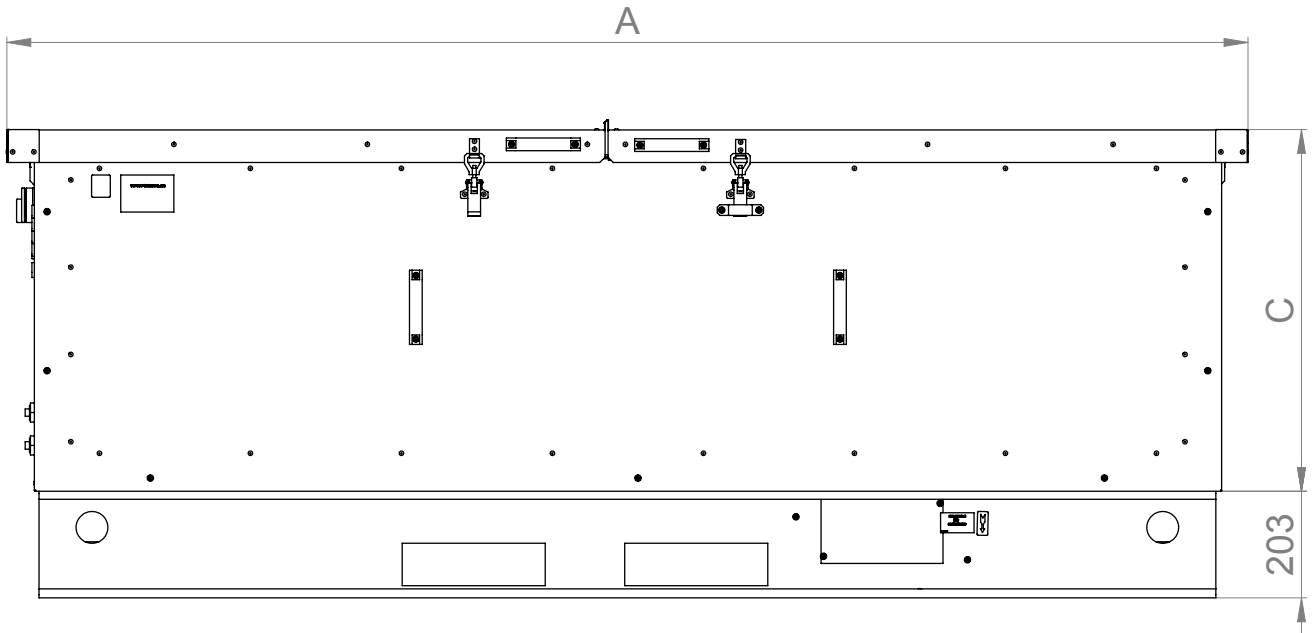

Side view 2 (intake / exhaust)

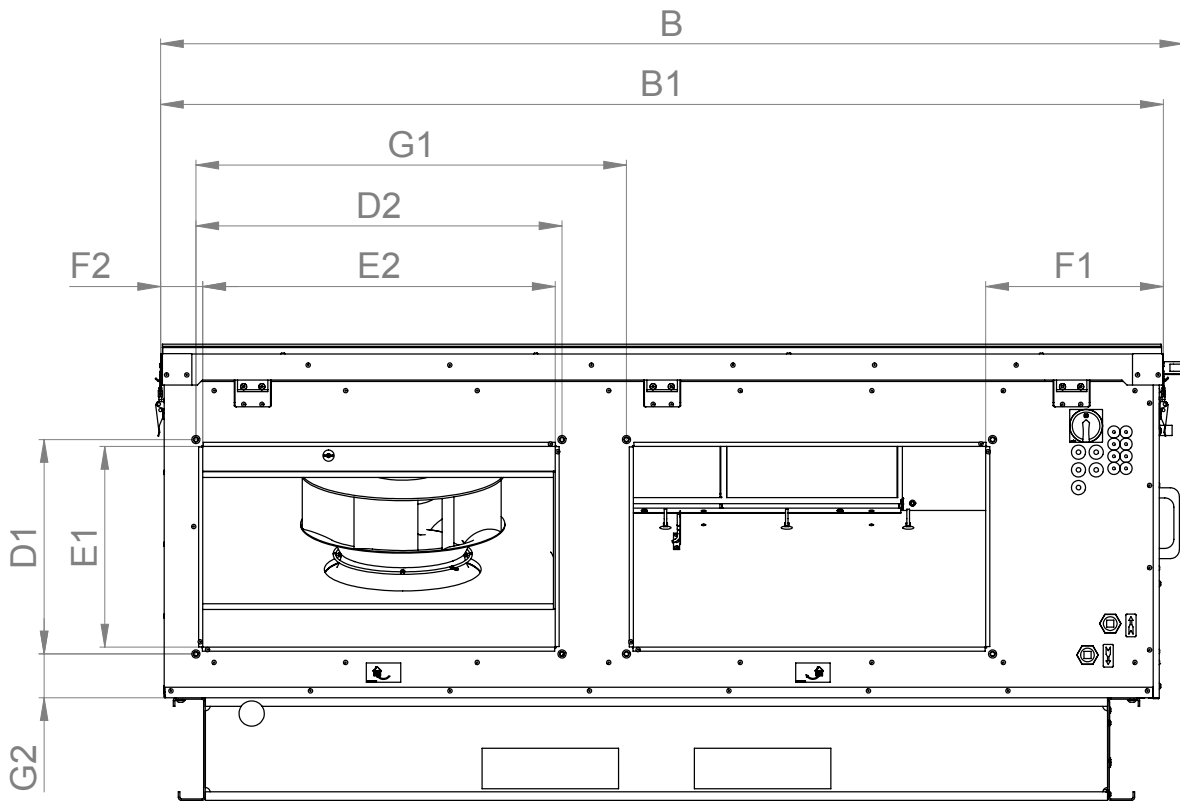

5. TECHNICAL PARAMETERS

Ventilator parameters (for 1 ventilator)

Type	Number of phases	Voltage [V]	Frequency [Hz]	Power consumption [W]	Current [A]	Operating temperature min. [°C]	Operating temperature max. [°C]
HR95-080EC-...-....	1	230	50	200	1,4	-25	60
HR95-150EC-...-....	1	230	50	500	3,1	-25	40
HR95-250EC-...-....	1	230	50	500	3,1	-25	60
HR95-350EC-...-....	3	400	50	1000	1,7	-25	50

Electric preheater parameters

Type	Number of phases	Voltage [V]	Frequency [Hz]	Power consumption [W]	Current [A]
HR95-080...-...-...E.	1	230	50	2700	11,8
HR95-150...-...-...E.	3	400	50	5300	13,3
HR95-250...-...-...E.	3	400	50	8300	12,1
HR95-350...-...-...E.	3	400	50	11700	16,9

Electric reheater parameters

Type	Number of phases	Voltage [V]	Frequency [Hz]	Power consumption [W]	Current [A]
HR95-080...-...-...E	1	230	50	1800	8,8
HR95-150...-...-...E	1	230	50	3700	18
HR95-250...-...-...E	3	400	50	5800	13,5
HR95-350...-...-...E	3	400	50	8300	19,5

Hot-water reheater parameters

Type	Air flow [m³/h]	Power (W)*	Pressure drop in the water flow [kPa]	Pressure drop in the air flow [Pa]	connection cross-section
HR95-080...-...-...W	800	6300	20	20,8	1/2"
HR95-150...-...-...W	1500	12100	58,3	28,4	1/2"
HR95-250...-...-...W	2250	20300	27,8	27	1/2"
HR95-350...-...-...W	3500	29800	32,7	18,6	1/2"

* for water 90/70 and the inlet temperature = +15 °C

CO exchanger parameters (Heating mode)

Type	Connection cross-section ["]	Pressure drop in the air flow [Pa]	Pressure drop in the water flow [kPa]	Power [W]	Air flow [m ³ /h]	Media flow [m ³ /h]	Temperature after exiting the heat exchanger [°C]
HR95-080EC-...C	3/4	75	2,0	6600	800	0,29	39,2
HR95-150EC-...C	3/4	76	0,8	10240	1500	0,45	35
HR95-250EC-...C	1	83	1,5	19770	2500	0,86	38,2
HR95-350EC-...C	1 1/2	62	1,3	29400	3500	1,28	39,7

For water 60/40 and the inlet temperature = +15 °C

CO exchanger parameters (Cooling mode)

Type	Connection cross-section ["]	Pressure drop in the air flow [Pa]	Pressure drop in the water flow [kPa]	Power [kW]	Air flow [m ³ /h]	Media flow [m ³ /h]	Temperature after exiting the heat exchanger [°C]
HR95-080EC-...C	3/4	84	18,5	5,22	800	0,9	15
HR95-150EC-...C	3/4	86	7,5	7,92	1500	1,36	16,7
HR95-250EC-...C	1	93	13,2	15,46	2500	2,65	15,4
HR95-350EC-...C	1 1/2	69	12,0	23,12	3500	3,97	14,8

For water 7/12 and the inlet temperature = +25 °C

Direct evaporator (Cooling mode)

Type	Air flow [m ³ /h]	Power [W]	Temperature after exiting the heat exchanger [°C]	Humidity after exiting the heat exchanger [%]	Coolant pressure loss [kPa]	Pressure drop in the air flow [Pa]	Connection cross-section gas (liquid) ["]
HR95-080EC-...D	800	5410	15,1	89,9	16,4	66	5/8 (1/2)
HR95-150EC-...D	1500	10120	15,2	89,5	33,0	77	7/8 (5/8)
HR95-250EC-...D	2500	17190	15	89,6	45,1	72	1 1/8 (5/8)
HR95-350EC-...D	3500	25530	14,5	90,3	48,4	53	1 3/8 (1 1/8)

Data applies for the inlet temperature = +25°C, 70% RH and the evaporation temperature +5°C, coolant R410A

6. INSTALLATION

6.1 SELECT UNIT LOCATION

TECHNICAL DATA

- The unit intended for outdoor installation only may be installed in the outdoor unprotected environment with the temperature -20°C to +60°C

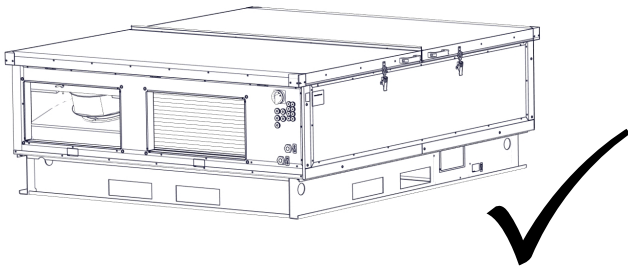
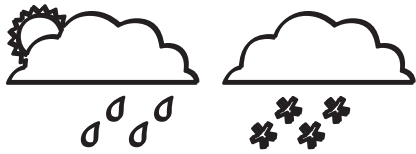

*The air-flow temperature inside the unit should range from -20°C to +60°C, the maximum humidity is 90%.

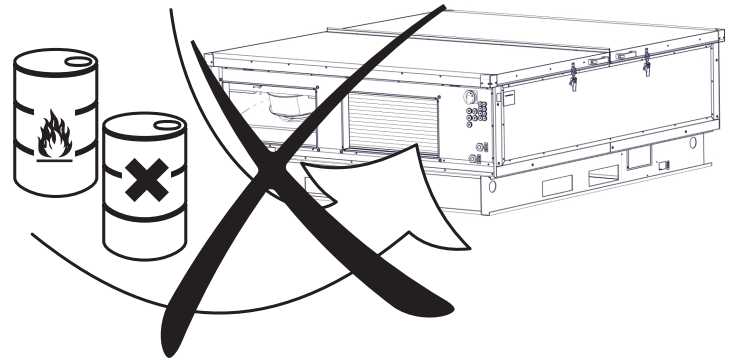

The unit is not designed for air containing flammable or explosive mixtures, chemical vapours, heavy dust, soot, grease, toxins, pathogenic organism, etc.
The electric protection index of units is IP 43 (designed for outdoor environments).

6.1-1 Access distances needed for servicing the unit

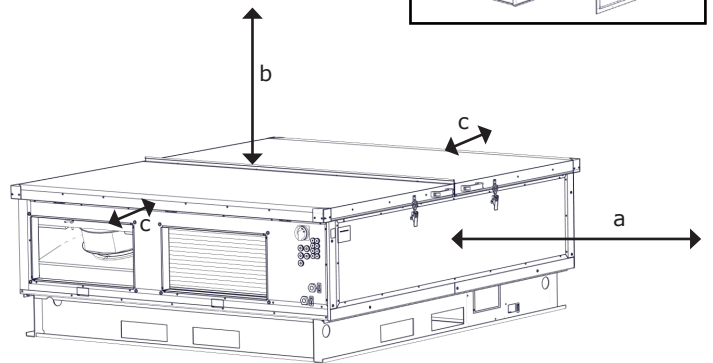
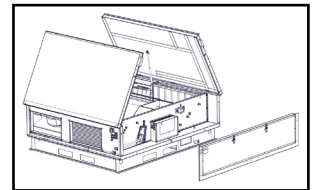

Type	a	b	c
HR95-080...-....	1000	1000	100
HR95-150...-....	1000	1000	100
HR95-250...-....	1000	1000	100
HR95-350...-....	1000	1200	100

All dimensions in the table are in mm

6. INSTALLATION

TECHNICAL DATA

- All types of ventilation units must be installed in a horizontal position. Other positions are not allowed.

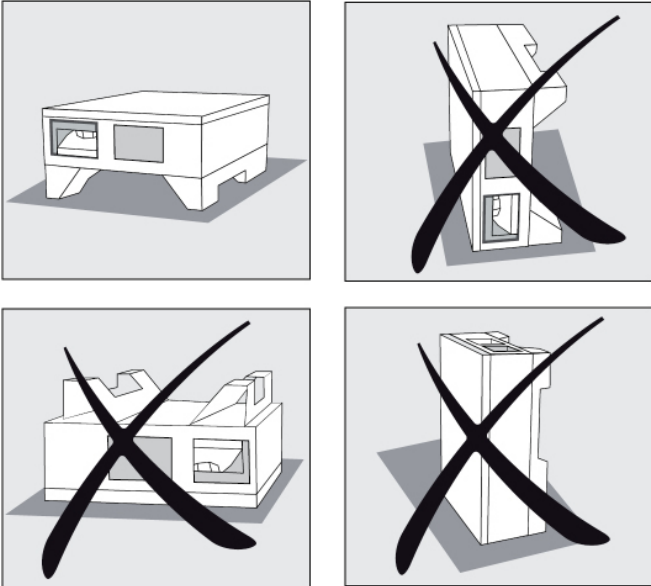

The unit must be installed so the air exhaustion direction corresponds with the air flow direction in the distribution piping.

The unit must be installed so it is possible to perform maintenance, repairs or disassembly. This means in particular access to inspection flaps and the possibility to open them, access to the control unit box cover, to connections of side units, and to the air filter cover.

6.1-2 Safe installation distance

ATTENTION!

- All materials used in a distance shorter than 100 mm from the ventilation unit must be non-flammable (they do not burn, flame up, burn out) or little flammable (they do not burn, decompose – e.g. drywall). However, these materials must not cover the unit's inlets and outlets.
- The safe distance of flammable materials from the unit's outlets is 500 mm.
- The safe distance of flammable materials in other directions is 100 mm..

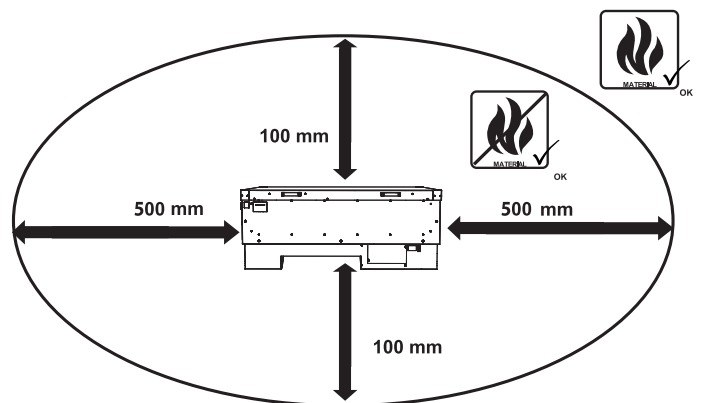
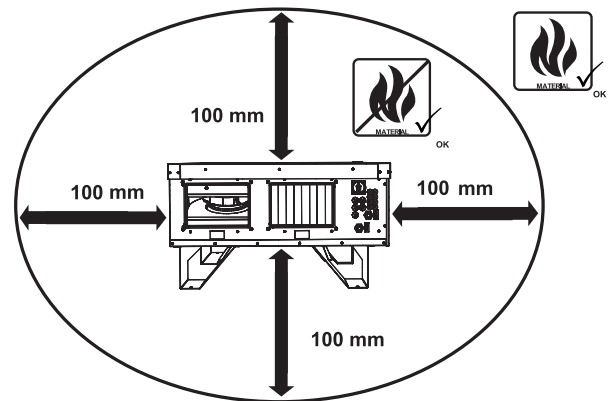

6. INSTALLATION

6.1-3 Unit anchoring

The anchoring points must be set out according to the following drilling template.

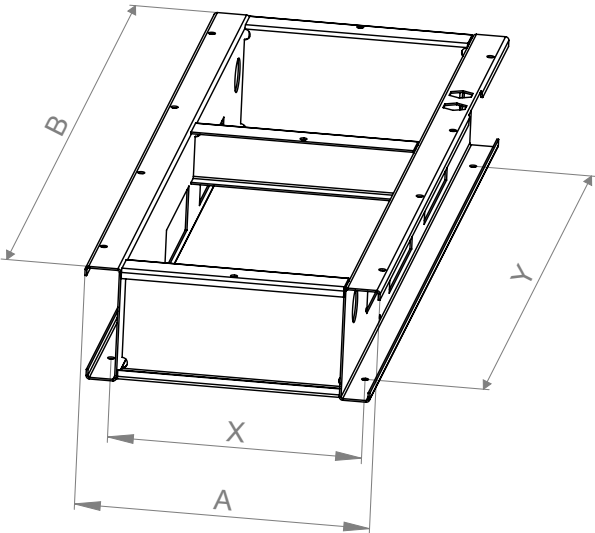

Fixing of the unit by 4 ~ 8 M10 bolts at the bottom of the bracket

Type	A	B	X	Y	Kg*
HR95-080...-...-...	972	1420	920	1300	192
HR95-150...-...-...	1426	1710	1354	1600	298
HR95-250...-...-...	1751	2030	1679	1900	399
HR95-350...-...-...	1911	2220	1839	1900	520

all dimensions are in mm

* - the total weight of the heaviest unit in the category

ATTENTION!

- The unit must be fixed to the base so it cannot move accidentally.
- With respect to the weight of the unit, it is necessary to use a corresponding handling device to lift it up (e.g. a forklift).

YOU WILL NEED

- 4 ~ 8 self-locking nuts, size M8 (depending on the unit's type)
- 4 ~ 8 threaded rods
- 4 ~ 8 dowels of a corresponding type and dimensions (depending on the material of the ceiling and the unit's weight).
- drill and drill bits of corresponding dimensions
- pliers and the corresponding spanner

Place the unit in a horizontal position then tilt it about 3° so that the condensate can drain away. Fasten the unit with screws.

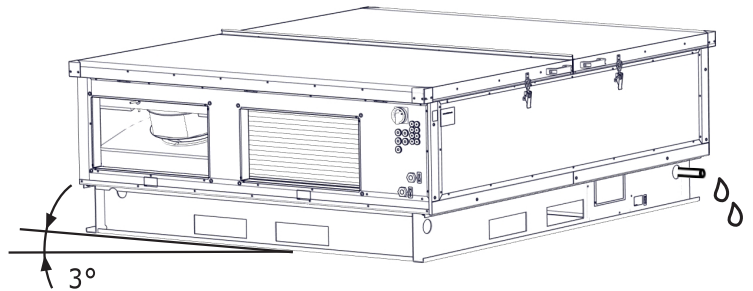

6. INSTALLATION

6.2 CONNECTING AIR INLETS

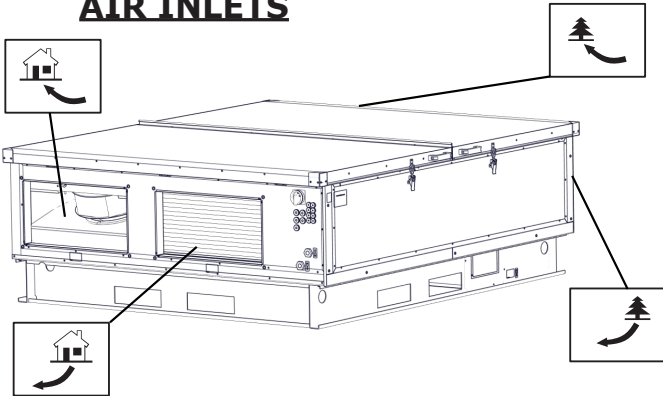

6.2-1 Pipe connection hole - circular/rectangular

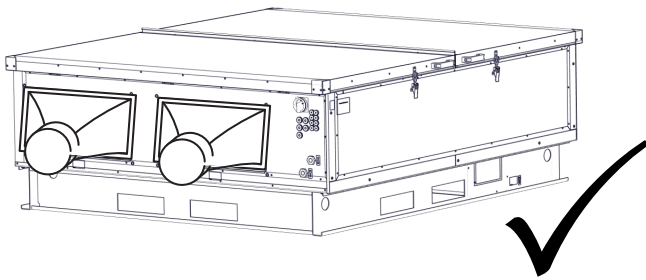

This is an accessory part which must be ordered separately

Example of possible connection with flexible connectors. (We do not supply this accessory)

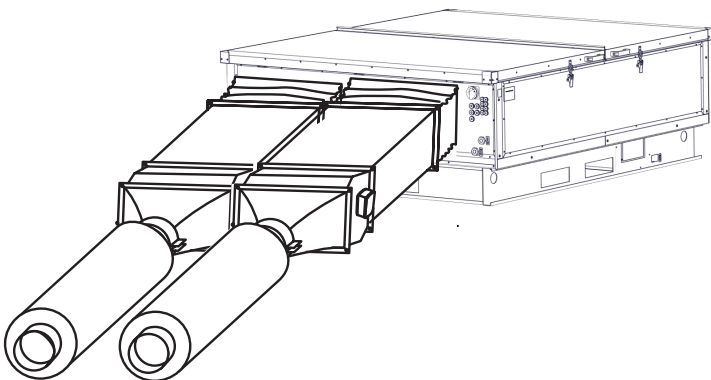

YOU WILL NEED

- 16 M8 bolts (4 screws are supplied with each transition for rectangular/circular pipes)
- 4 sockets for connecting rectangular/circular pipes (accessories)
- corresponding spanner
- sealing tape / sealant

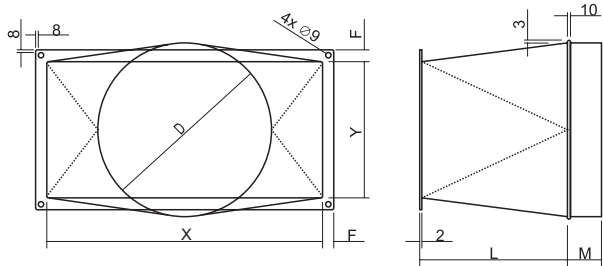

Type	X	Y	D	L	M	F
HR95-080.....	300	200	250	200	50	20
HR95-150.....	500	250	315	250	70	20
HR95-250.....	600	300	400	300	70	20
HR95-350.....	700	400	500	400	70	20

All dimensions are in mm

READ CAREFULLY!

- The connected pipes must have the same dimensions as the unit's inlets and outlets. Smaller diameter pipes may cause a decrease in the unit's efficiency. In some cases, they may lead to shortening of the unit's lifetime.
- Connect the inlets and outlets (rectangular/circular hole). Use flexible joints to prevent vibrations.

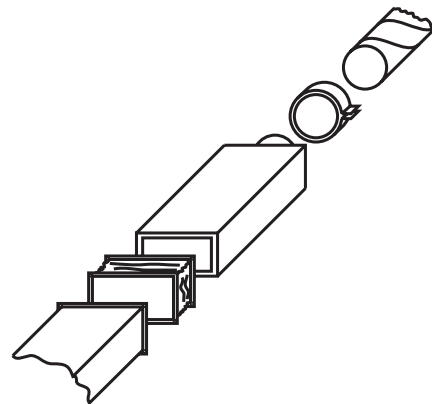

All connections of the distribution piping to the ventilation unit must be sealed with a sealant or sealing tape.

The minimum distance between pipes or adapters and the unit's neck is 500 mm.

6. INSTALLATION

6.2-2 Protection of the unit's inlets and outlets (not included)

If an inlet or outlet is not connected to the pipe, a rain louvre must be used to prevent water and solid particles from coming into contact with the ventilator, heating elements, etc.

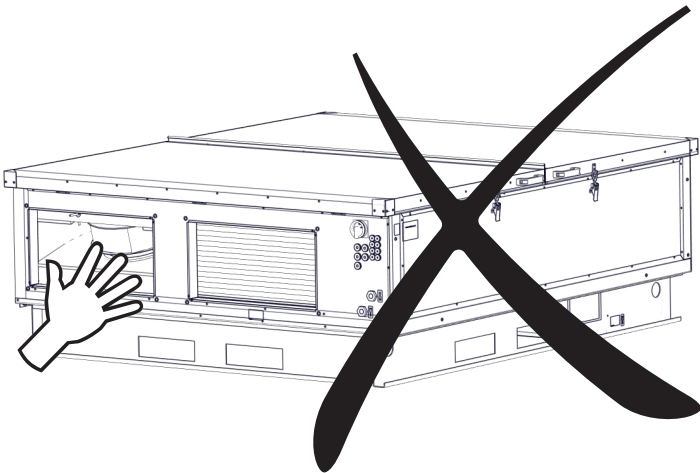

Accessories that must be ordered separately

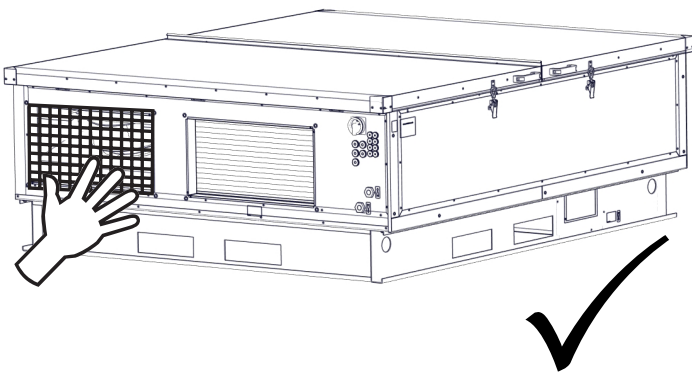

6.3 CONNECTING MECHANICAL ACCESSORIES

6.3-1 Air flap

These rectangular flaps are used to close the air inlets connected to the ventilation unit.

Accessories that must be ordered separately

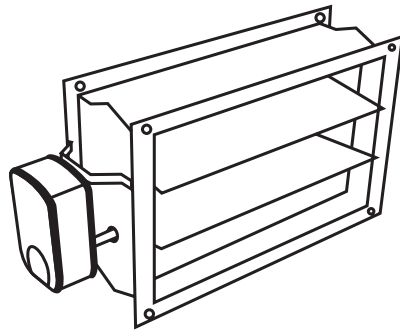

YOU WILL NEED

- 2 rectangular flaps (of corresponding dimensions)
- 2 actuators (with one or two wires, voltage 230 V)
- 8 M8 bolts and nuts
- 16 washers
- corresponding spanner
- flat tip screwdriver, Phillips screwdriver, sealing tape, and sealant

6. INSTALLATION

Types of rectangular flaps

Types of rectangular flaps	
HR95-080...-...-...	MLKR/S-300200-04N1-0
HR95-150...-...-...	MLKR/S-500250-04N1-0
HR95-250...-...-...	MLKR/S-600300-04N1-0
HR95-350...-...-...	MLKR/S-700400-04N1-0

Install one flap approx. 2 m before the fresh air-suction neck of the pipe, then install another flap on the exhaust pipe, approx. 2 m from the neck. Connect servomotors to corresponding terminals in the casing of the control unit. See chapter Connecting wiring and electrical accessories

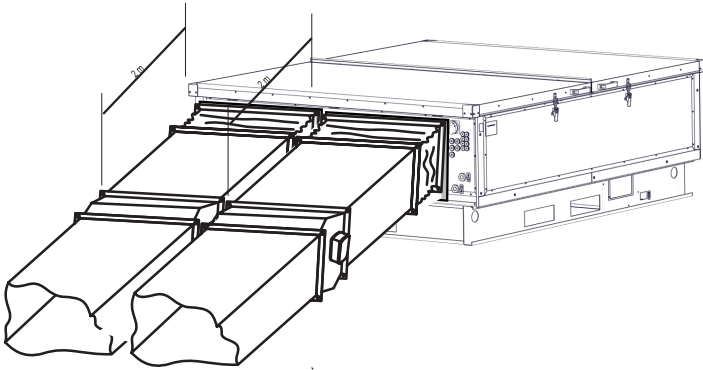

Set the flap to a completely closed position if the unit is off and to a completely opened position if the unit is running. Setting the flap to a different position may damage the unit.

6.4. CONNECTING ELECTRICAL ACCESSORIES

ATTENTION!

- **Before any intervention in the ventilation unit, the main power switch must be off!**
- *The ventilation unit's electrical wiring must correspond to a layout designed by a professional electrician. The electrical wiring must be done by a person authorized to perform electrical installations. It is necessary to follow all instructions in this manual and to comply with local laws and regulations.*
- *The wiring diagrams depicted on the product take precedence over diagrams in this manual! Before connecting the wiring, make sure that terminal indications match the diagram. If in doubt, contact the supplier and do not connect the unit!*
- *If the product is connected to other than original control system, contact the supplier of such system for the wiring diagram of individual controls.*
- *The unit must be connected to the mains using a heat-protected rigid insulated cable with the cross-section that corresponds to local regulations.*
- *To maintain the electrical protection, all cables must fit in the holes on the sides of the control unit casing.*
- *Any interventions or modifications of the internal wiring of the unit are prohibited and lead to loss of warranty!*
- *The unit's correct operation can only be guaranteed when original accessories are used.*
- *If it is necessary to install a sensor or a regulation component in the unit or on its casing, please consult its location with the unit manufacturer (or with its representative).*

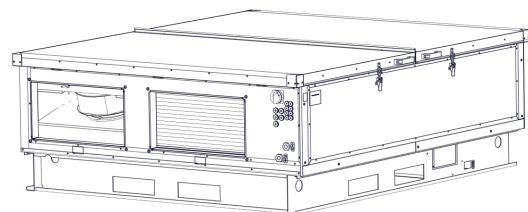

6. INSTALLATION

6.4-1 Supply cable

Wiring terminals for the power cord are located inside the casing of the control unit.

ATTENTION!

Minimum size of the protective grounding cable must be in compliance with local safety regulations regarding heavy current lead through a device's protective grounding cable.

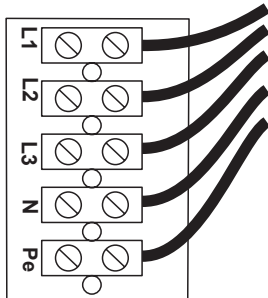

TECHNICAL DATA

- Wiring parameters can be found on the label installed on the control device casing.

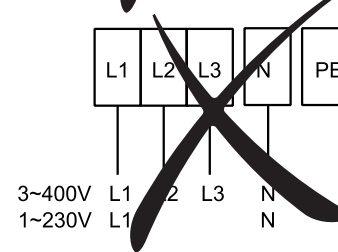
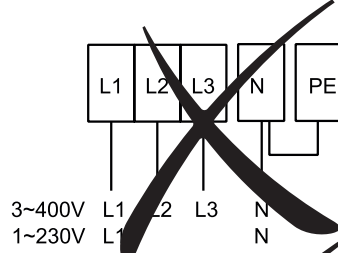
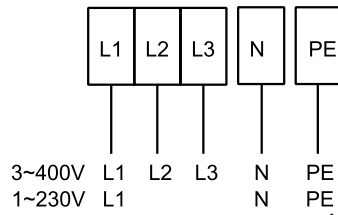
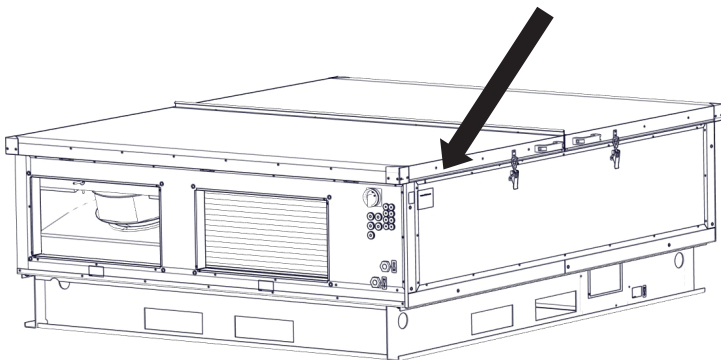

All phases of the electric power supply must be connected through the corresponding type of circuit breaker. The distance between disconnected contacts must be larger than 3 mm.

It must be possible to disconnect the unit from the electric power supply with a single power switch.

Information on product type

U = voltage	I = current
f = frequency	P = output/input
n = fan speed	m = weight
ph = number of phases	IP = electrical protection
av = airflow	ver = version

serial number

- The unit must be connected to TN-S network, this means that the neutral conductor must always be connected.

6. INSTALLATION

The recommended values for lead-in cables and circuit breakers

Units with integrated preheating

Type	Number of phases	Voltage (V)	Power (W)	Current (A)	Type of cable*	Type of circuit breaker (A)*
HR95-080.....E.	1	230	2700	14,4	3Cx1,5	16
HR95-150.....E.	3	400	5300	13,3	5Cx1,5	16
HR95-250.....E.	3	400	8300	18,2	5Cx2,5	20
HR95-350.....E.	3	400	11700	20,4	5Cx2,5	25
HR95-450.....E.	3	400	15000	25,2	5Cx4	32
HR95-550.....E.	3	400	18300	32	5Cx6	40

* - Recommended values. values must be specified by the person responsible for the wiring in the building (e.g. designer) with regard to parameters of the power line wiring and other parameters of the building

Units with integrated electric reheater

Type	Number of phases	Voltage (V)	Power (W)	Current (A)	Type of cable*	Type of circuit breaker (A)*
HR95-080.....E	1	230	1400	8,7	3Cx1,5	16
HR95-150.....E	1	230	2700	18	3Cx2,5	20
HR95-250.....E	3	400	4800	13,1	5Cx1,5	16
HR95-350.....E	3	400	6500	12,9	5Cx1,5	16
HR95-450.....E	3	400	7700	14,6	5Cx1,5	16
HR95-550.....E	3	400	10700	21	5Cx2,5	25

* - Recommended values. values must be specified by the person responsible for the wiring in the building (e.g. designer) with regard to parameters of the power line wiring and other parameters of the building

Units with integrated electric preheater and reheater

Type	Number of phases	Voltage (V)	Power (W)	Current (A)	Type of cable*	Type of circuit breaker (A)*
HR95-080.....EE	3	400	4100	11,8	5Cx1,5	16
HR95-150.....EE	3	400	8000	18	5Cx2,5	20
HR95-250.....EE	3	400	13100	25	5Cx4	32
HR95-350.....EE	3	400	18200	29,8	5Cx4	32
HR95-450.....EE	3	400	22700	36,3	5Cx6	40
HR95-550.....EE	3	400	29000	47,5	5Cx10	50

* - Recommended values. Values must be specified by the person responsible for the wiring in the building (e.g. designer) with regard to parameters of the power line wiring and other parameters of the building

6. INSTALLATION

6.4-2 Electrical accessories

Connect the unit's electrical accessories to the terminal box located in the regulation box according to the scheme of wiring and terminal designations.

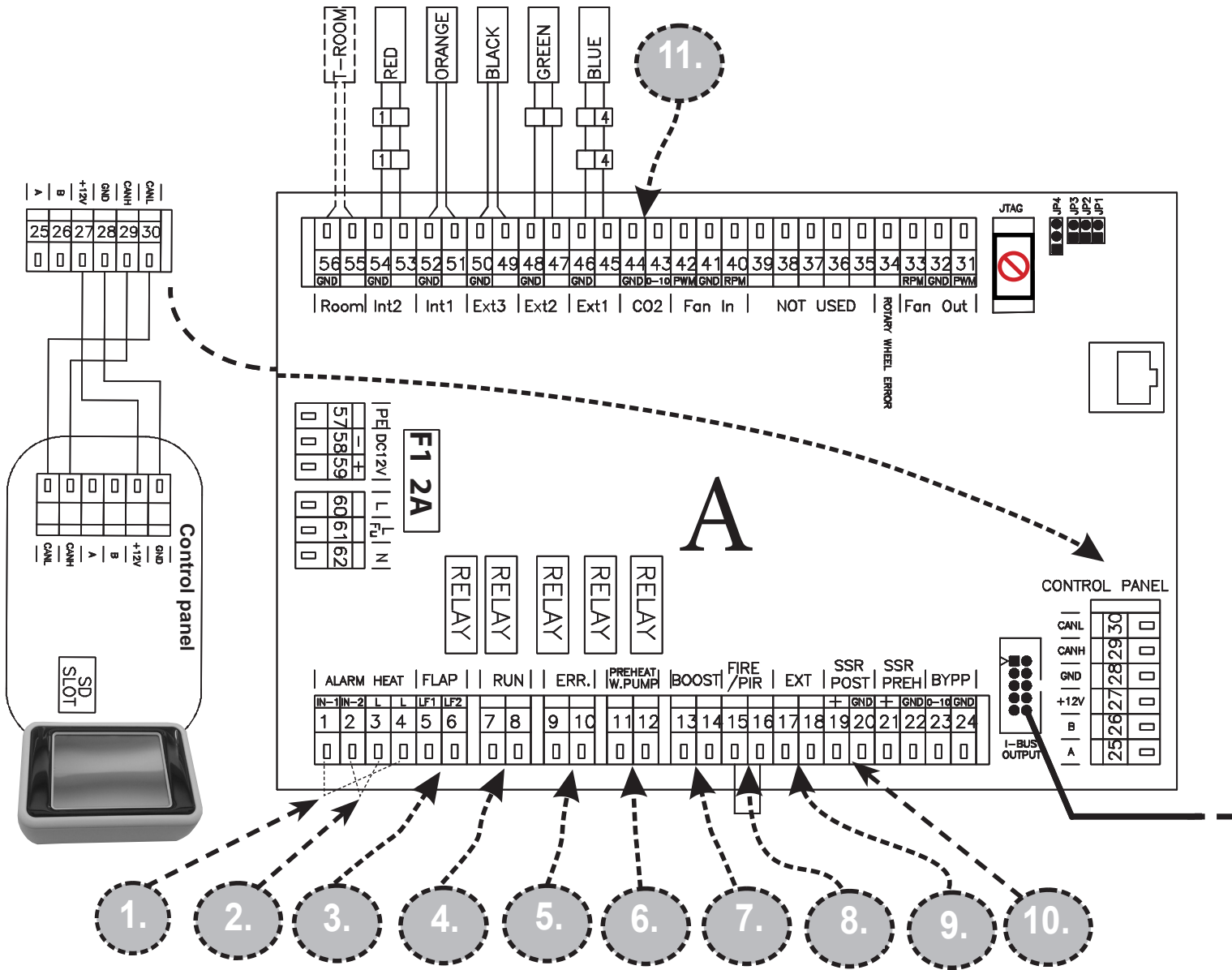

1.	A (1,4)	SAFETY THERMOSTAT POSTHEATING
2.	A (2,3)	SAFETY PREHEATING THERMOSTAT
3.	A (5-6)	LF1 - FLAP INLET (output L-open), LF2 - FLAP OUTLET (output L-open)
4.	A (7-8)	RUN CONTACT (output -NO/NC settable)
5.	A (9-10)	ERROR CONTACT (output NO)
6.	A (11-12)	PREHEATER WATER PUMP (11 - Lint, 12 - Lout)
7.	A (13-14)	BOOST (input NO)
8.	A (15-16)	FIRE (input NC)
9.	A (17-18)	EXTERNAL CONTROL ON/OFF (input NC)
10.	A (19,20)	OUTPUT PERFORMANCE OF POSTHEATING (0-10V OR PWM)
11.	A (43,44)	AQS SENSOR 0-10V (input)

6. INSTALLATION

🔍 READ CAREFULLY!

- Wiring scheme is located on the inside of the regulation box's removable cover.
- Each accessory must be connected with a supplied cable, or with a cable that corresponds with specifications of individual components.

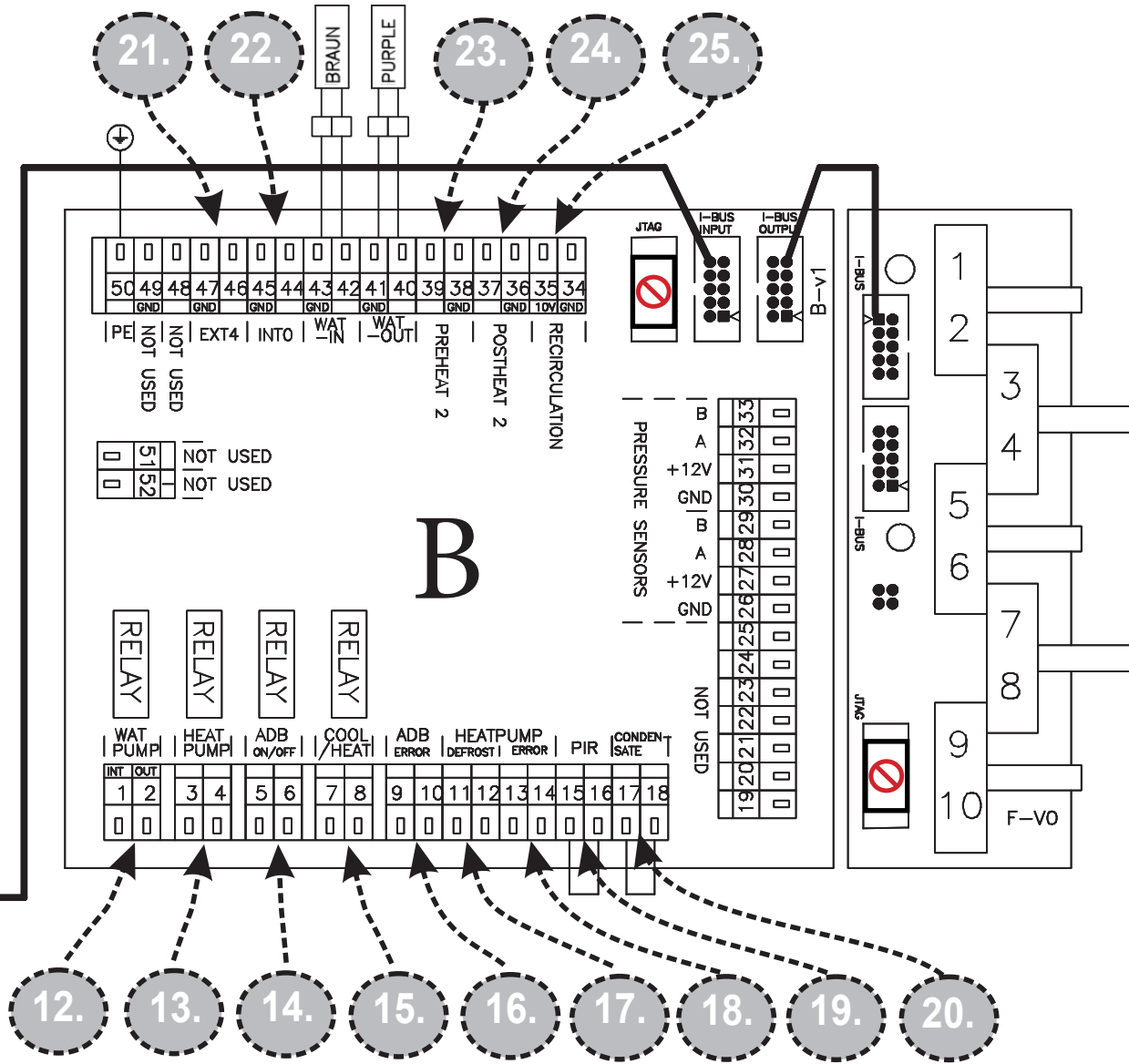

12.	B (1-2)	WATER PUMP (1 - Lint, 2 - Lout)
13.	B (3-4)	HEAT PUMP CONTROL settable (output - ON/OFF)
14.	B (5-6)	ADIABATIC MODULE (output - ON/OFF)
15.	B (7-8)	COOL / HEAT settable (CO = NC/NO - DX = output settable)
16.	B (9-10)	ADIABATIC MODULE ERROR (input NO)
17.	B (11-12)	HEAT PUMP DEFROST settable (input NC/NO)
18.	B (13-14)	HEAT PUMP ERROR settable (input NC/NO)
19.	B (15-16)	PIR (input NC)
20.	B (17-18)	CONDENSATE OVERFLOW (input NC)
21.	B (46-47)	EXTERNAL TEMPERATURE SENSOR (external postheater - input)
22.	B (44-45)	EXTERNAL TEMPERATURE SENSOR (adiabatic module / recirc. chamber - input)
23.	B (38-39)	EXTERNAL PREHEATER (output - Water= 0-10V)
24.	B (36-37)	EXTERNAL POSTHEATER (output - Water= 0-10V)
25.	B (34-35)	RECIRCULATION CHAMBER (output 0-10V)

6. INSTALLATION

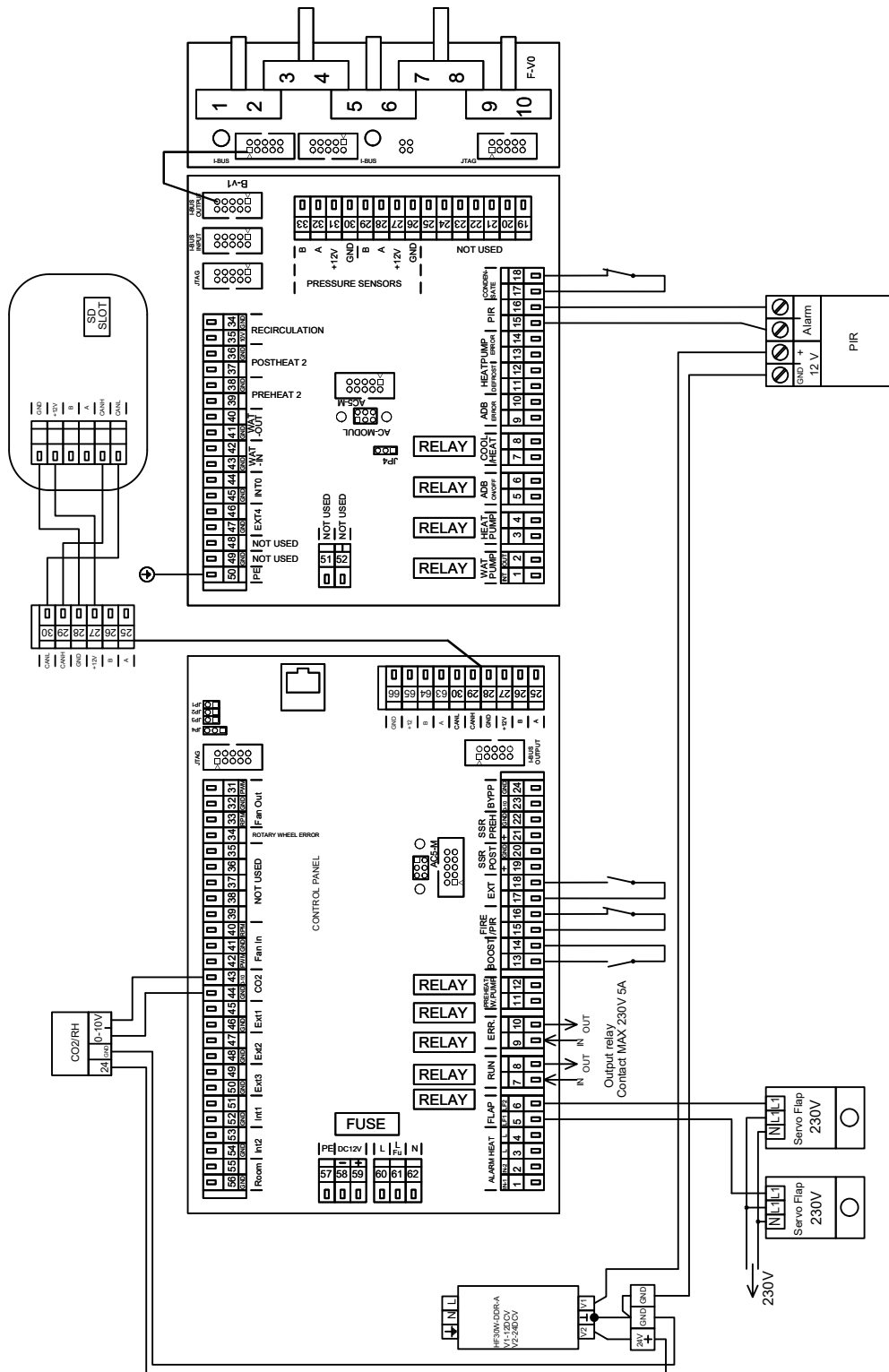

6. INSTALLATION

6.4 – 2.1 Non-integrated electric preheater (accessories)

TECHNICAL DATA

- Pipe heater powered by 400 V AC and control voltage 0-10V DC
- CABLE: size of the power cord should be chosen according to the heater's output/input and according to conditions of the connection. The minimum sizes for the recommended outputs/inputs are listed in Chapter 6.4-1 Power Cable
- Control cable of the electric heater - cable with two conductors with the minimum cross-section of 0.5 mm² Maximum length of 50 m.

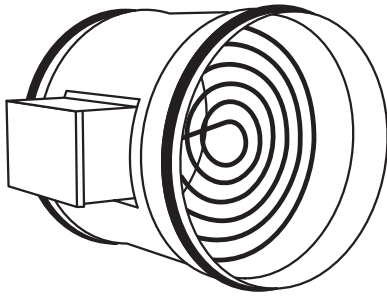

Not part of the supply

Recommended types of electrical preheating

Types of ventilation units	Type of preheating	Total power [kW]	Current [A]
HR95-080...-.....	EOKO-250-3,0-3-D	3	4,3
HR95-150...-.....	EOKO-355-7,5-3-D	7,5	10,8
HR95-250...-.....	EOKO-400-7,5-3-D	7,5	10,8
HR95-350...-.....	EOKO-560-12,0-3-D	12	17,3

6.4-2.2 External control

TECHNICAL DATA

- Low voltage switching contact - maximum possible contact load 12 V, 0.4 A.
- CABLE: cable with two conductors with a min. cross-section of 0.5 mm² Maximum length of 50 m.
- The contact is normally closed. When opening the contact, the unit turns off.

Not part of the supply

6.4-2.3 Fire contact

TECHNICAL DATA

- Low voltage switching contact - maximum possible contact load 12 V, 0.4 A.
- CABLE: cable with two conductors with a min. cross-section of 0.5 mm² Maximum length of 50 m.
- The contact is normally closed. When disconnected, the ventilation unit operates according to the pre-set output.



The required output can be set in the service menu - Chapter 7.6-12

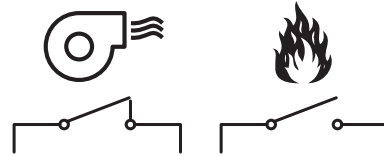

Not part of the supply

6.4-2.4 Servomotor for closing air inlet regulators with spring (Accessories)

TECHNICAL DATA

- Servomotor LM230 is supplied with 230 V AC – three-conductor control cable

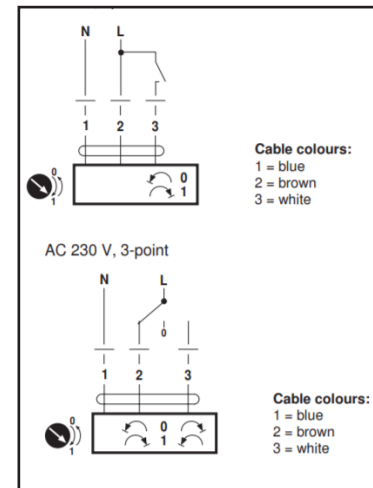

Not part of the supply

6. INSTALLATION

6.4-2.5 Mixing valve for water exchanger SMU 2

TECHNICAL DATA

- Servomotor SMU is supplied with 230V and 24VAC – three-conductor control cable

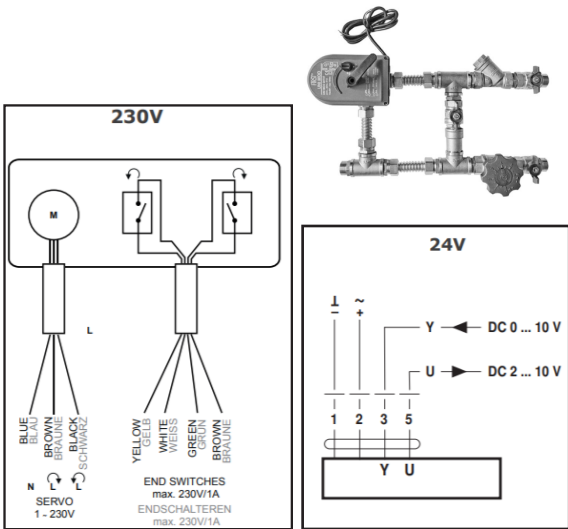

Not part of the supply

6.4-2.6 Movement sensor

Low-voltage switching contact - maximum possible contact load 12 V, 0.4 A
 CABLE: cable with two conductors with a min. cross-section of 0.5 mm² Maximum length of 50 m. Contact is normally open. When connected, the ventilation unit operates according to the pre-set ventilation output.



The required output can be set in the service menu - Chapter 7.6-2

6.4-3 Control unit

To activate the unit, it is necessary to connect the remote control and the unit using a control cable (data cable)

- slacken the bolt on the bottom of the remote control
- open the case of the remote control.
- cut a hole for the cable
- insert the control cable to the connector of the remote control
- fix the control panel to the wall
- close and tighten the control panel case

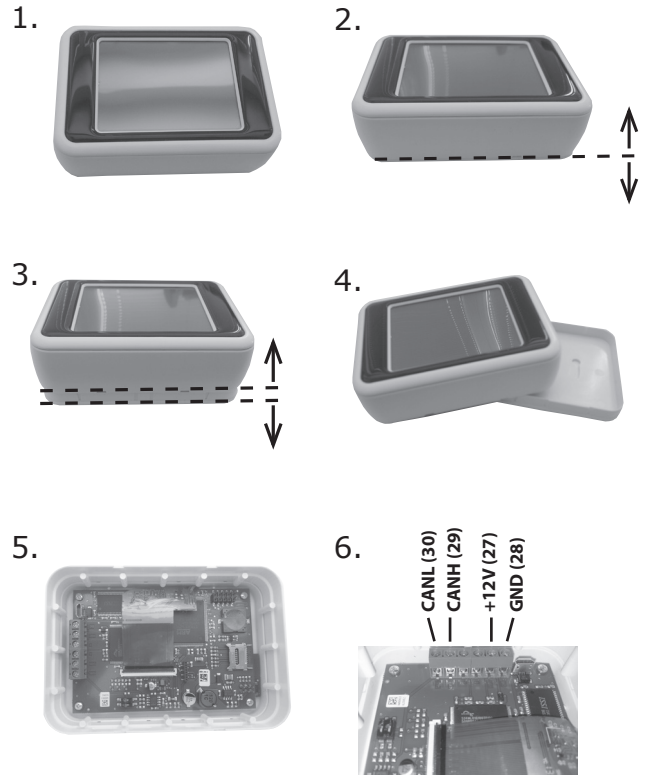

- insert the other end of the cable to one of the connectors on the electronic board.

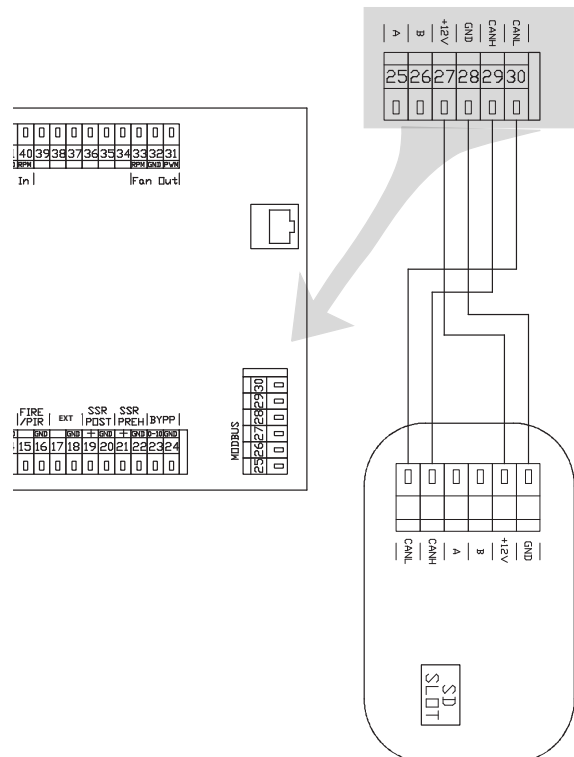

6. INSTALLATION

If the unit has a direct evaporator or C/O, it is necessary to connect a new trap (not included).

YOU WILL NEED

- 1 drain trap
- PVC discharge pipe
- discharge pipe sealing

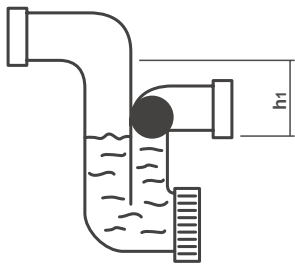

Unit type	h1 [mm]
HR95-080..-.-.....	130
HR95-150..-.-.....	130
HR95-250..-.-.....	130
HR95-350..-.-.....	130
HR95-450..-.-.....	130
HR95-550..-.-.....	130

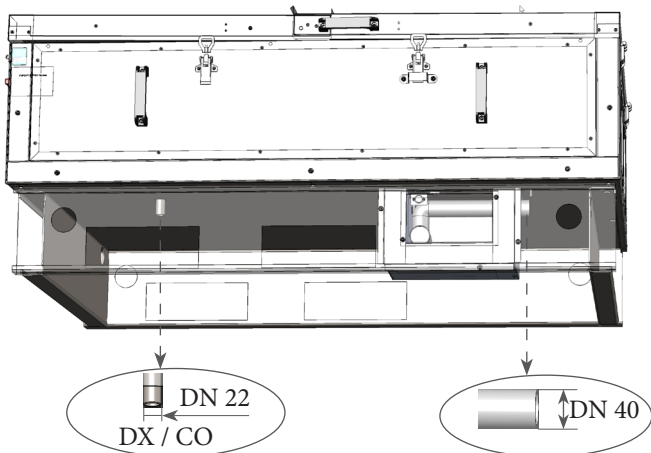

The connection to the condensate tray is located on the underside of the ventilation unit. Connect the drain pipe or hose to the condensate tray outlet .

- Make sure that the unit is tilted by 3°, this enables a free drainage of condensate.

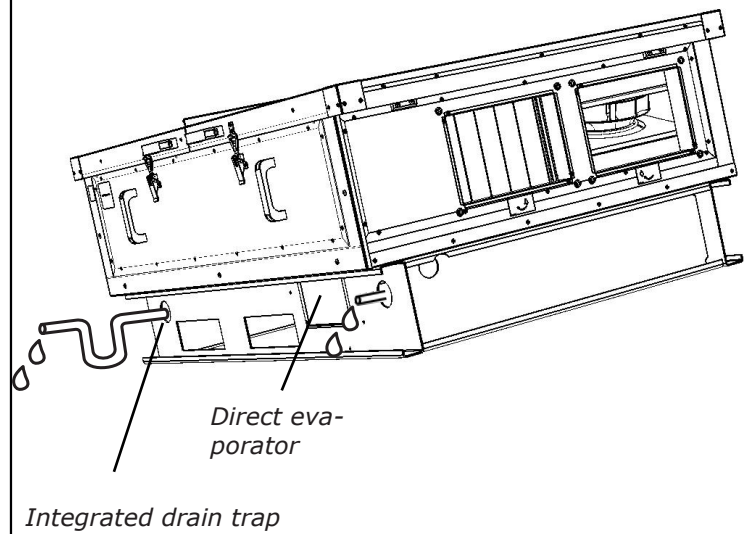
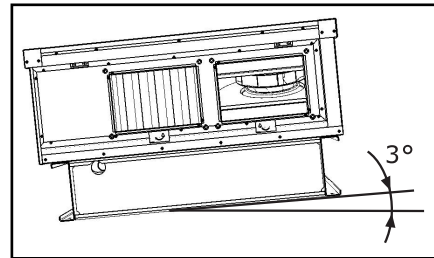

6. INSTALLATION

Optionally you can connect water overflow sensor (included in the package).



When the level of the condensate bath is exceeded, the sensor opens the contact, the unit switches to STANDBY mode an error will be signaled on the controller. When the contact is closed again, the unit returns to normal operation.

Open the service door and remove the heat exchanger.

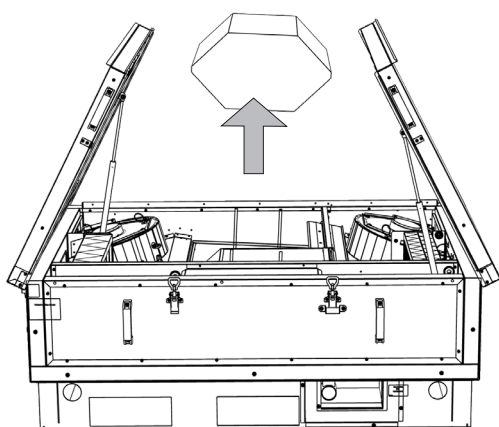

Connect the condensate overflow sensor to the bracket located in the condensate drain pan (see below).

Pass the cable from the swimmer through the hole with the temperature sensor and connect it to the regulation.

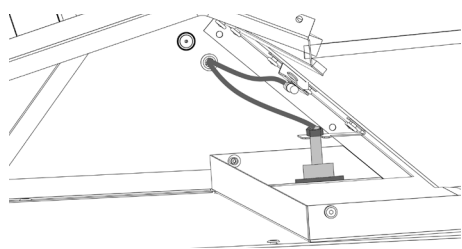
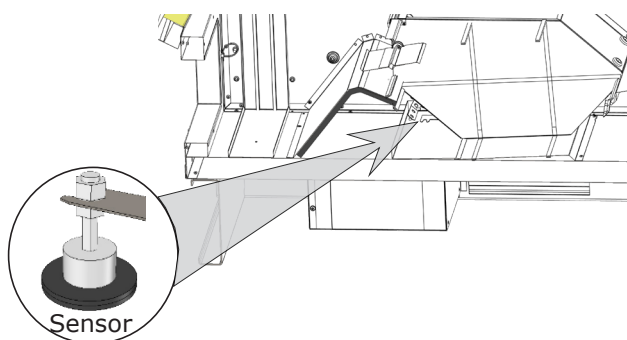

Connect the condensate overflow sensor to terminals 17, 18 on board B (see wiring diagram below).

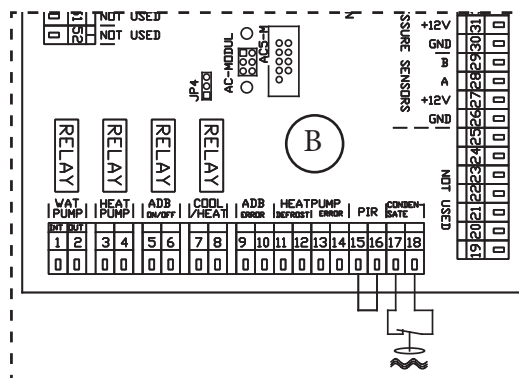

If the unit has a C-O exchanger or a DX exchanger, you can optionally connect another water overflow sensor to the condensating bath of the exchanger coil.

Connect the condensate overflow sensor to the bracket located in the condensate drain pan.

Connect the condensate overflow sensor to terminals 17, 18 on board B (see wiring diagram below).

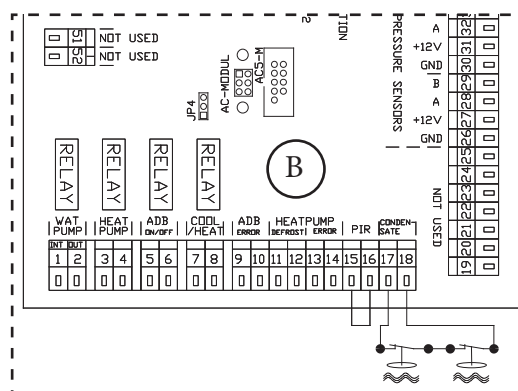

- Before putting the unit into operation, fill in the trap with water!!! Otherwise there is a risk of flooding and damage to the unit.

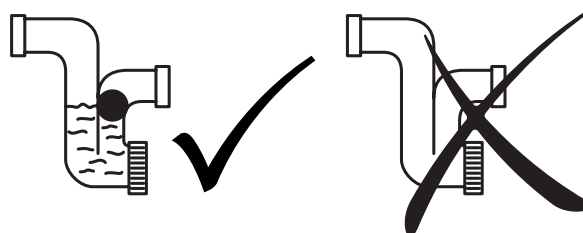

7. COMMISSIONING

READ CAREFULLY

Please check the following points before putting the unit into operation:

- *That the unit is fixed well to the supporting structure.*
- *That the unit is closed correctly and that a pipe or a rain louvre is installed to each neck to avoid contact with any rotating or heating component.*
- *That the electrical wiring is connected correctly, including grounding and protection against external activation.*
- *That all accessories are connected correctly.*
- *That the condensate drain is connected correctly to the discharge piping (for units with cooling).*
- *That the connection is in compliance with instructions in this manual.*
- *That no tool or other subject has been left inside the unit – this could lead to damage to the unit*

ATTENTION!

- *Any interventions or modifications to unit wiring are prohibited and may lead to loss of warranty!*
- *We recommend to use accessories supplied by our company. If in doubt whether to use unoriginal accessories, please contact 2VV.*

8. MAINTENANCE

8.1 REPLACING A FILTER

It is recommended to perform a visual inspection of the filter at least once every 3 months

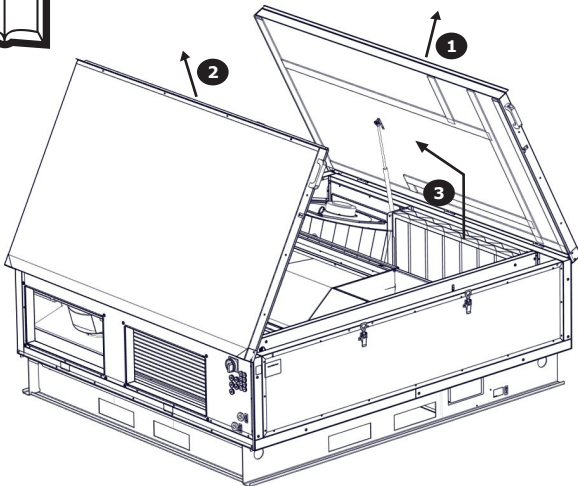

- 1) Open the top cover
- 2) Remove side panels
- 3) Pull out filters
- 4) Insert new filters, mount side panels, and close the top cover

Unit type	Filters	
	G4	Pre-filter G4
HR95-080..-.-.-.-	FILTR-HR95-2-H0800-G4	FILTR-HR95-2-H0800-G4-PRE
HR95-150..-.-.-.-	FILTR-HR95-2-H1500-G4	FILTR-HR95-2-H1500-G4-PRE
HR95-250..-.-.-.-	FILTR-HR95-2-H2500-G4	FILTR-HR95-2-H2500-G4-PRE
HR95-350..-.-.-.-	FILTR-HR95-2-H3500-G4	FILTR-HR95-2-H3500-G4-PRE

Unit type	F7
HR95-080..-.-.-.-	FILTR-HR95-2-H0800-F7-MPP
HR95-150..-.-.-.-	FILTR-HR95-2-H1500-F7-MPP
HR95-250..-.-.-.-	FILTR-HR95-2-H2500-F7-MPP
HR95-350..-.-.-.-	FILTR-HR95-2-H3500-F7-MP

READ CAREFULLY!
 • Warning icon will automatically disappear

ATTENTION!

Unit's performance may be reduced and the fan can be damaged if the filter is not properly cleaned or replaced.

8.2 CLEANING INTERVALS

YOU WILL NEED

- **3mm Allen wrench**
- **vacuum cleaner**
- **brush**
- **cloth**
- **neutral cleaning agent (soap water)**

It is recommended to check and clean the unit every six months; however, the intervals must be adapted to specific operating conditions. It is recommended to thoroughly clean the unit once a year.

If the unit is not in use for a long time, it is recommended to turn it on for about an hour every six months.

Follow the same procedure as when replacing the filter, see the previous chapter (8.1)

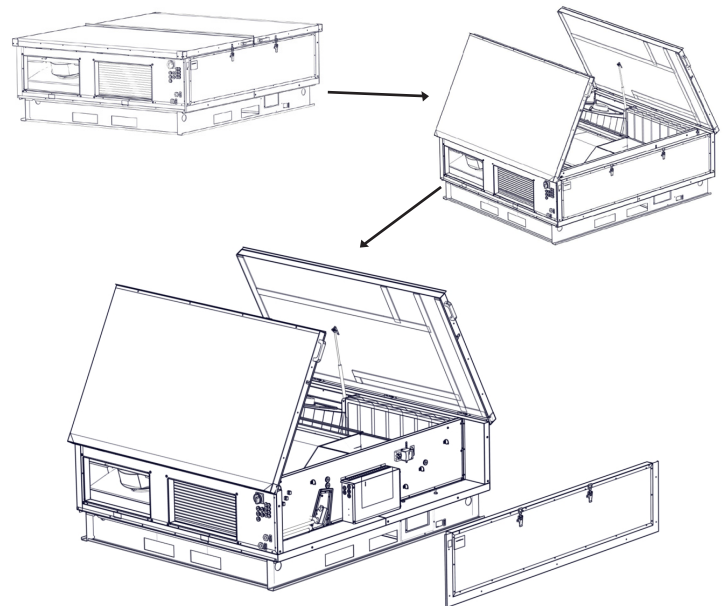

Clean the ventilation unit with a vacuum cleaner, brush, and cloth and soap water. Do not use sharp objects, aggressive chemicals, solvents, abrasive cleaners, high pressure washers, compressed air, steam.

9. REMOVING FAULTS

ATTENTION!

- Before starting the maintenance and repair works, the unit must be disconnected from the power source and the supply voltage must be locked, service switch must be in the position 0 (off).
- Do not start repairs, if you are not sure of or familiar with the exact procedure. Contact the specialised service!!!

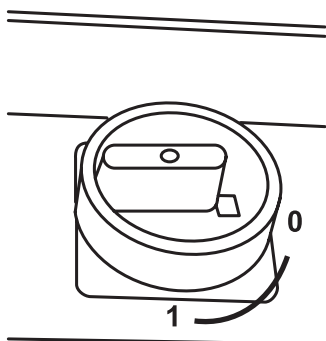

TECHNICAL DATA

- A fault is usually indicated by a message on the display, see the table below.

Description	Unit's behaviour	Likely problem	Solution
4 – Supply fan error	Unit is not working	Overheated fan or defect on thermal contact of inlet fan	Determine the cause of the overheating (defective bearing, short-circuit...) or replace the engine.
5 – Exhaust fan error	Unit is not working	Overheated fan or defect on thermal contact of inlet fan	Determine the cause of the overheating (defective bearing, short-circuit...) or replace the engine.
6 – Inlet filter clogged	Unit is ventilating	Clogged filter	Check the condition of the filter, or replace it. If the unit does not have a pressure sensor for the filter, RESET the clogged filter according to the manual.
7 – Exhaust filter clogged	Unit is ventilating	Clogged filter	Check the condition of the filter, or replace it. If the unit does not have a pressure sensor for the filter, RESET the clogged filter according to the manual.
8 - Failure in preheating 1	Unit is ventilating	Overheated electric exchanger or damaged sensor Open the exchanger thermostat.	Check that air can flow freely through the unit, electric heat exchanger is not cooling sufficiently. Check the safety thermostat on the electric preheating for damages.
9 - Failure in exchanger 1	Unit is ventilating	Overheated electric exchanger or damaged sensor Open the exchanger thermostat.	Check that air can flow freely through the unit, electric heat exchanger is not cooling sufficiently. Check the safety thermostat on the electric reheating for damages.
10 - Failure in exchanger 2	Unit is ventilating	Overheated electric exchanger or damaged sensor Open the exchanger thermostat.	Check that air can flow freely through the unit, electric heat exchanger is not cooling sufficiently. Check the safety thermostat on the electric reheating for damages.
11 - Failure in preheating 1	Unit is ventilating	Overheated electric exchanger or damaged sensor Open the exchanger thermostat.	Check that air can flow freely through the unit, electric heat exchanger is not cooling sufficiently. Check the safety thermostat on the electric preheating for damages.

9. REMOVING FAULTS

Description	Unit's behaviour	Likely problem	Solution
12 - CO2 sensor failure	Unit is ventilating	Defective air quality sensor	Check that the CO2 sensor is connected correctly or check that it is operating correctly (output signal value)
13 - Failure of rotary heat exchanger	Unit is not working	Failure of rotary heat exchanger	Check that the input error is correctly connected to the electronics or check what type of error the heat exchanger is indicating.
14 - ADB module error	Unit is ventilating	Failure of adiabatic module	Check that the input error is correctly connected to the electronics or, if necessary, that the adiabatic module is operating correctly
15 - Heat pump error	Unit is ventilating	Heat pump failure	Check that the input error is correctly connected to the electronics or, if necessary, that the heat pump is operating correctly (according to the instructions of its manufacturer)
16 - Inlet - External temperature sensor failure (T-EXT1)	Unit is not working	Room temperature sensor failure	Check that the sensor is correctly connected to the electronics or test it measuring its resistance (the resistance value at +20°C is around 10kΩ)
17 - Inlet - Failure of the temperature sensor behind the exchanger (T-EXT2)	Unit is not working	Room temperature sensor failure	Check that the sensor is correctly connected to the electronics or test it measuring its resistance (the resistance value at +20°C is around 10kΩ)
18 - Inlet - Temperature sensor failure in the supply canal (T-EXT3)	Unit is not working	Room temperature sensor failure	Check that the sensor is correctly connected to the electronics or test it measuring its resistance (the resistance value at +20°C is around 10kΩ)
19 - Inlet - Temperature sensor failure after the second exchanger (T-EXT4)	Unit is not working	Room temperature sensor failure	Check that the sensor is correctly connected to the electronics or test it measuring its resistance (the resistance value at +20°C is around 10kΩ)
20 - Exhaust - Temperature sensor failure in the exhaust canal (T-INT0)	Unit is not working	Room temperature sensor failure	Check that the sensor is correctly connected to the electronics or test it measuring its resistance (the resistance value at +20°C is around 10kΩ)
21 - Exhaust - Temperature sensor failure in the exhaust canal (T-INT1)	Unit is not working	Room temperature sensor failure	Check that the sensor is correctly connected to the electronics or test it measuring its resistance (the resistance value at +20°C is around 10kΩ)

9. REMOVING FAULTS

Description	Unit's behaviour	Likely problem	Solution
22 – Exhaust – Failure of the temperature sensor of the exchanger's anti-freeze protection (T-INT2)	Unit is not working	Room temperature sensor failure	Check that the sensor is correctly connected to the electronics or test it measuring its resistance (the resistance value at +20°C is around 10kW)
23 - Temperature sensor failure of the exchanger's water supply (T_WATER_IN)	Unit is not working	Room temperature sensor failure	Check that the sensor is correctly connected to the electronics or test it measuring its resistance (the resistance value at +20°C is around 10kW)
24 - Failure in the return water sensor of exchanger (T_WATER_OUT)	Unit is not working	Room temperature sensor failure	Check that the sensor is correctly connected to the electronics or test it measuring its resistance (the resistance value at +20°C is around 10kW)
25 – Room temperature sensor failure (T_Room)	Unit is ventilating	Room temperature sensor failure	Check that the sensor is correctly connected to the electronics or test it measuring its resistance (the resistance value at +20°C is around 10kW)
26 - Failure in the pressure sensor of the exhaust filter.	Unit is ventilating	Pressure sensor failure	Check the supply point for mechanical damage or whether it is clogged by dirt, or whether the supply hoses are free. The pressure sensor will likely need to be replaced
27 - Failure in the pressure sensor of the inlet filter	Unit is ventilating	Pressure sensor failure	Check the supply point for mechanical damage or whether it is clogged by dirt, or whether the supply hoses are free. The pressure sensor will likely need to be replaced
28 - Failure in the pressure sensor of the inlet fan	Unit is not working correctly	Pressure sensor failure	Check the supply point for mechanical damage or whether it is clogged by dirt, or whether the supply hoses are free. The pressure sensor will likely need to be replaced
29 - Failure in the pressure sensor of the exhaust fan	Unit is not working correctly	Pressure sensor failure	Check the supply point for mechanical damage or whether it is clogged by dirt, or whether the supply hoses are free. The pressure sensor will likely need to be replaced
30 - Failure in the pressure sensor of the VAV supply channel	Unit is not working correctly	Pressure sensor failure	Check the supply point for mechanical damage or whether it is clogged by dirt, or whether the supply hoses are free. The pressure sensor will likely need to be replaced
31 - Failure in the pressure sensor of the VAV C4 exhaust channel	Unit is not working correctly	Pressure sensor failure	Check the supply point for mechanical damage or whether it is clogged by dirt, or whether the supply hoses are free. The pressure sensor will likely need to be replaced

9. REMOVING FAULTS

Description	Unit's behaviour	Likely problem	Solution
32 - Air quality sensor failure	Unit is ventilating	Defective air quality sensor	Check that the quality sensor is connected correctly or check that it is operating correctly (output signal value)
33 - Failure in the recirculation relative humidity sensor	Unit is ventilating	Defective relative humidity sensor	Check that the humidity sensor is connected correctly or check that it is operating correctly (output signal value)
34 - Failure in the sensor of external temperature from BMS	Unit is ventilating	Defective sensor in BMS or incorrectly received data	Check that the address and values of the sensor in the BMS system are correct. Check that the sensor in the BMS system is working.
35 - Failure in the REK antifreeze protection relative humidity sensor	The unit is ventilating the permission to use preheating	Defective relative humidity sensor	The communication cable to the relative humidity sensor is damaged or disconnected. The humidity has exceeded the permitted limit and the sensor may temporarily measure incorrect values. Check the connection of the sensor. Set its address Check that it is not flooded. Replace if necessary.
36 - B moduli error	Unit is not working	The unit can not control the peripherals connected to Module B	Unable to communicate with module B. Check whether the communication cable between motherboards A and B is damaged If necessary, replace module B
37 - Condensate pan overflow	Unit is not working	The level sensor has detected an extremely high level of water in the condenser's pan	Check that the level sensor is connected correctly or check that it is operating correctly, or whether the condensate drain is not clogged, preventing the condensate from draining correctly.
50 - Inlet filter clogged > 80%	Unit is ventilating	Clogged filter	Filter change recommended
51 - Exhaust filter clogged > 80%	Unit is ventilating	Clogged filter	Filter change recommended
70 - Anti-freeze protection of the water heat exchanger	Unit is ventilating	The anti-freeze protection of the water heat exchanger is active	The automatic protection of the water exchanger has been activated in order to prevent damages due to low air temperature. This is an autonomous function and will be terminated once the risk of frost disappears. f
71 - Water heater - waiting for water temperature	Unit is ventilating	The unit controls the temperature of the liquid in the exchanger	The automatic process that assess the water temperature in the exchanger to activate the next steps is in progress
72 - Water heater - waiting for supply air temperature	Unit is ventilating	The unit controls the temperature of the air flowing through the exchanger	The automatic process that assess the temperature of the air flowing through the exchanger to activate the next steps is in progress

9. REMOVING FAULTS

Description	Unit's behaviour	Likely problem	Solution
73 - WCO detects temperature of the water supply (cold / hot)	Unit is ventilating	The unit controls the temperature of the liquid in the exchanger	The automatic process that assess the water temperature in the exchanger to activate the next steps is in progress
73 - Pre-freecooling active	Unit is ventilating	Temperature evaluation for free-cooling mode in progress	Preparation for freecooling mode in progress. It evaluates the temperature and the conditions necessary to activate this mode.
74 - Flow reduction, minimum temperature in the canal not reached	Unit operates in a restricted mode	The unit is trying to reach the set values of the channel's minimum	The temperature of the air flowing into the inlet branch of the building has not been reached. The performance of the unit is being automatically corrected to reach this minimum level. Automatic process
75 - Passive house protection	Unit is not working	The unit is operating in order to meet the Passive house specifications	The temperature of the air flowing into the inlet branch of the building is not within the Passive House specifications. The performance of the unit is being automatically corrected to reach this minimum level. Automatic process
76 - Heat pump defrost	Unit operates in a restricted mode	The unit is waiting until the heat pump defrosts.	The heat pump is reporting that it is defrosting. The unit is operating in defrost-waiting mode Automatic process

Umístění pojistek

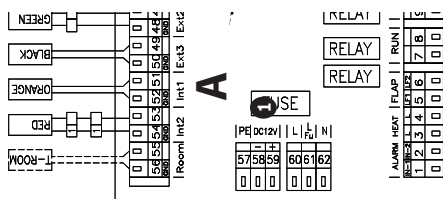

- 1 Umístění pojistek na elektronické desce:
T2A 5x20mm 250V
- 2 Pojistky motoru:
informace je umístěna na štítku vedle pojistky, nebo přímo na pojistce

ČTĚTE POZORNĚ!

- V případě výpadku proudu a následného obnovení síťového napětí se jednotka vrátí do stavu, v jakém byla před výpadkem. Jednotka si vždy pamatuje stav fungování i veškerá nastavení. Pokud se vám nedaří zjistit příčinu poruchy nebo ji odstranit nebo pokud oprava vyžaduje zásah do zařízení, obraťte se na autorizovaný servis.

10. SERVICE

10.1 IF THE FAULT PERSISTS

If you cannot remove the fault, please contact the supplier.

READ CAREFULLY!

- *Provide the following information to facilitate the fault removal:*
 - *Product type*
 - *Serial number*
 - *Operating time*
 - *Used accessories*
 - *Unit location*
 - *Connection conditions (including electrical conditions)*
 - *Detailed description of the fault and steps taken to remove it*

10.2 PUTTING THE PRODUCT OUT OF OPERATION – DISPOSAL

Please make the product inoperative before disposal. Older units also include reusable materials. Take them to the waste separation site.

The product should be dismantled in a specialised centre so that the recyclable materials can be reused. Parts that cannot be recycled in should be taken to a legal waste disposal site.

Materials must be disposed of in accordance with applicable national regulations and directives.

11. WIRING DIAGRAM

unit with electric exchanger / unit without electric exchanger with external water exchanger

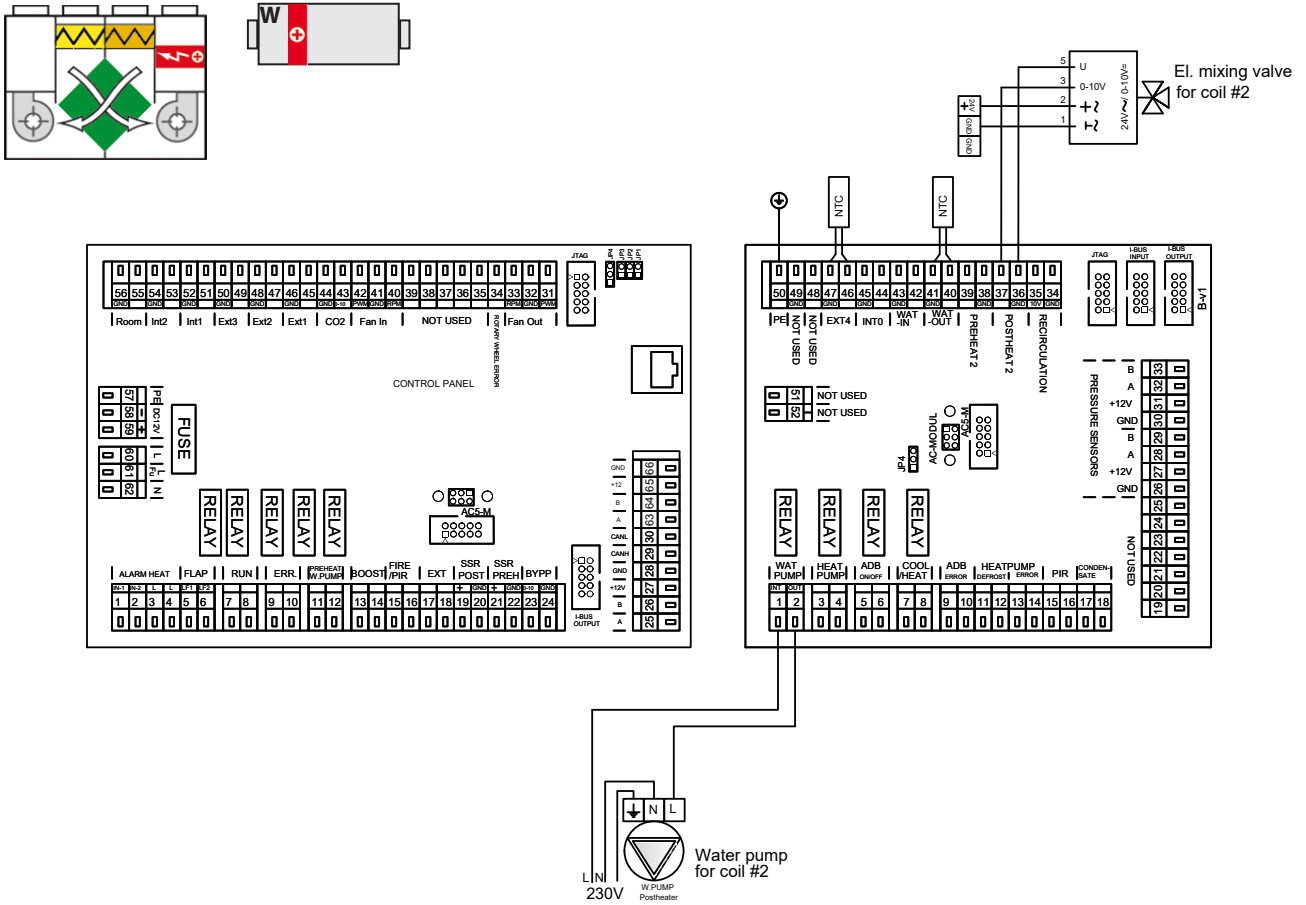

unit with electric exchanger / unit without electric exchanger with external electric exchanger

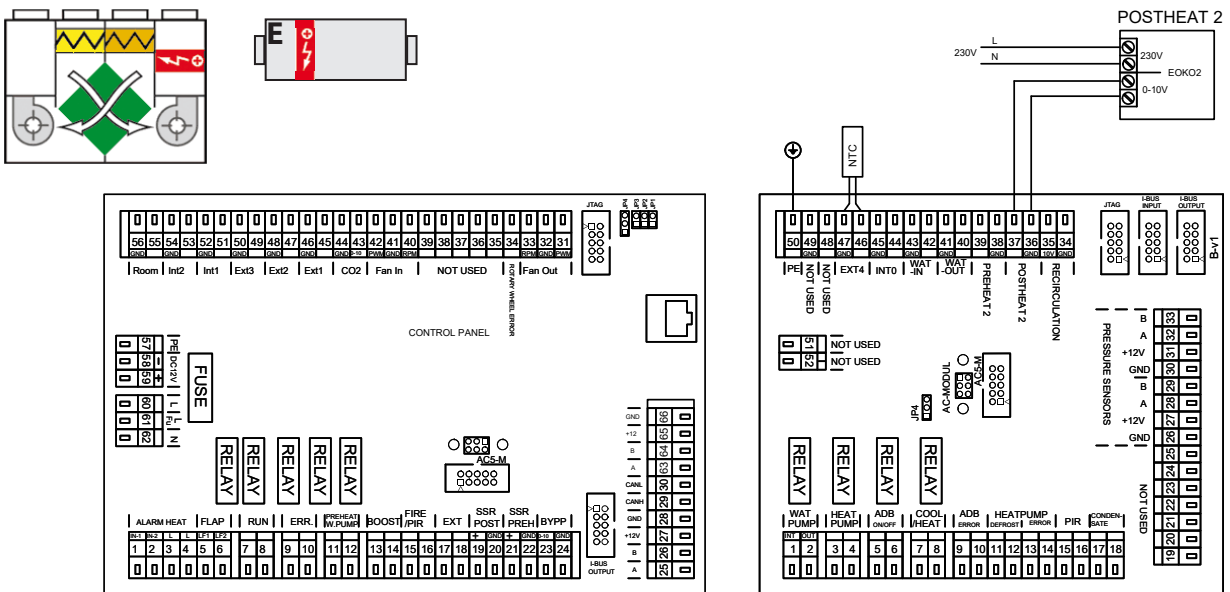

11. WIRING DIAGRAM

unit with electric exchanger / unit without electric exchanger with external C-O exchanger

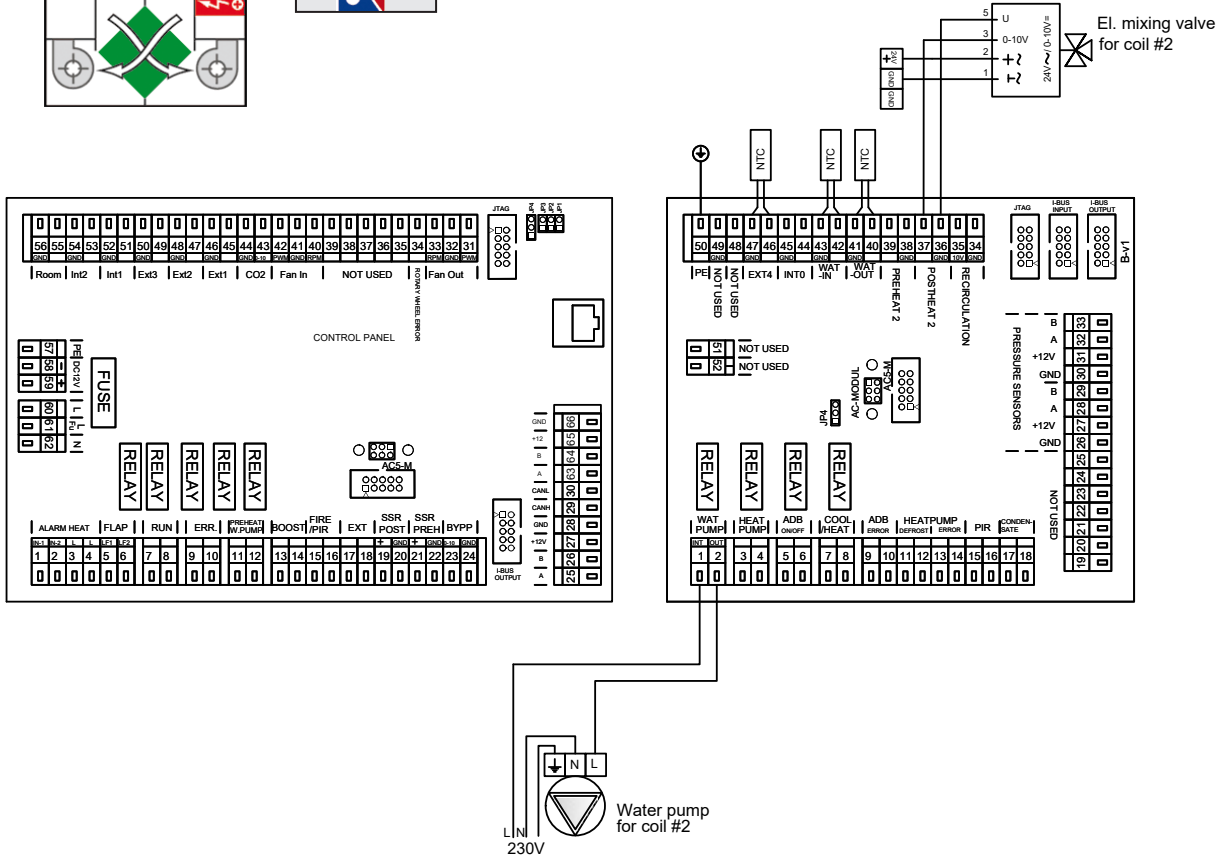
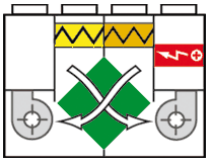

unit with electrical exchanger and second external DX exchanger with OFF / ON control

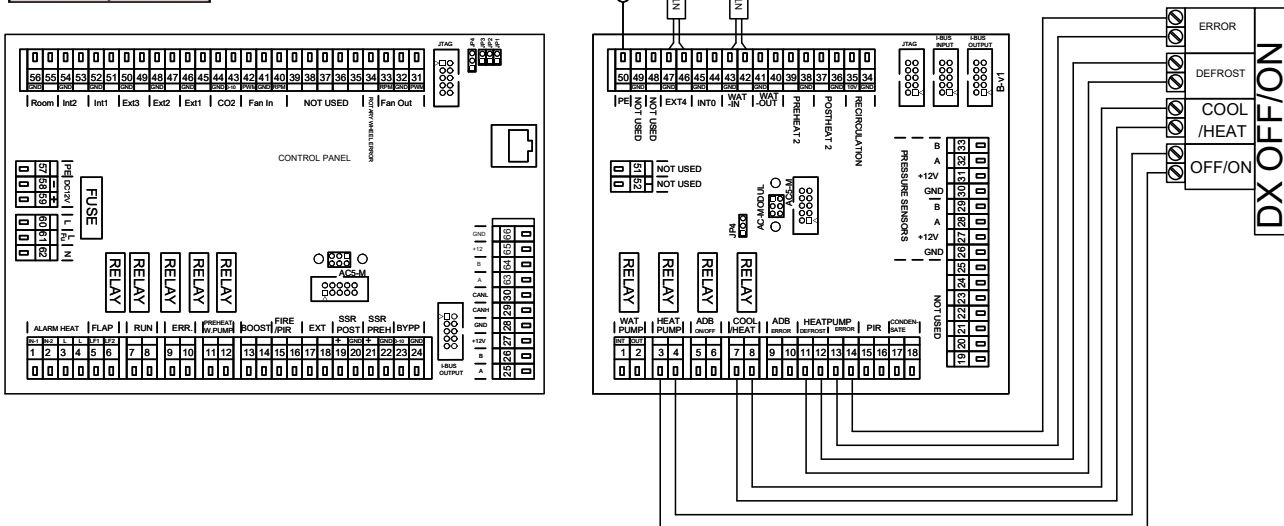
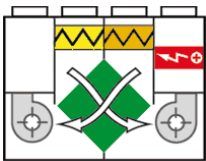

11. WIRING DIAGRAM

unit with electrical exchanger and second external DX exchanger with 0-10V control

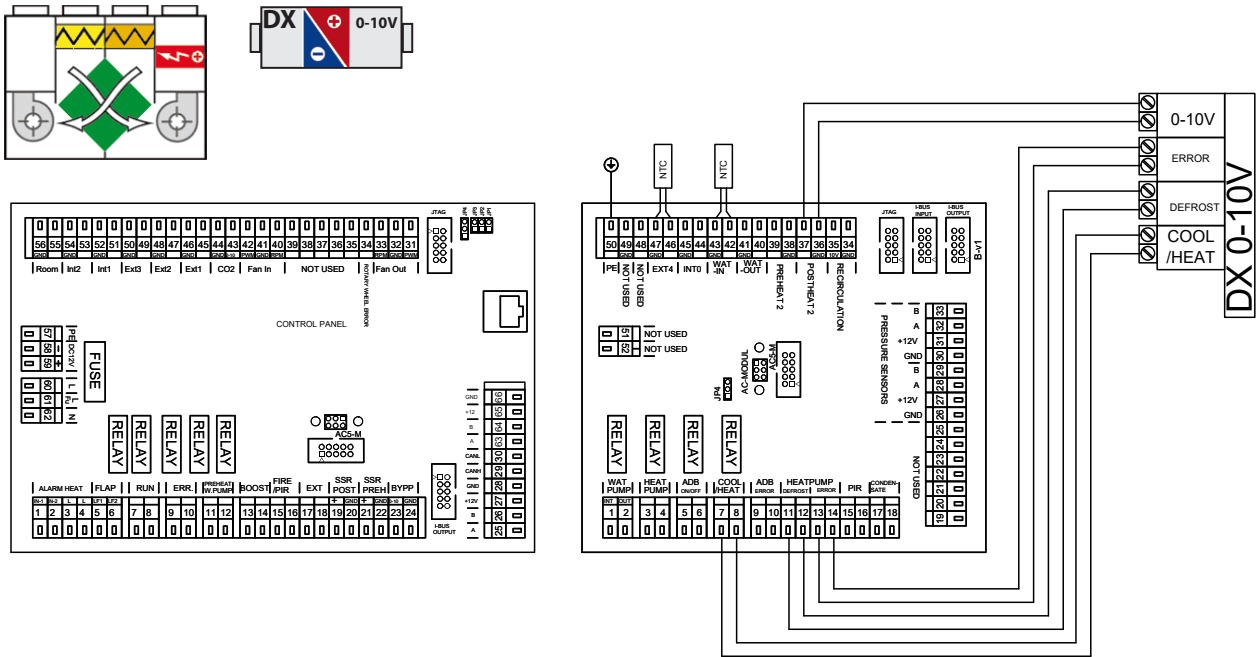

unit with water exchanger

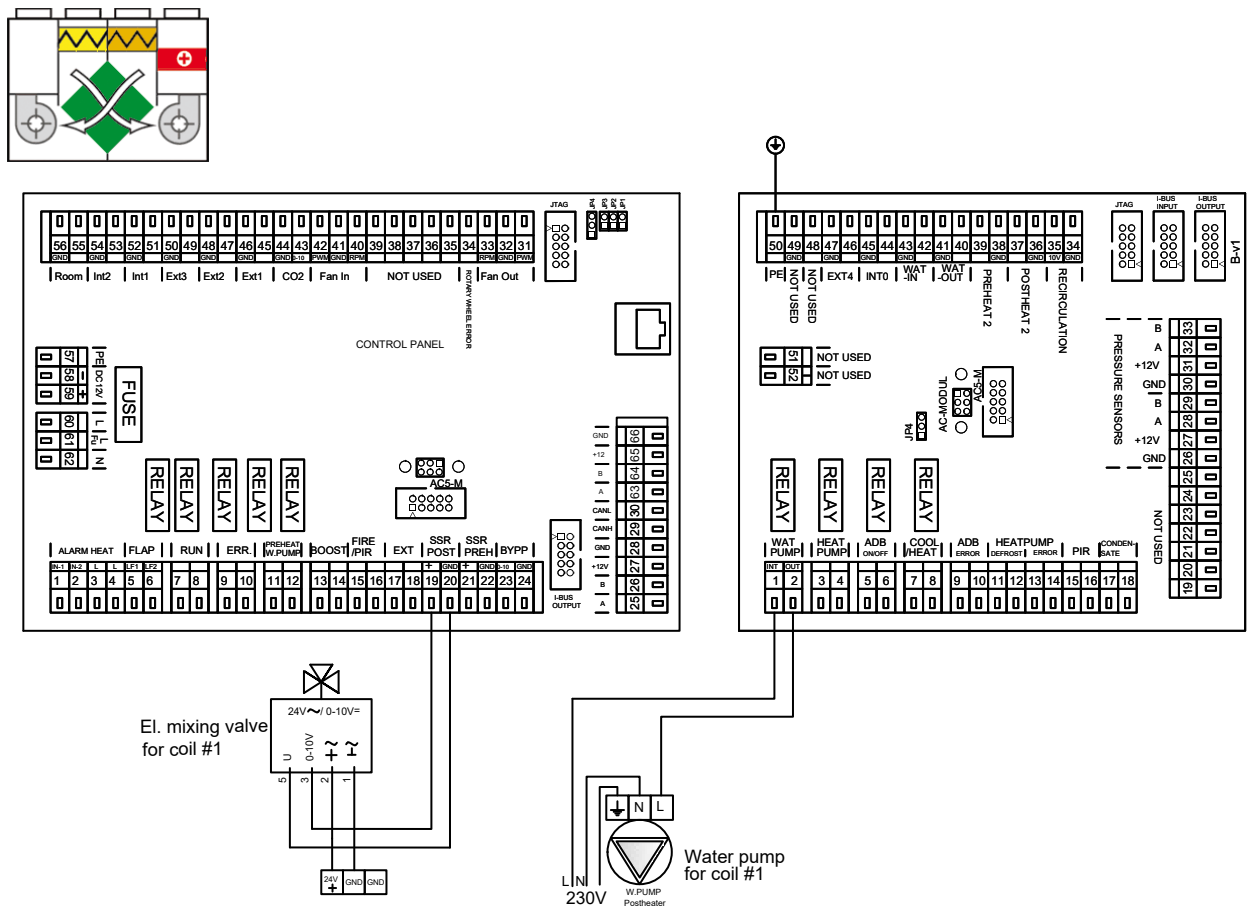

11. WIRING DIAGRAM

unit with water exchanger and second water external exchanger for water cooling

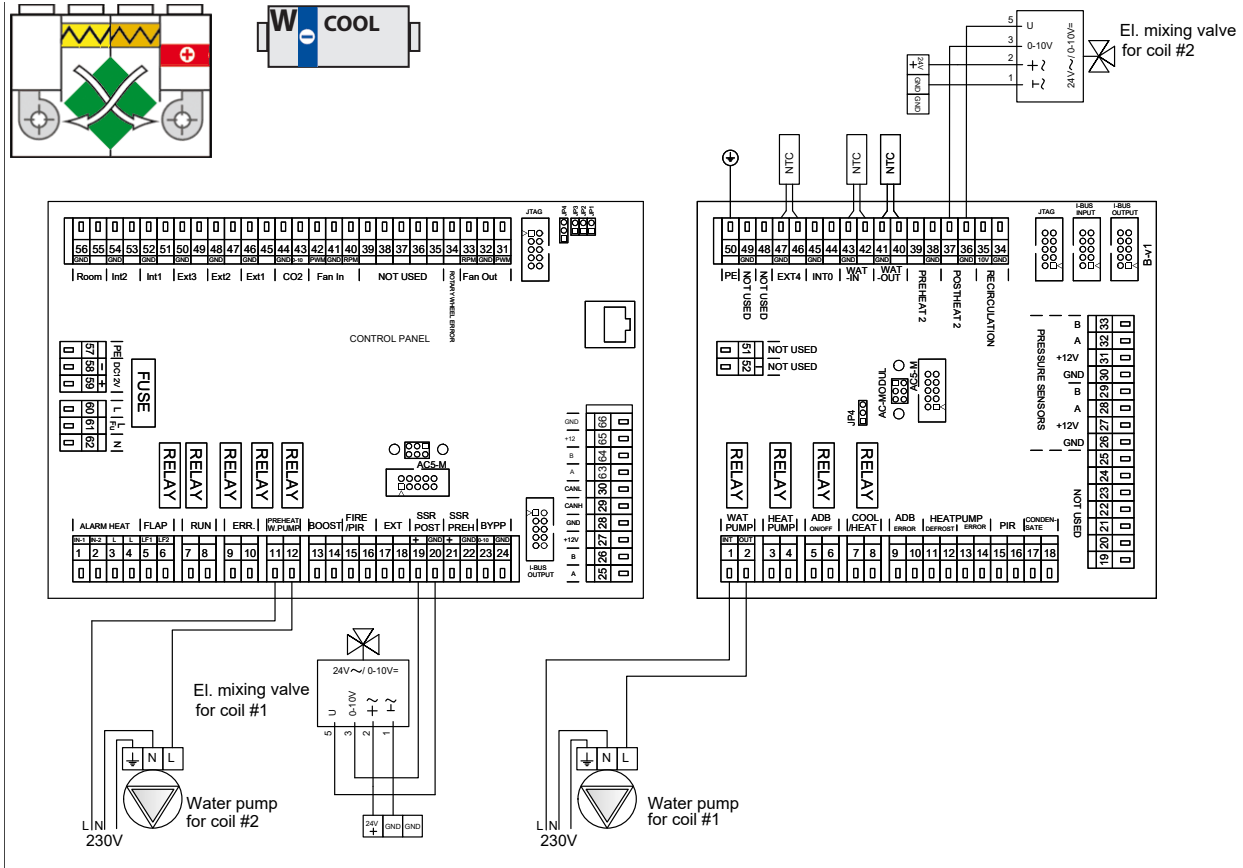

unit with water exchanger and second external electric exchanger

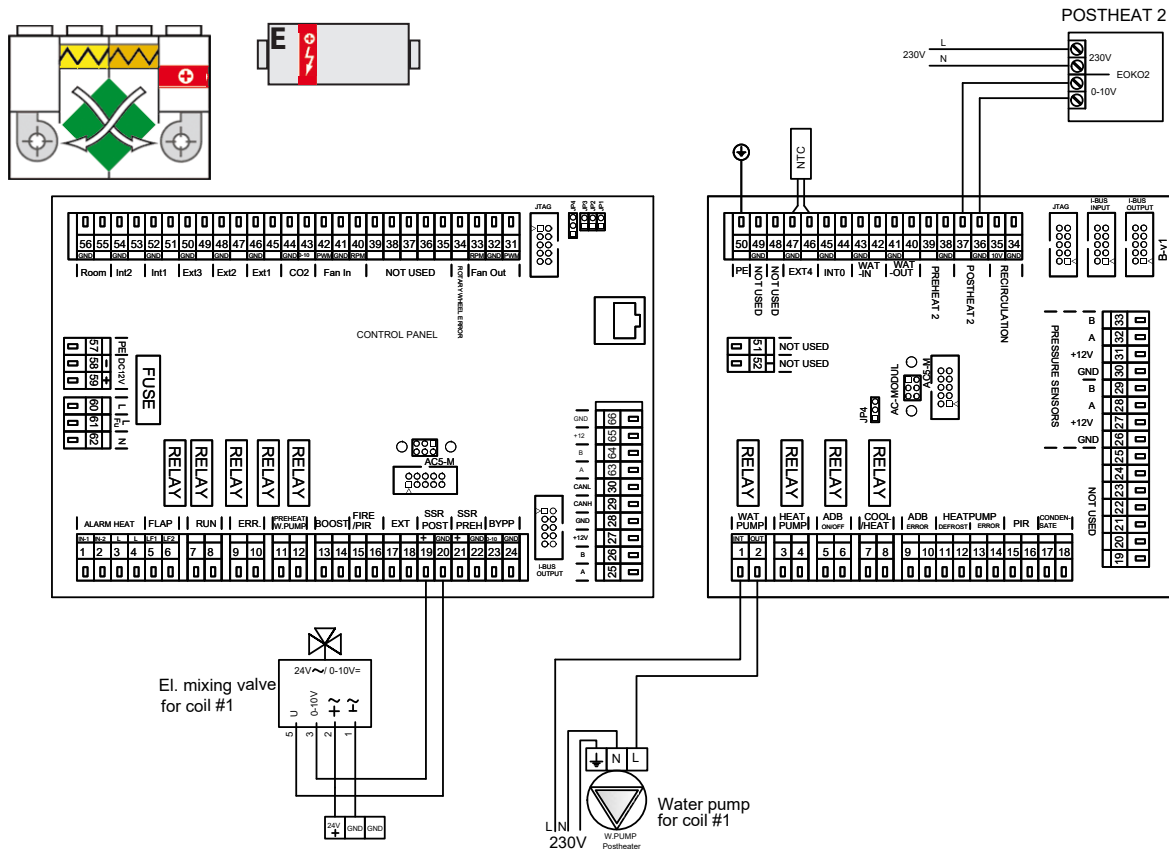

11. WIRING DIAGRAM

unit with water exchanger and second external DX exchanger with OFF / ON control

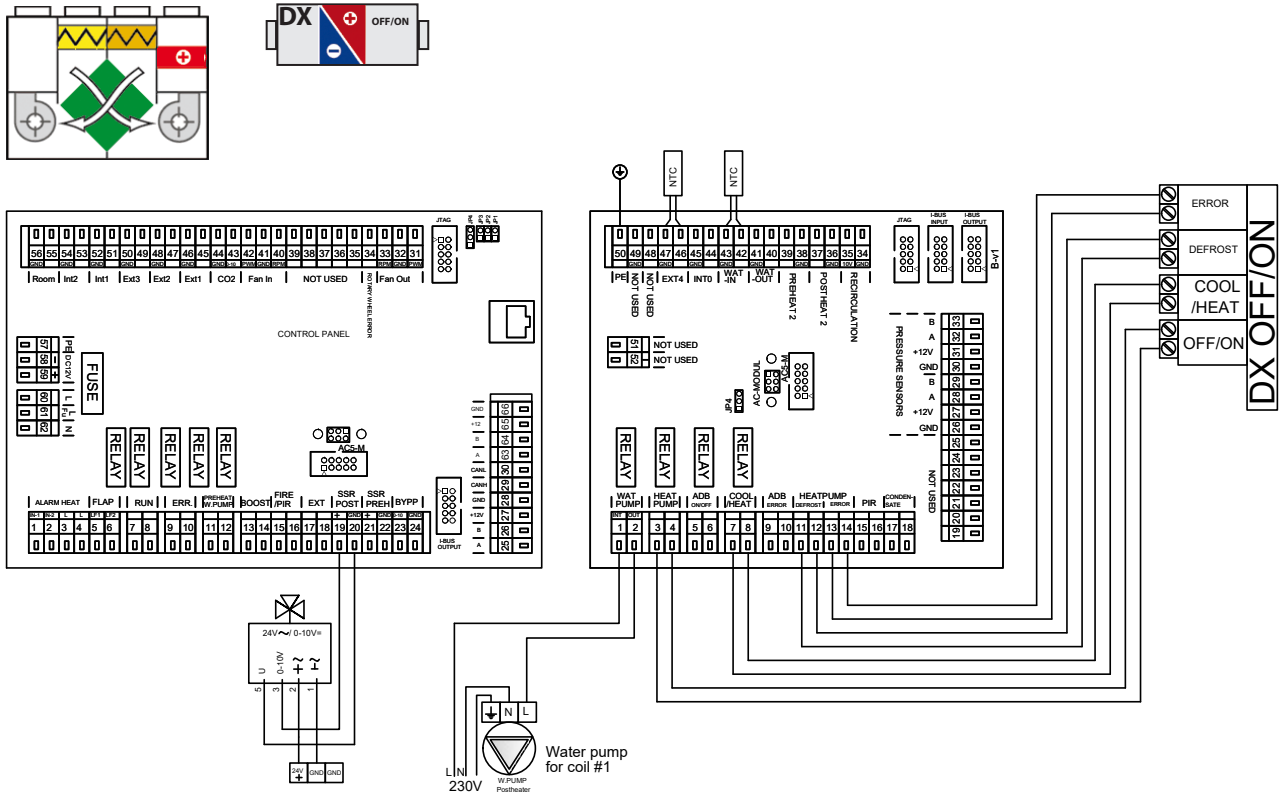

unit with water exchanger and second external DX exchanger with 0-10V control

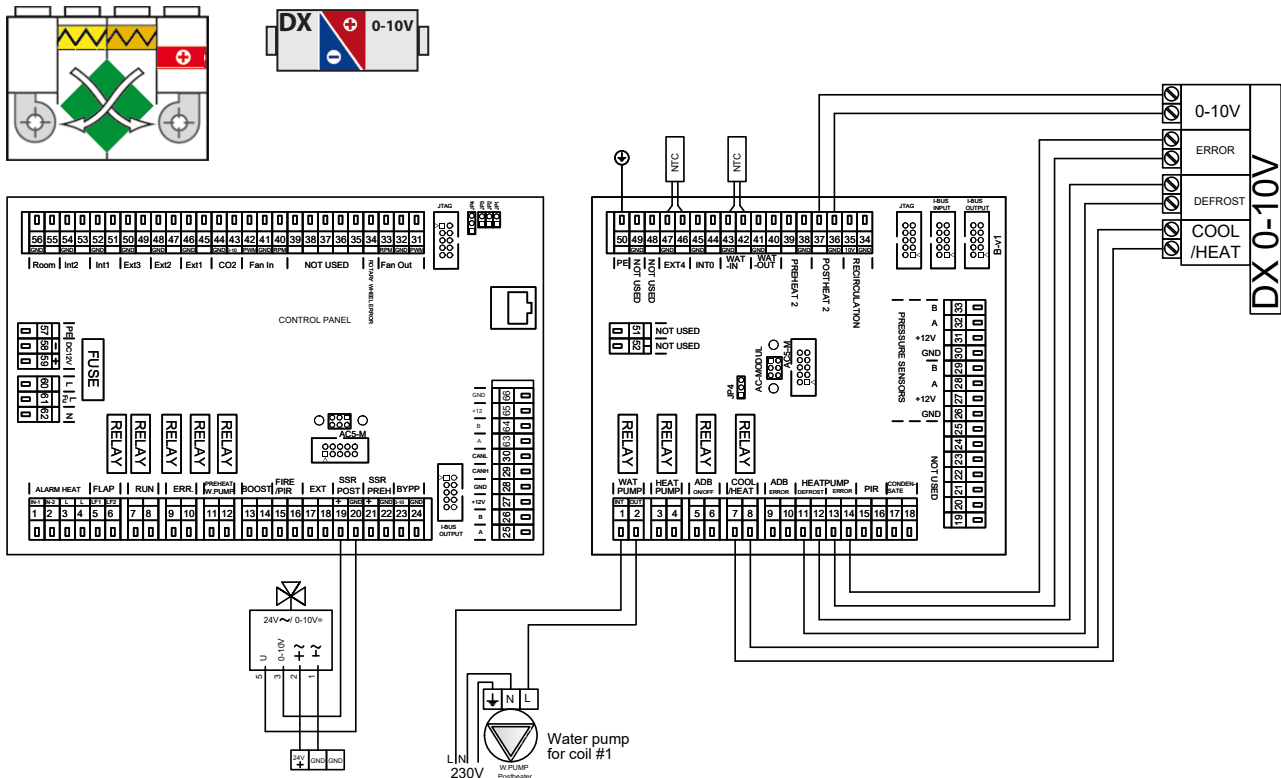

11. WIRING DIAGRAM

unit with DX 0-10V exchanger

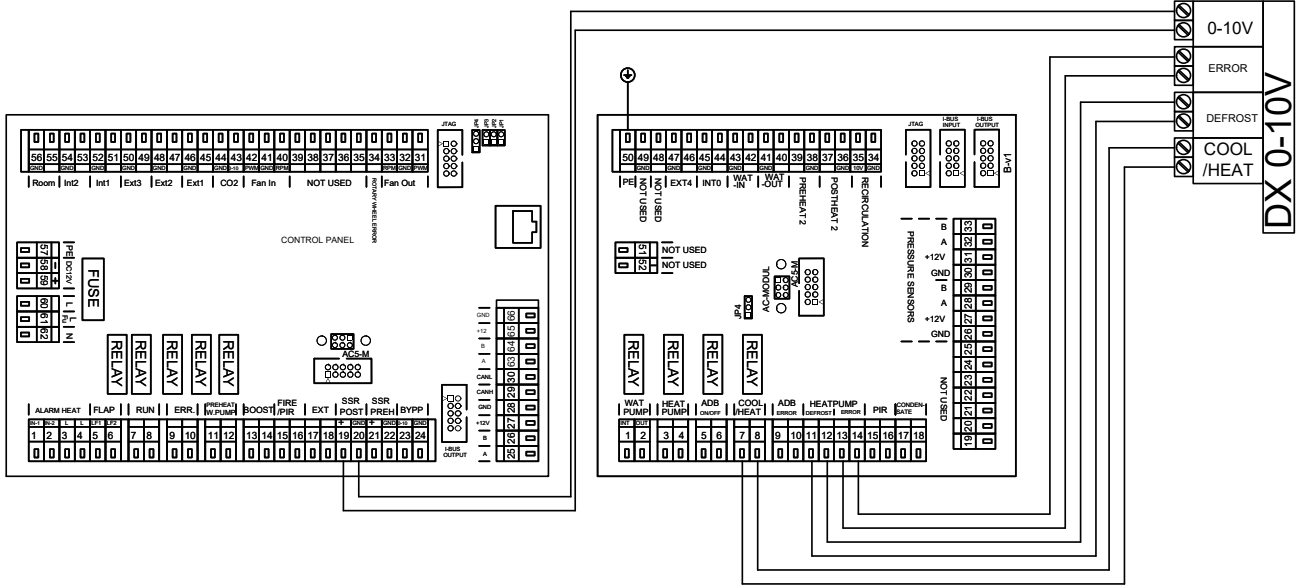
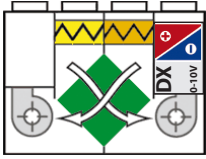

unit with DX exchanger control OFF/ON

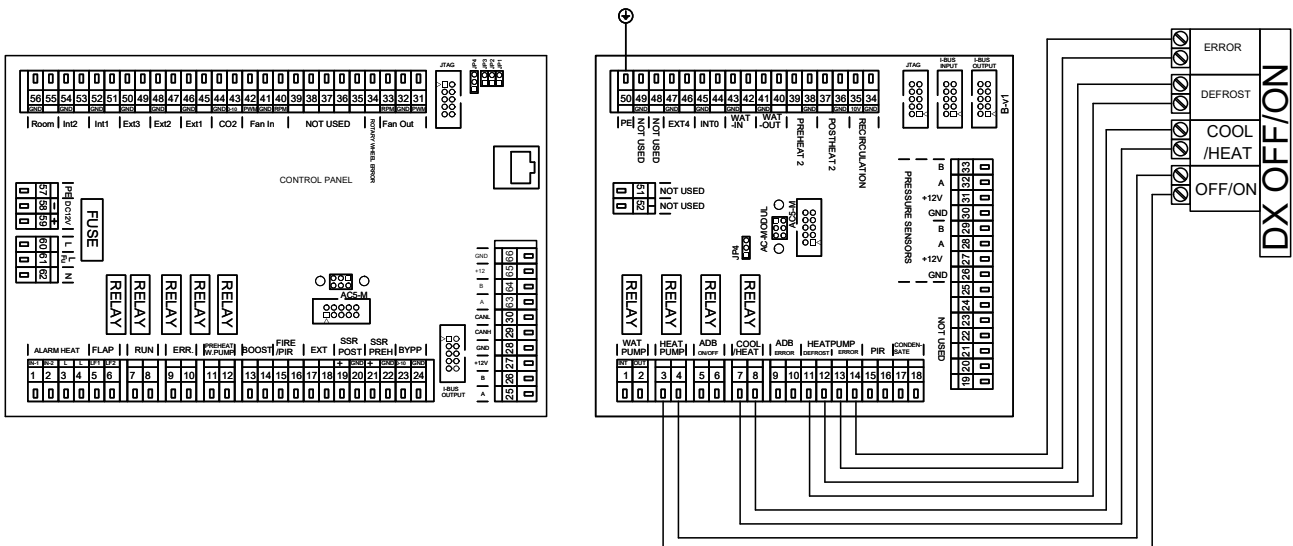
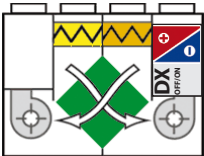

11. WIRING DIAGRAM

unit with DX exchanger, control OFF/ON and second external electric exchanger

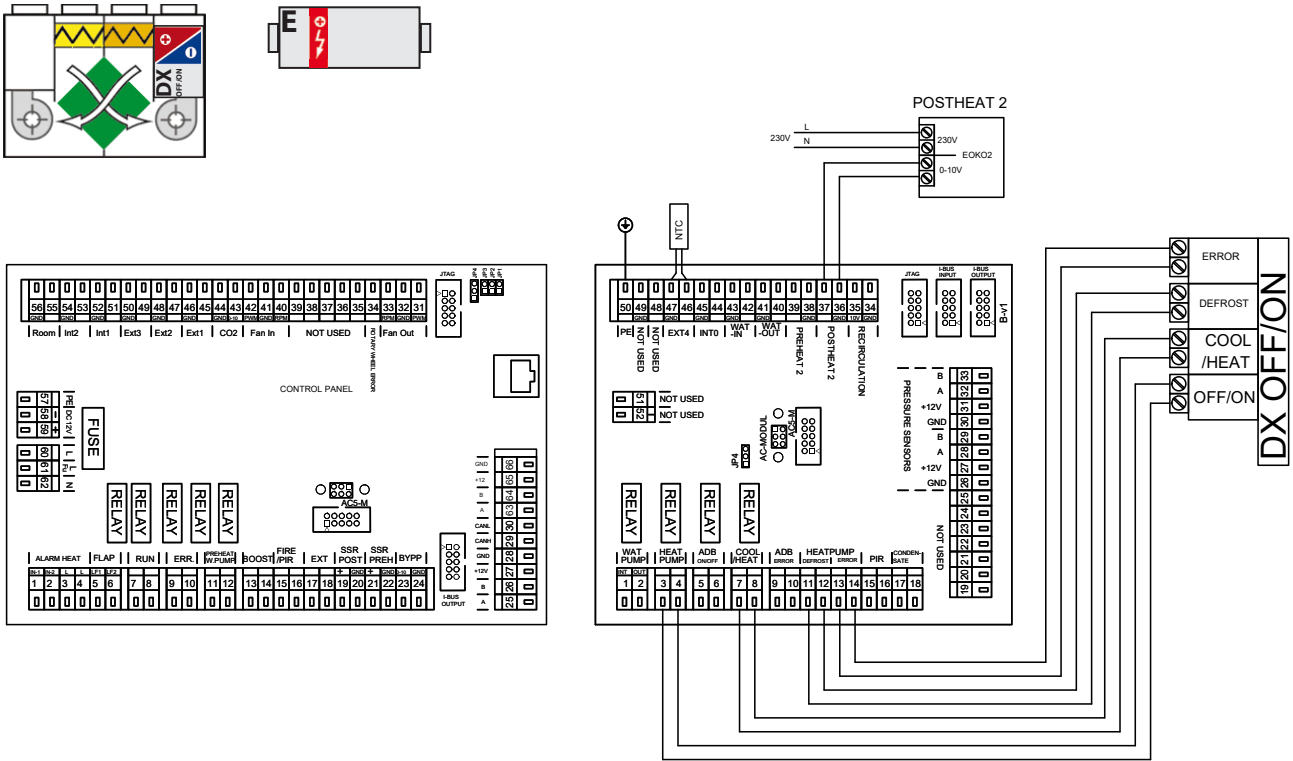

unit with DX exchanger control 0-10V and second external electric exchanger

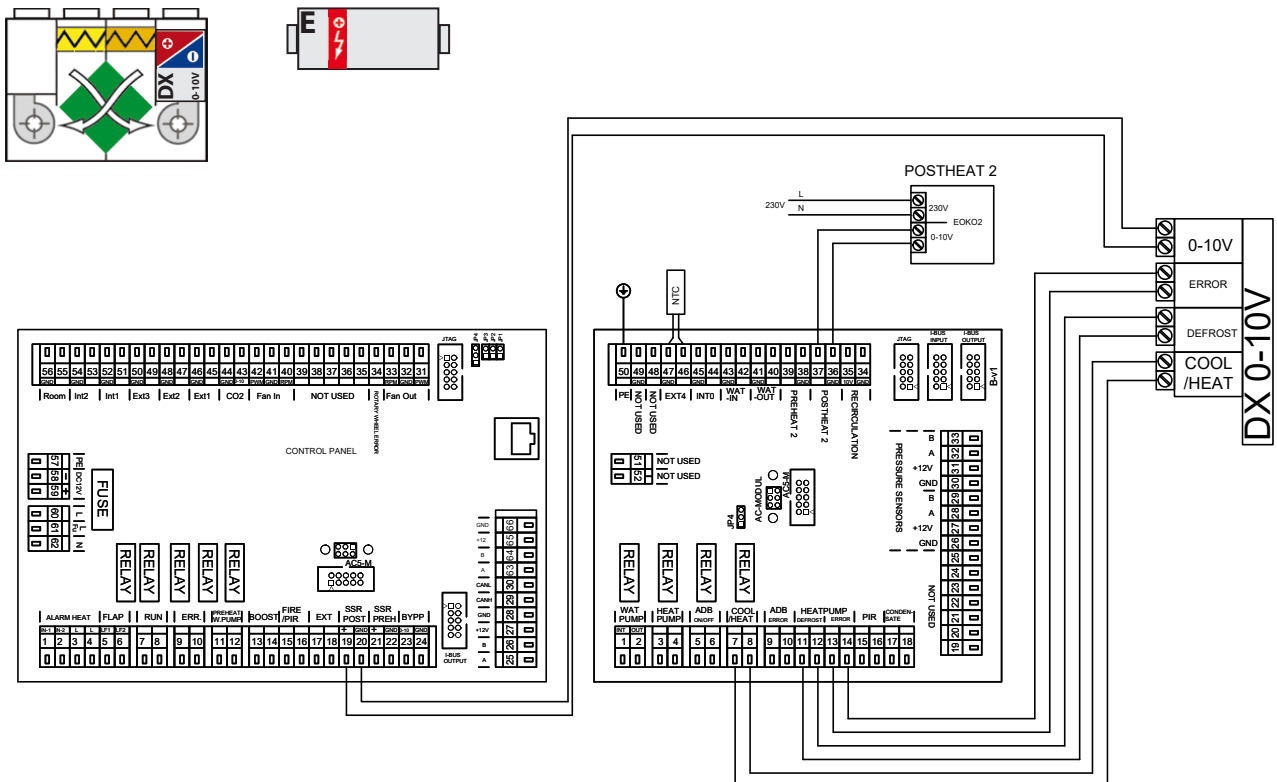

11. WIRING DIAGRAM

unit with DX exchanger control OFF/ON and second external water exchanger

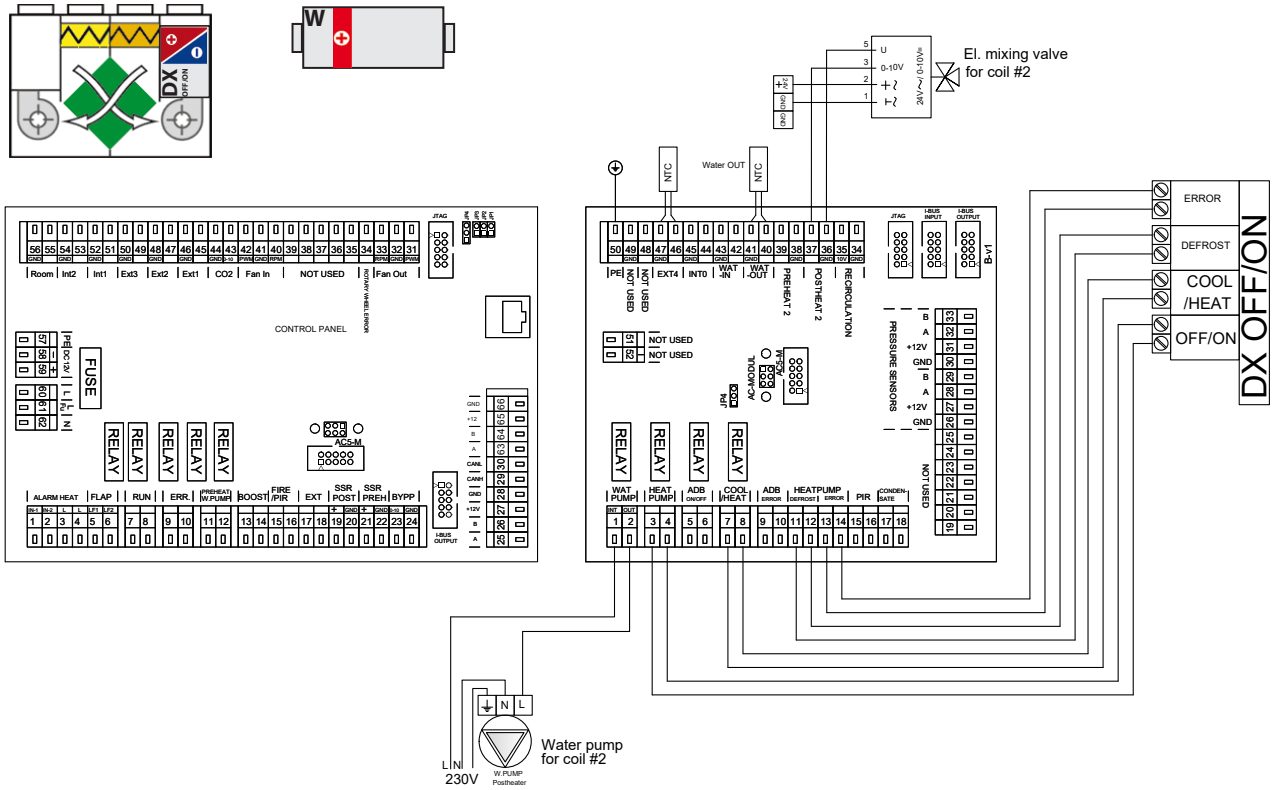

unit with DX exchanger control 0-10V and second external water exchanger

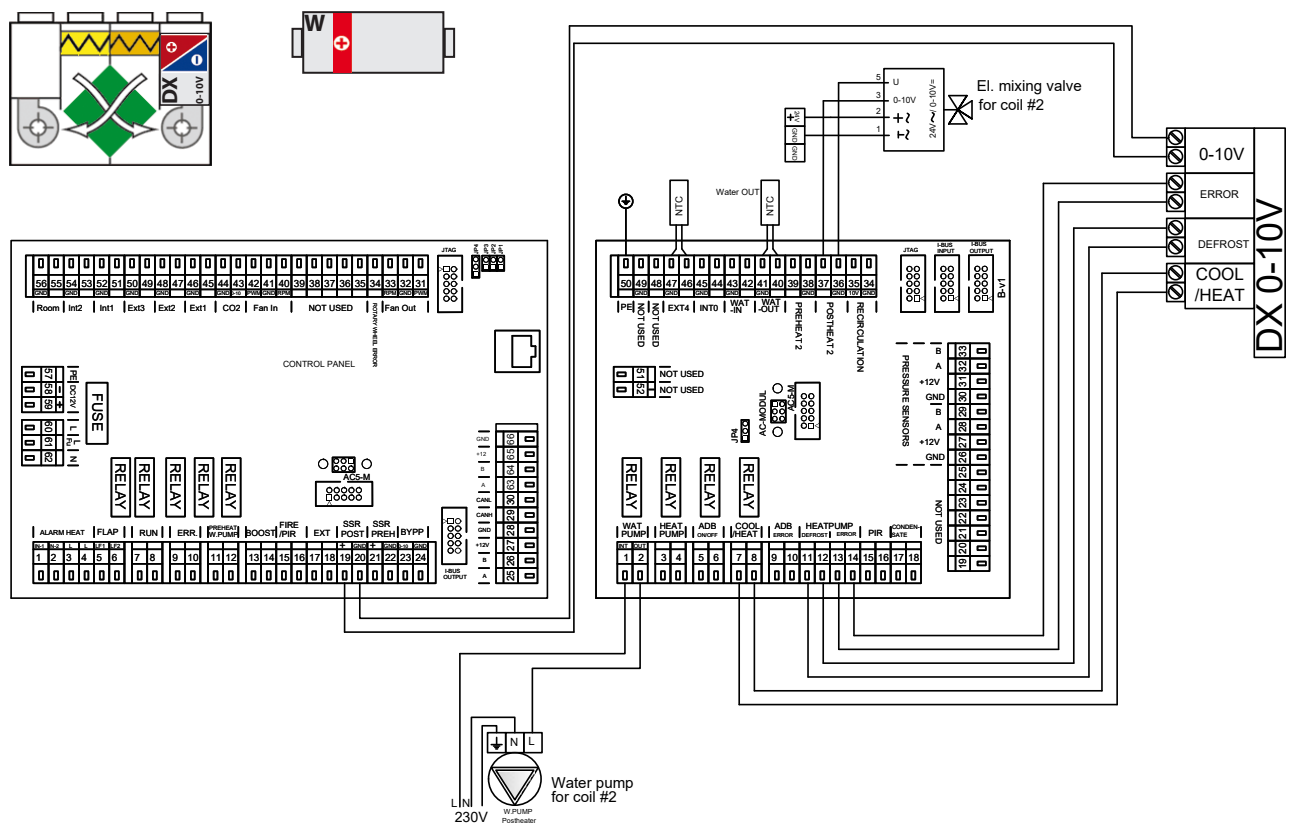

11. WIRING DIAGRAM

unit with exchanger for heating / cooling and second external electric exchanger

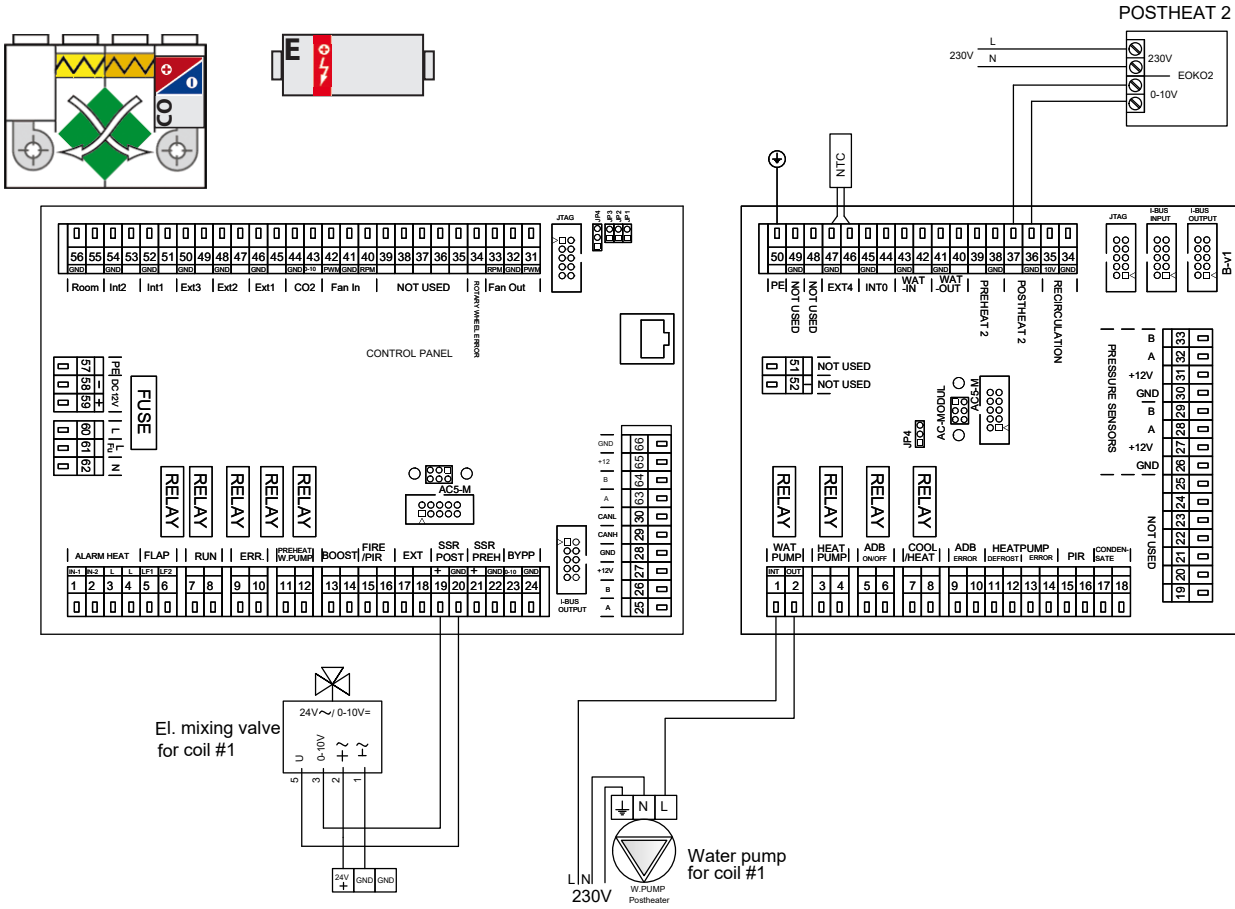

unit with exchanger for heating / cooling

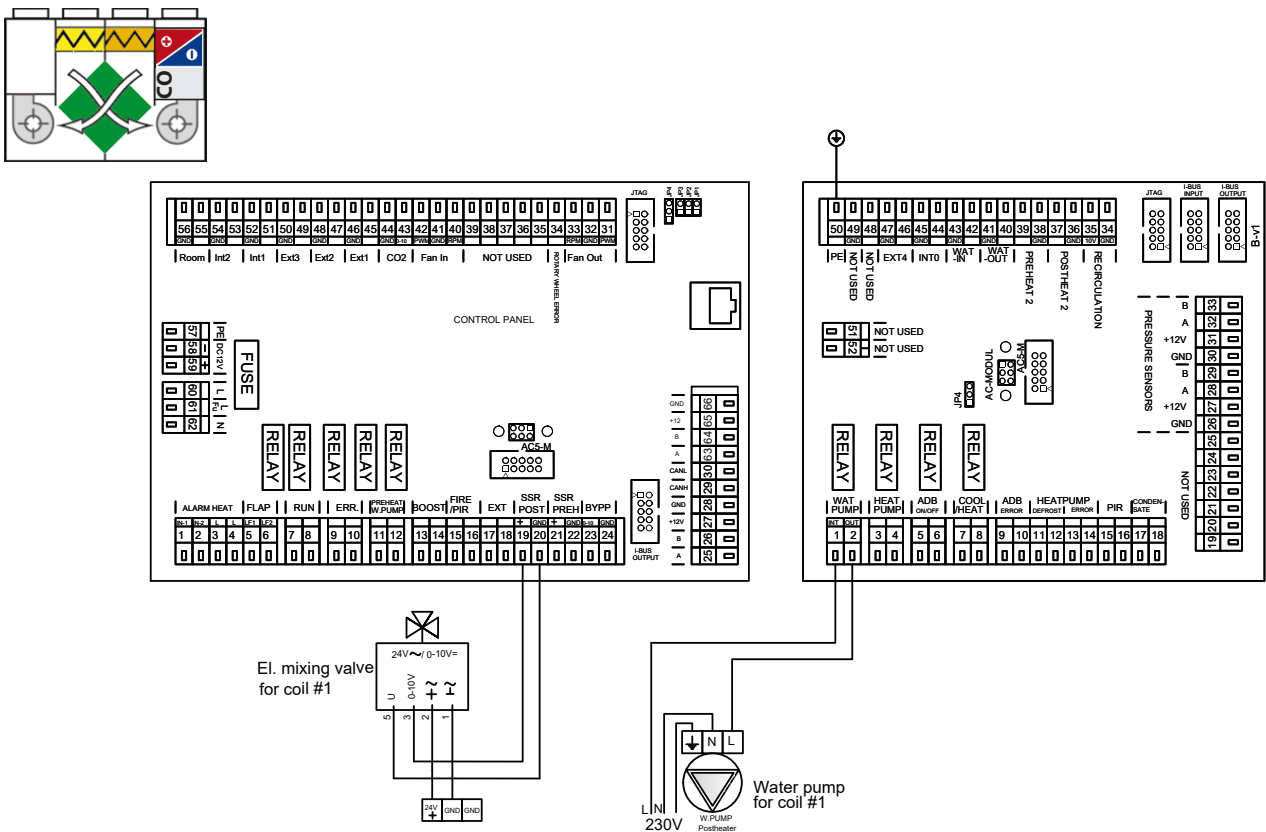

13. CONCLUSIONS



Read and observe the instructions herein for a safe and proper use of the unit. Do not hesitate to contact our sales or technical support department in case of any query or request for explanation.

The producer shall not be liable for damages caused as a result of improper installation and operation contrary to the manual and the common practice of installation and operation of ventilation devices and regulations systems.



Contact information:

2VV, s.r.o.
Nádražní 794
533 51 Pardubice - Rosice
Czech Republic

Internet:
<http://www.2vv.cz>

