



PARTNER
IN VENTILATION
2VV.CZ

EN

AirGENIO **BASIC EC** controller



Installation and operation instructions

CE

ABOUT THE MANUAL

Symbol	Meaning
	WARNING – these symbols warn about factors that may cause serious injury to the user or damage to the device. They also draw attention to important instructions, properties, procedures or measures that must be taken into account or abided by during operation and maintenance.
	ATTENTION – this symbol draws attention to an important activity or information that must be taken into account, but one that will not endanger health or damage the device.
	INFORMATION – this symbol draws attention to useful information about the device



This manual was written to provide necessary information about the AirGENIO BASIC EC controller concerning its operation, maintenance and service. Authorized persons must be thoroughly familiar with the contents of the manual before beginning any work with the device.



Declaration of conformity

The product has been designed, produced and marketed in compliance with all the applicable provisions, and abides to the provisions of the European Parliament and Council, including the amendments under which it has been classified. It is safe under normal conditions and under the conditions laid down by the manual. The assessment was conducted pursuant to harmonized European standards included in the relevant EC Declaration of Conformity. The current and full version of the EC Declaration of Conformity can be found at www.2wv.cz

IMPORTANT WARNINGS



- Read this manual carefully.
- Proceed exactly according to the instructions stated here in order to install controller properly and safely.
- Do not put the device into operation unless you are thoroughly acquainted with all the instructions, warnings and recommendations.
- Illustrations used in this manual may not always correspond to reality; their purpose is to help in understanding the installation steps. Texts, drawings, photos and other elements used here are, however, protected by copyright. Their abuse or unauthorised copying is a punishable offence.
- The manual must be considered an integral and inseparable part of the controller. Store it for future use and pass it on to any future owners.



- Avoid contacts with energised electrical parts; always treat the product as if it is live. Always disconnect the power supply before connecting, servicing or repairing the product
- Always verify that you apply appropriate power supply to the product and use appropriate wire size and characteristics. Make sure that all the screws are well tightened.

INFORMATION

Unexpected situations may occur in practice that could not be included and described in this manual. When in doubt about how to proceed, contact the manufacturer.

DELIVERY AND UNPACKING

PACKAGING AND CONTENTS OF THE DELIVERY

The controller is supplied as a single, complete whole, packaged to protect it against damage. The controller is transported in a cardboard box to protect the device from damage.

The delivery includes the following:

- Transport packaging
- Controller (1x)
- Instructions for Quick Installation and Safe Use of controller





Check immediately after unpacking:

- if the package is damaged
If it is damaged, contact the carrier company. If the complaint is submitted too late, it may not be accepted.
- if you received the controller type you ordered
If you find any defects or discrepancies, do not unpack the controller and immediately inform the supplier. If you do not submit your complaint on time, future complaints will not be accepted.

HANDLING THE DELIVERY



It is recommended that the device and load is only handled by persons with corresponding qualifications. Transport the delivery carefully to the place where it will be unpacked or stored.

STORAGE BEFORE UNPACKING

If you do not intend to unpack and install the controller immediately after delivery, store it in the following conditions:

- Store the controller in original packaging in a dry area protected against weather conditions that could damage the packaging and negatively affect the condition of the device. The ambient temperature must be between **+5 °C** and **+40 °C**.
- Do not remove the controller from the box.

DEVICE DESCRIPTION

INTRODUCTION

AirGENIO BASIC EC controller is designed to control the air curtains and heating units with electric or water coils, using manual heating control and manual stepless fan speed control. Controller allows to connect up to two external switches (one to affecting the heat and one to affecting the fan speed)

Ambient version of controller doesn't allows to control heating and doesn't support connection of room thermostat.

CONTROLLER IDENTIFICATION

AGBA1 - M - ECx-xx - E2

①

②

③

④

BASIC EC ambient
AGBA1-M-ECx-xx-S0



BASIC EC heater
AGBA1-M-ECx-xx-E2 (V1)



- 1 – Code for AirGENIO BASIC EC controller
- 2 – Master controller
- 3 – for EC fans only
- 4 – Heater type:
E2 = BASIC EC with electric
V1 = BASIC EC with water heater control
S0 = BASIC EC without heater control

DIMENSIONS

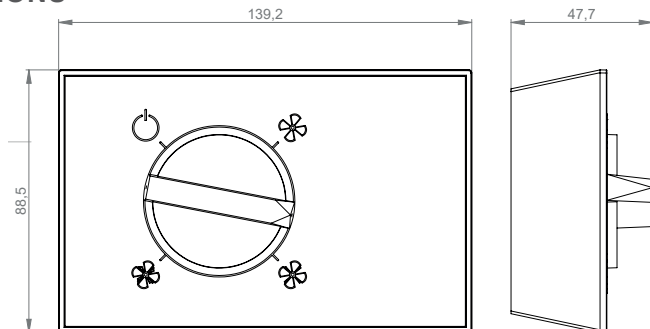

INSTALLATION

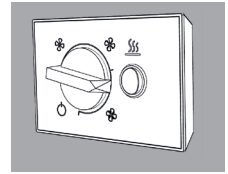
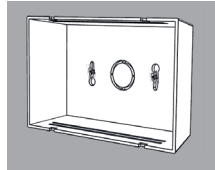
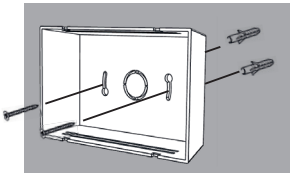
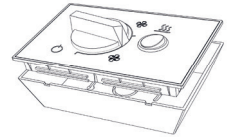
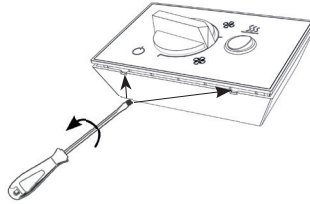

The controller can only be installed on a wall or on a solid non-portable object.
The cable must be secured against being pulled out from controller.

OPERATION

1	OFF - Fan OFF, heating disabled
2	Low fan speed, heating enabled (Heat level 1 enable)
3	Middle fan speed, heating enabled (Heat level 1 and 2 enable)
4	High fan speed, heating enabled (Heat level 1 and 2 enable)
5	Heat switch (Water heater = Heat level 1, Electric heater = Heat level 1 and 2)

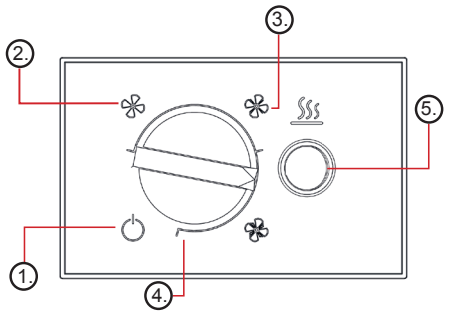

CONTROL DESCRIPTION

Controller allows:

- Control EC motors by stepless 0-10V output
- Control the power of the heating in range OFF/1st stage/2nd stage, by potential free relay outputs with maximum load of relay 230V/5A. NOTE: Not available for ambient version of controller
- Connect door contact or external switch (turning OFF whole product after contact opening)
- Connect the room thermostat (turn OFF the heater after contact opening) - **NOTE: Not available for ambient version of controller**

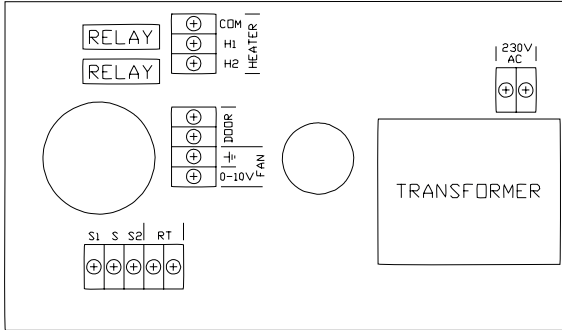

TERMINAL	FUNCTIONALITY	DESCRIPTION
S1	INPUT FOR INTERNAL HEAT SWITCH OF CONTROLLER	SWITCH FOR 1ST HEAT STAGE (FACTORY CONNECTED)
S		COM OF INTERNAL HEAT SWITCH (FACTORY CONNECTED)
S2		SWITCH FOR 2ND HEAT STAGE (FACTORY CONNECTED)
RT	ROOM THERMOSTAT	DI SWITCHING ON/OFF HEAT OUTPUTS ONLY (FACTORY CONNECTION = EL. BRIDGE)
COM	COM HEATING	INPUT FOR HEAT. CONTROL SIGNAL (MAX. LOAD 230V/5A)
H1	1ST HEATING STAGE	OUTPUT OF 1ST HEATING STAGE
H2	2ND HEATING STAGE	OUTPUT OF 2ND HEATING STAGE
DOOR	DOOR CONTACT (EXT CTRL., ROOM THERMOSTAT)	DI SWITCHING ON/OFF WHOLE CONTROLLER (FAN AND HEATING)
0-10V DC	0-10V FAN SPEED	OUTPUT FOR FAN SPEED CONTROL (MAX. 10PCS)
GND	GND FAN SPEED	
~230V	L - 230VAC	POWER SUPPLY 230V
	N - 230VAC	

NOTE: Terminals S1, S, S2, RT, COM, H1, H2 not used for ambient version of controller. Ambient version supports only fan control and connection of external contact on terminals DOOR. (Door switch, external control switch,...)

INPUTS AND OUTPUTS

Inputs:

RT - Room thermostat

NOTE: Not used for ambient version of controller

- Input is set to connect an external, potential-free contact of room thermostat to switching on / off heating outputs H1 and H2 according state of room thermostat
- Controller responds to the connected/disconnected contact on the input (switching on / off heating), fan continues to run normally
- Default connection: connected contact (electrical bridge)
- Connected contact = Heating outputs H1 or H1 and H2 is ON if heating is set to be used
- Disconnected contact = Heating outputs H1, H2 is OFF, even if heating is set to be used

DOOR – Door contact (room thermostat, external switch)

- Input is set to connect an external, potential-free door contact or room thermostat or external switch, to switch ON/OFF fan output and heating outputs.
- Controller responds to the connected/disconnected contact on the DOOR input, switching on / off whole controlled product. After OFF command is received the 5 seconds overrunning time is applied and then controlled product is set to OFF mode.
- Default connection: disconnected contact (without electrical bridge)
- Connected contact = product is switched to OFF (overrunning time is applied)
- Disconnected contact = controlled product runs on preset fan speed value and heating output

Outputs:

HEAT 1 – H1 (potential free output on board connected with terminal COM - Relay)

NOTE: Not used for ambient version of controller

- Controlled heating equipment of the controlled product is connected to terminal H1 - e.g.: 1st stage of heating by contactor
- Terminal COM is designated as input for control signal of the heating. Maximum load of relay contact is 230V/5A (Control signal for heat can be used according installation needs e.g. 24VAC, 24VDC, 230VAC, depend on ON/OFF actuator selection)
- Connection output H1 is handled as 1st heating stage (contactor control signal or three-way valve opening phase)
- H1 output is switching power led to terminal COM

Functionality:

- HEAT 1 (H1) output is active only when control voltage to the ec fan speed output overcross value 1,7V at last. (WARNING: Be sure that controlled EC fan in the product is able to start before 1,7V control signal, to avoid start heating earlier then fan starts!!!)
- HEAT 1 (H1) output is active when starting 1st stage of heating as well as at start of 2nd heating stage HEAT 2 (H2) = HEAT outputs are switched in cascade
- HEAT 1 (H1) output is inactive in case room thermostat contact connected to ROOM THERMOSTAT (RT) input is disconnected.

HEAT2 – H2 (potential free output on board connected with terminal COM - Relay)

NOTE: Not used for ambient version of controller

- Controlled heating equipment of the controlled product is connected to terminal H2 - e.g.: 2nd stage of heating by contactor
- Terminal COM is designated as input for control signal of the heating. Maximum load of relay contact is 230V/5A (Control signal for heat can be used according installation needs e.g. 24VAC, 24VDC, 230VAC, depend on ON/OFF actuator selection)
- Connection output H2 is handled as 2nd heating stage (contactor control signal or three-way valve opening phase)
- H2 output is switching power led to terminal COM

Functionality:

- HEAT 2 (H2) output is active only when control voltage to the EC fan speed control output overcross 5V.
- HEAT 2 (H2) output is active when 2nd heating stage is selected and fan control signal value overcross the limit for 2nd heating stage enable. Then HEAT 2 (H2) output is activated. HEAT outputs are switched in cascade, it means that H1 output is active when H2 is active.
- HEAT 2 (H2) output is inactive in case room thermostat contact connected to ROOM THERMOSTAT (RT) input is disconnected.

0-10V/GND FAN speed output: Terminals: 0-10V, GND (Analog EC Fan Control Output)

- Output designed for stepless of EC fans control in range 0-10V signal. Maximum starting voltage signal for EC fan must be lower or equal to 1,7V, because 1,7V is the value when Heat 1 output is activated.
- Heat 2 output is activated when fan speed control signal overcross 5V.
- The maximum number of EC fans connected to this output is 10.



WARNING: Be sure that controlled EC fan in the product is able to start before 1,7V control signal, to avoid start heating earlier then fan starts!!!



WARNING: Length and execution of fan speed control signal cabling has influence of voltage drop of the signal 0-10V! Measure voltage of the control signal, on fan speed control input on the controlled fan to be sure that fan starts before heating outputs are activated.

BASIC EC (AGBA1-M-ECx-xx-V1) with two EC fans - Electric heater with one step:

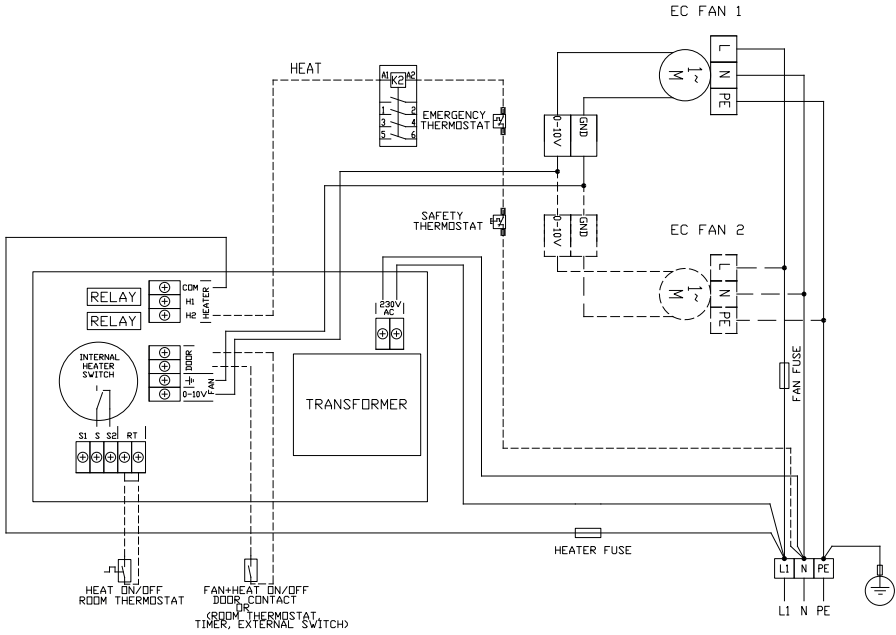

BASIC EC (AGBA1-M-ECx-xx-S0) with two EC fans:

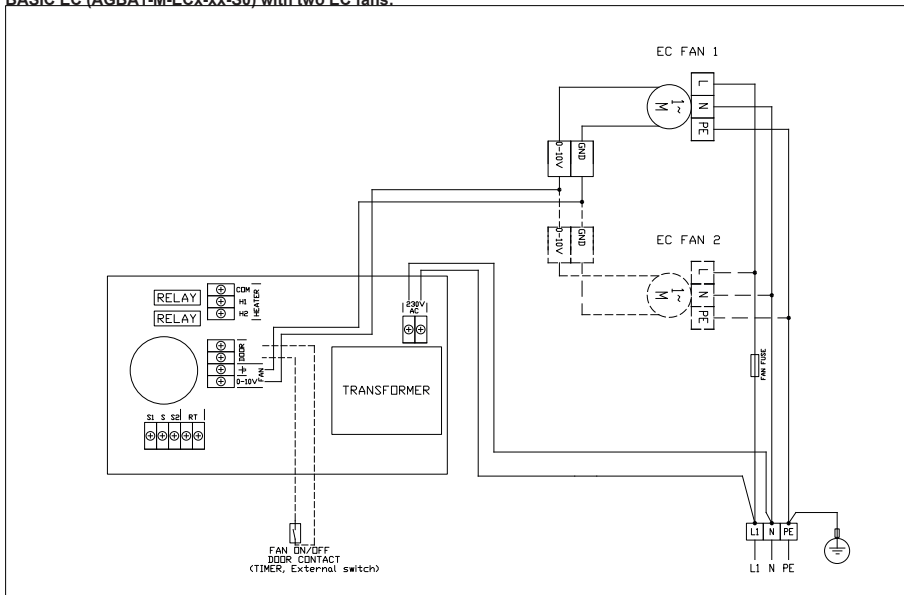

RULES FOR SAFE OPERATION

- Control and operate the controller only in accordance with this manual.
- Always abide by the controllers operating temperatures.
- Do not overstress the structure of the controller.
- The controller should be protected by a suitable circuit breaker



In the event of fire, the controller must be extinguished with a CO₂ or powder fire extinguisher. Never extinguish it with water!

STORAGE AND DISPOSAL

STORAGE

Store the controller as follows:

- 1 Wrap the controller in suitable material, such as plastic film, canvas etc. or place it in a suitable box.
- 2 Transport the controller into a dry space that is protected from weather conditions that could damage the packaging and negatively affect the controller. The ambient temperature must be between +5 °C and +40 °C.
- 3 Do not place any heavy objects or material on top of the stored controller.

DISPOSAL ONCE THE CONTROLLER IS OUT OF OPERATION



When disposing of the controller, follow relevant regulations on waste disposal. It is best to dispose of components at a specialised collection point to ensure recyclable materials are reused. Take any non-reusable parts of the air curtain to a controlled waste dump.

2VV s.r.o.
Nádražní 794
533 51 Pardubice - Rosice
Czech Republic

+420 466 741 811
2vv@2vv.cz
www.2vv.cz

