



PARTNER
IN VENTILATION
2VV.CZ

EN

DAPHNE

INSTALLATION



4-118-0320

EAC

CE

01 BEFORE STARTING

The following symbols in the manual serve for better guidance. The following table describes the symbols and their meaning.

Symbol	Meaning
ATTENTION!	Warning or Caution
PLEASE NOTE!	Important instructions
YOU WILL NEED	Practical tips and information
TECHNICAL INFORMATION	Detailed technical information
	Reference to a different part of the manual



Before installing the unit, **read carefully the section on the safe operation of the heat recovery unit**. You will find instructions on the safe and proper use of the product.

This manual provides instructions on how to properly install the unit. Before installing the unit, read carefully the entire manual. The manufacturer reserves the right to make changes, including in the technical documentation, without prior notice. Keep the manual in a safe place for future reference. The manual is an integral part of the product.

Declaration of conformity

The product has been designed, produced and marketed in compliance with all the applicable provisions, and abides to the provisions of the European Parliament and Council, including the amendments under which it has been classified. It is safe under normal conditions and under the conditions laid down by the manual. The assessment was conducted pursuant to harmonized European standards included in the relevant EC Declaration of Conformity. The current and full version of the EC Declaration of Conformity can be found at www.2vv.cz

02 UNPACKING

PLEASE CHECK THE DELIVERED PRODUCT



PLEASE NOTE!

- Unpack the product upon delivery and control for damages. In case of damage, inform and file a report with the carrier.
- Any claims that have not been filed in due time, will be disregarded later.
- Check that you have received the model ordered. Should the delivered model differ from the one ordered, do not unpack the unit and notify the supplier immediately.
- After unpacking, check that the unit and the accessories are in good order. Contact the supplier in case of any doubt.
- Do not attempt to commission a damaged ventilation unit.
- If the unit is not unpacked upon delivery, it must be stored in a dry room a temperature range of **+5 °C to +40 °C**.
- This product must not be used by persons (incl. minors) with mental or physical disabilities, or insufficient experience or knowledge in the safe use thereof, unless they are supervised or instructed on how to use the product by a person responsible for their safety.
- Do not let children play with the unit.

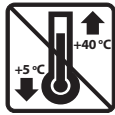

	<p>All the packing material is environmentally friendly and can be reused or recycled. Please, contribute actively to the protection of the environment and procure the regular disposal or recycling of packing materials.</p>	
--	---	--

UNPACKING THE UNIT

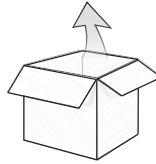

DAPHNE Comfort

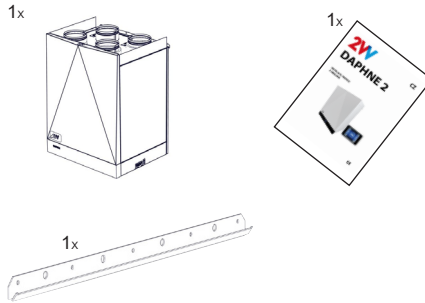

ATTENTION

- Detach design cover when unwrapping the unit
- Do not hold the unit by the plastic cover of the regulator when unwrapping.



PLEASE NOTE!

- If the unit was shipped at below 0°C temperatures, let it rest for at least 2 hours, without turning it on, so that its inner temperature can match the surroundings.

03 MAIN PARTS

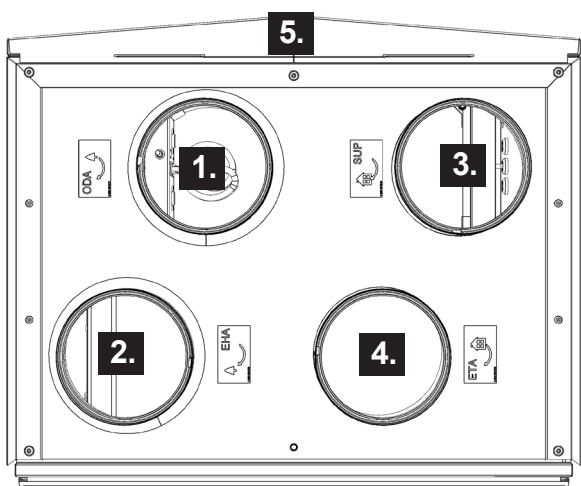

- 1. Duct connection - outdoor air (ODA)
- 2. Duct connection - exhaust air (EHA)
- 3. Duct connection - supply air (SUP)
- 4. Duct connection - diverted air (ETA)
- 5. Front design cover
- 6. Removable cover for filter replacement
- 7. Fan.
- 8. Exchanger
- 9. Condensate drain
- 10. Filter G4 (intake), Filter G4 (exhaust) + prefilter G2 (selection).
- 11. Control panel
- 12. Regulation unit - Connecting power and accessories

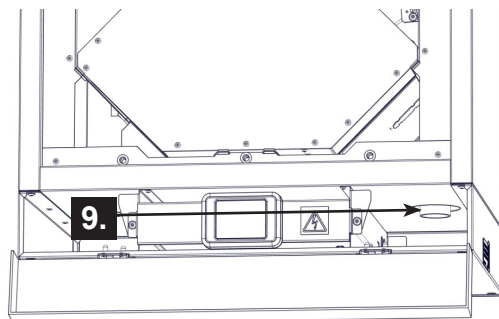
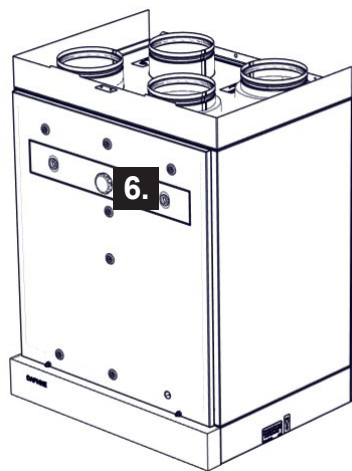
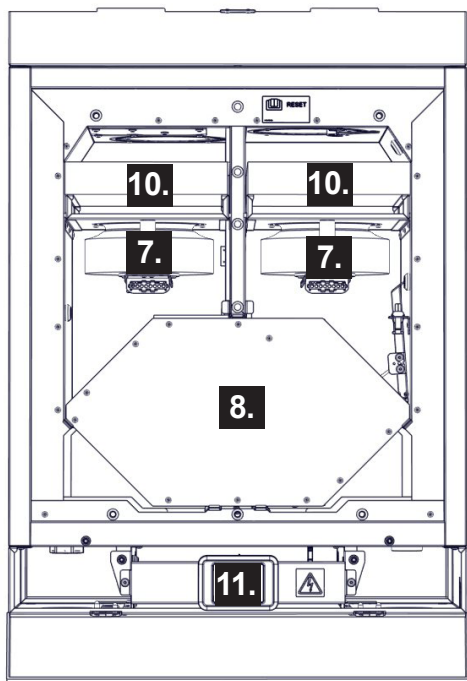

12.

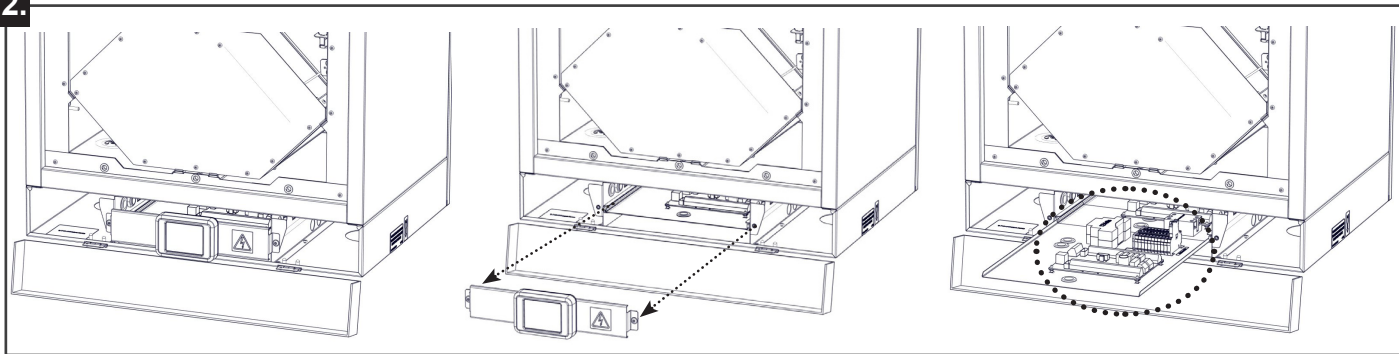

04 DIMENSIONS

HRDA2-020 + HRDA2-030

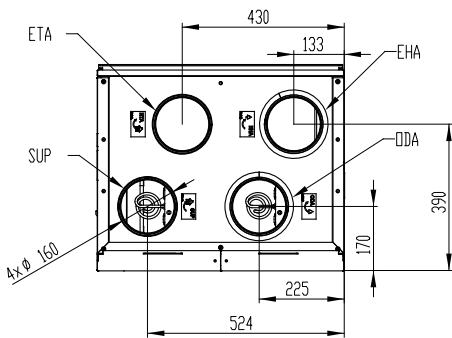
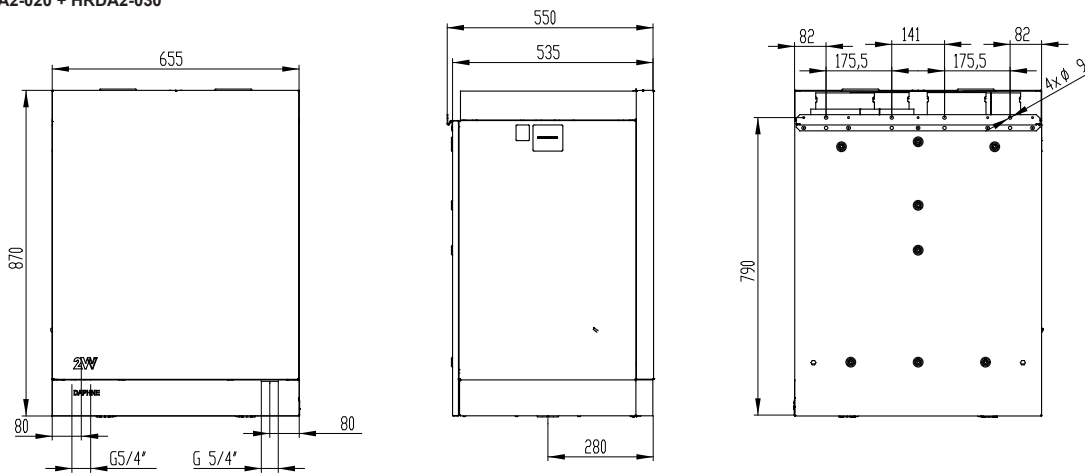

HRDA2-050

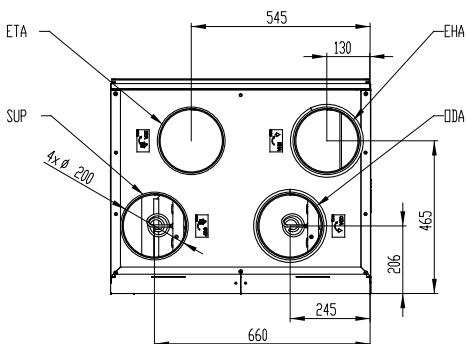
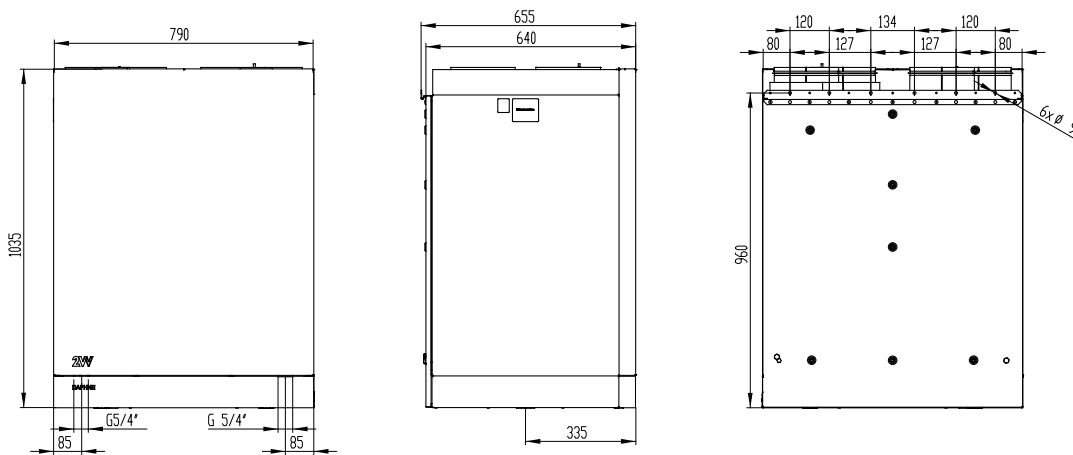

04 DIMENSIONS

HRDA2-070/090

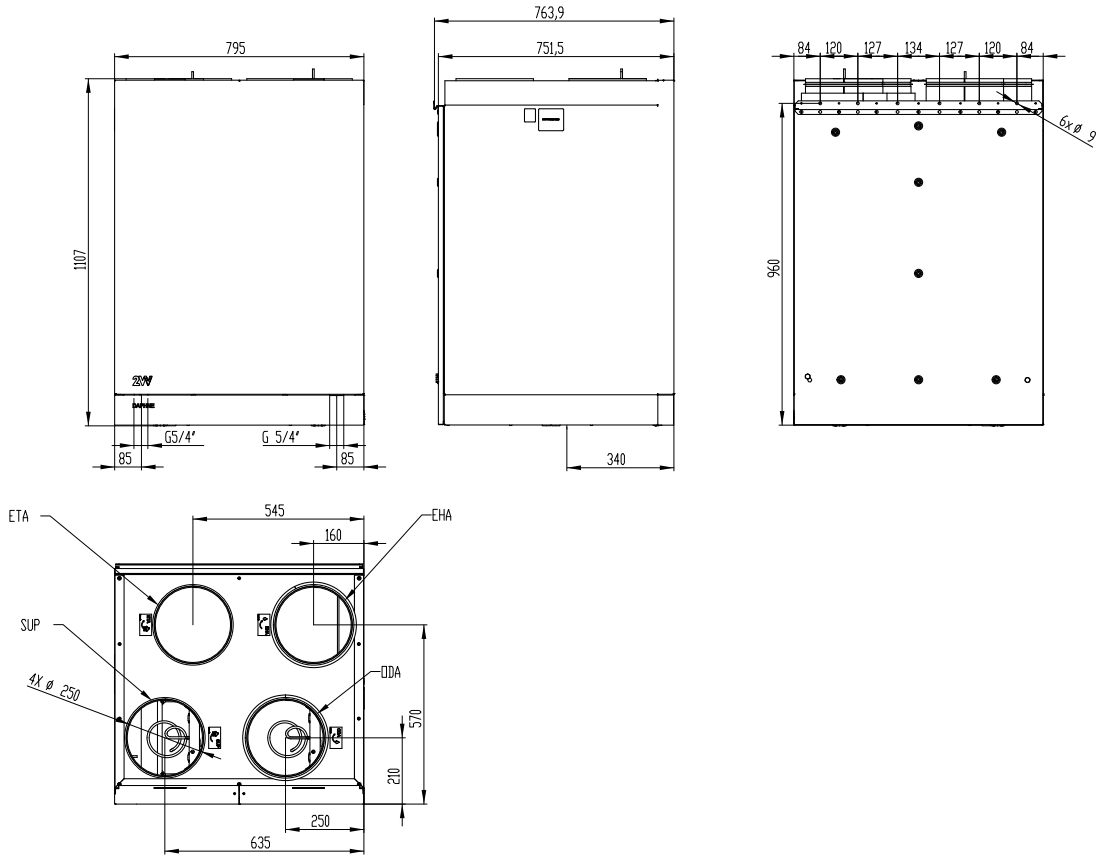

05 TECHNICAL PARAMETERS

Model	Nominal air flow [m³/h]	Qty. phase [pcs]	Tension [V]	Frequency [Hz]	Max. fan power [W]	Power consumption preheating [kW]	Power consumption reheating [kW]	Weight [kg]
HRDA2-020... ES0C	200	1	230	50	120	0,6	-	50
HRDA2-020... EE1C	200	1	230	50	120	0,6	0,8	51
HRDA2-020... XE1C	200	1	230	50	120	-	0,8	50
HRDA2-020... XS0C	200	1	230	50	120	-	-	49
HRDA2-030... ES0C	300	1	230	50	170	0,6	-	50
HRDA2-030... EE1C	300	1	230	50	170	0,6	0,8	51
HRDA2-030... XE1C	300	1	230	50	170	-	0,8	50
HRDA2-030... XS0C	300	1	230	50	170	-	-	49
HRDA2-050... ES0C	500	1	230	50	240	1,2	-	70
HRDA2-050... EE1C	500	1	230	50	240	1,2	0,8	71
HRDA2-050... XE1C	500	1	230	50	240	-	0,8	70
HRDA2-050... XS0C	500	1	230	50	240	-	-	69
HRDA2-070... ES0C	700	1	230	50	400	1,8	-	88
HRDA2-070... EE1C	700	3	400	50	400	1,8	1,2	89
HRDA2-070... XE1C	700	1	230	50	400	-	1,2	88
HRDA2-070... XS0C	700	1	230	50	400	-	-	87
HRDA2-090... ES0C	900	1	230	50	800	1,8	-	88
HRDA2-090... EE1C	900	3	400	50	800	1,8	1,2	89
HRDA2-090... XE1C	900	1	230	50	800	-	1,2	88
HRDA2-090... XS0C	900	1	230	50	800	-	-	87



Other technical data can be found in the technical catalog - www.2vv.cz

06 INSTALLATION

CHOOSING THE PLACE



The project of the ventilation system must be prepared by a HVAC designer.



TECHNICAL INFORMATION

The unit must be operated in a closed, dry place with a range of temperatures of **+5°C to +40°C**. Fresh intake air should have a temperature ranging from -20°C to +40°C and relative humidity of up to 90%.

CONDITIONS OF USE OF THE ENTHALPY EXCHANGER: if the outside temperature does not drop below -5°C, the indoor relative humidity is less than 45%, the indoor temperature is up to 23°C so there is no need for condensate drainage. In case of other conditions such as lower outdoor temperature or higher indoor temperature or higher indoor humidity, a condensate drain must be installed.



Condensation within the unit:

If the unit is placed in an attic space (temperatures may approximate outdoor temperatures), it is necessary for the unit to run continuously. If the unit can be turned off manually by the user or an automatic timer, it is necessary to install airtight shutters with emergency functioning on the intake and exhaust ducts. The shutters will ensure that no air from the warm parts of the building will flow through the unit (stack effect). If no shutters have been installed, there will be a risk of condensation within the unit and exterior ducts at the time the unit is deactivated. This may also result in cold exterior air flowing into the building. In that case condensation can also occur within the intake and exhaust ducts or even in valves placed in rooms. If the unit is not running for a long period of time during winter, the intake and exhaust ducts should be closed so that the above effect does not occur after this period. Condensation outside the unit If the unit is placed in a moist area (e.g. a laundry room), condensation in the external parts of the sheath may occur when combined with low exterior temperatures. If condensation occurs outside the unit, increase the ventilation in the surroundings of the unit.

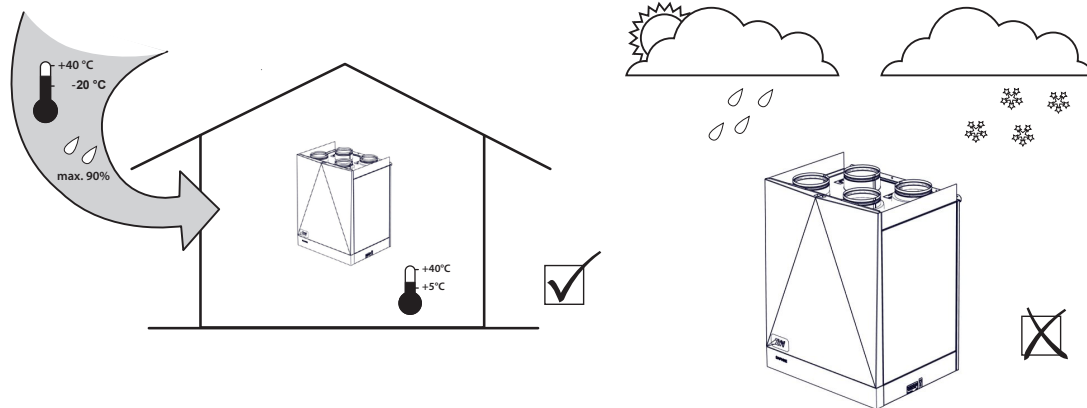

06 INSTALLATION

The unit is not designed to filter air containing combustible or flammable particles, chemical fumes, coarse dust, carbon, grease, poisons, bacteria, etc.

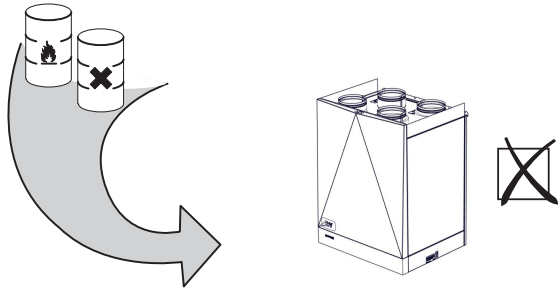

The IP protection level of the unit in the ducts is IP 20 (protection against objects bigger than 12.5 mm, does not protect against water).

Installation distance

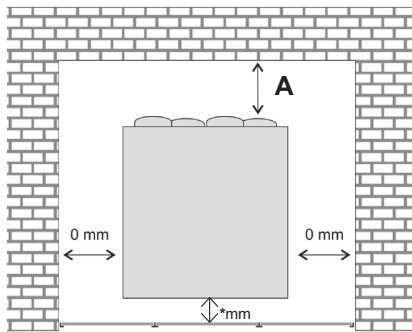

These dimensions are suitable for service access.

* it is necessary to leave enough space to connect a sink.

A	HRDA2-020	min. 250mm
	HRDA2-030	min. 350mm
	HRDA2-050	min. 500mm
	HRDA2-070	min. 700 mm
	HRDA2-090	min. 700 mm

TECHNICAL INFORMATION

• All the models of the heat recovery unit can be installed in the following positions:

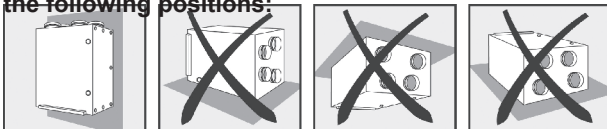

- Any other position is forbidden.
- The unit must be installed so that the direction of the air circulation will correspond with the air circulation in the distribution system.
- The installation must allow access for maintenance, service or disassembling. Access relates mainly to opening the revision lid.

Required distance

ATTENTION

The intake and exhaust vents must not be blocked by non-combustible material.

- The safe distance between combustible materials and the intake is 250 mm.

Installing the unit

- Service doors can be mounted in the place of the rear panel of the unit and thereby reverse the HVAC connection and condensate exhaust.

Installation on wall

Dimensions of the wall bracket: (included)

HRDA2-020 / HRDA2-030

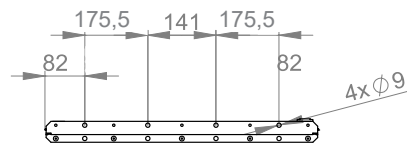

HRDA2-050 / HRDA2-070 / HRDA2-090

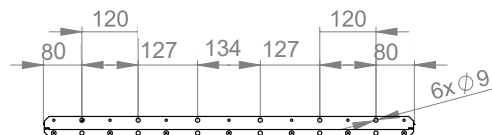

- Measure the location appropriately.
- Drill holes in the wall and fix the bracket included.

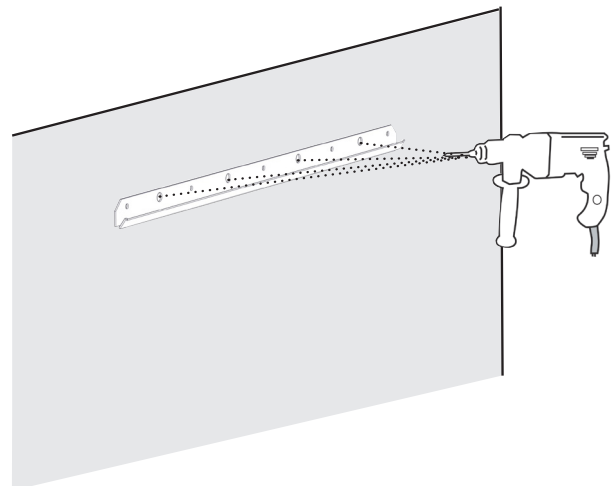

Fix the bracket appropriately with 4 M8x80 screws and washers. (non included)

06 INSTALLATION

- Hang the unit on the bracket

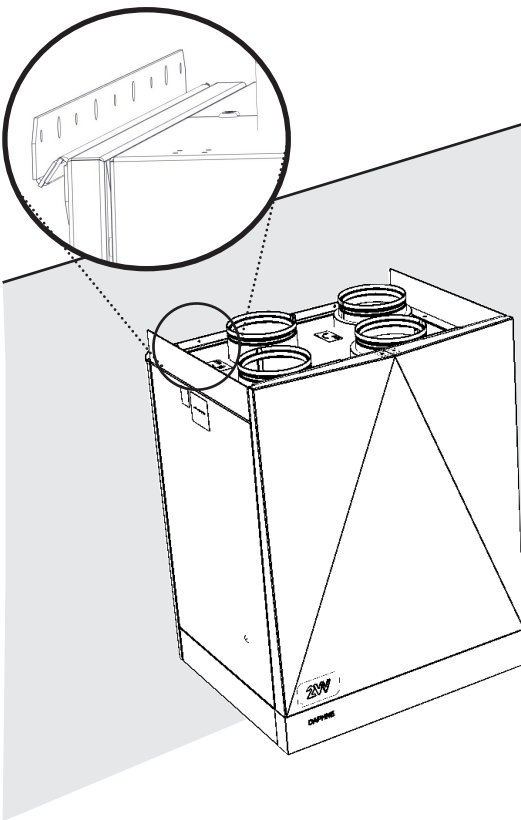
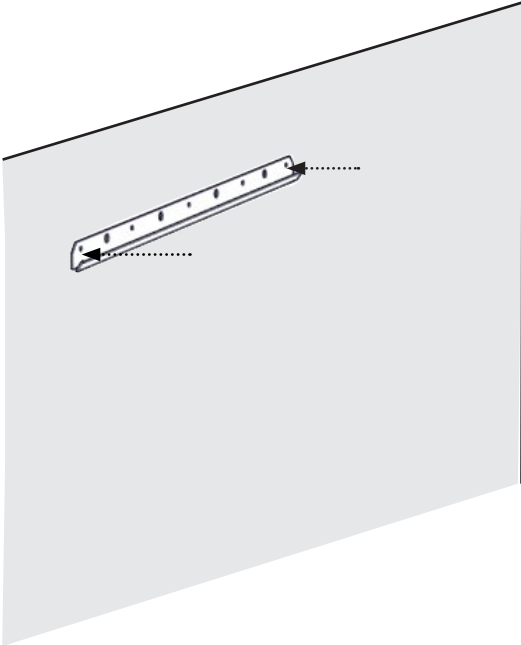

- Level de unit horizontally with the adjustment screws on the back.

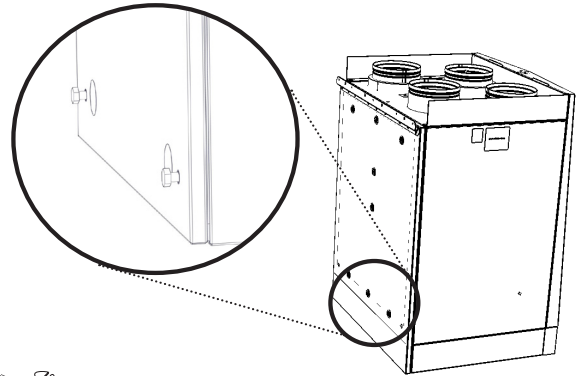

YOU WILL NEED

- Water level
- No. 13 wrench

06 INSTALLATION

Installation on base.

Check the contents of the package.

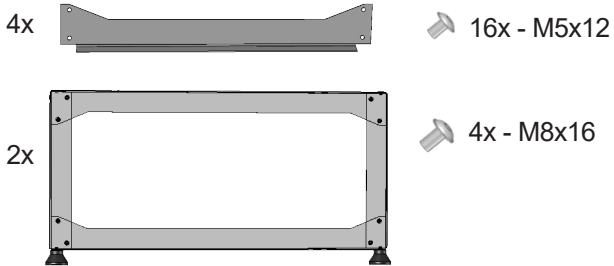

Connect the parts when using screws 5,0x12 (torx).

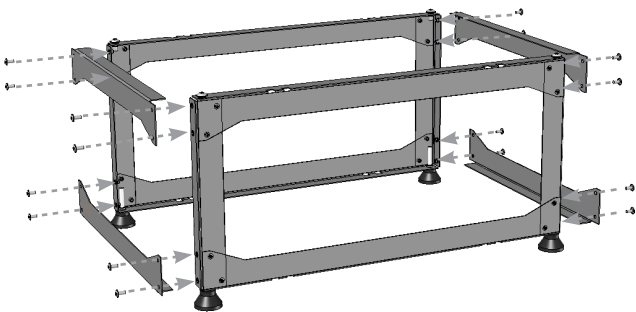

Straighten the base with adjustable legs to the plane. To attach the device to the base, it is necessary to remove the back cover from the device, therefore we recommend leaving a distance of at least 80 cm from the wall during installation.

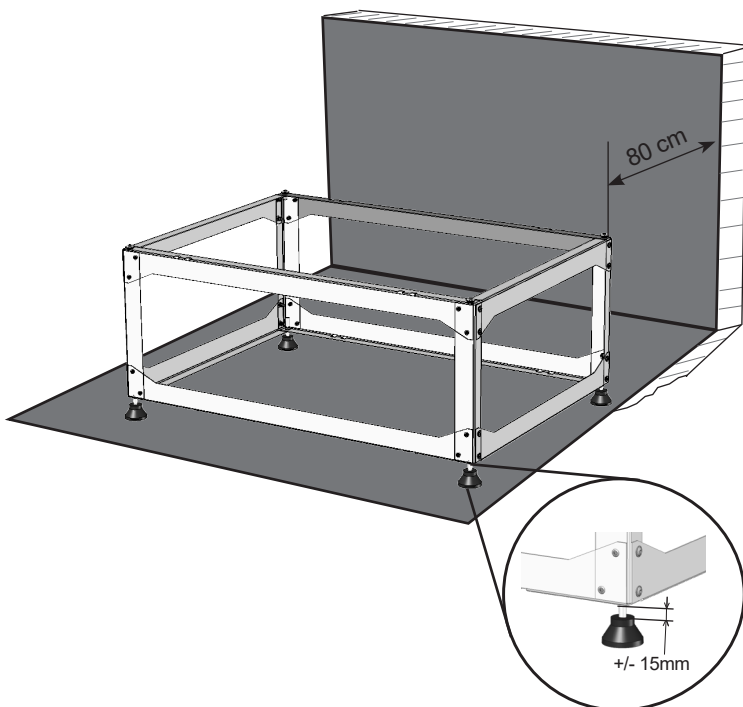

Place the device on the stand and remove the back cover from the device.

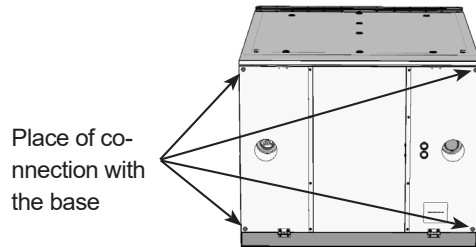
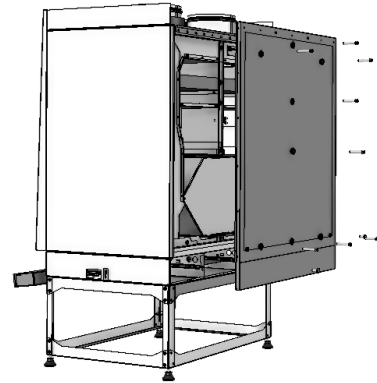

Screw the unit to the pedestal with 4 screws M8x16.

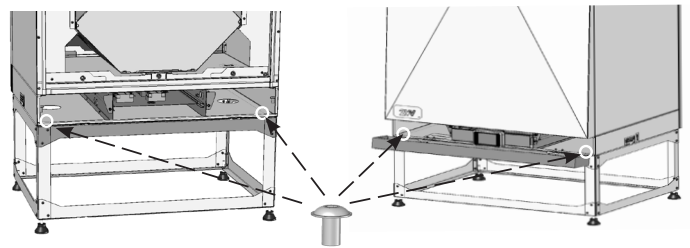

Install the back cover on the unit. Check the locking.

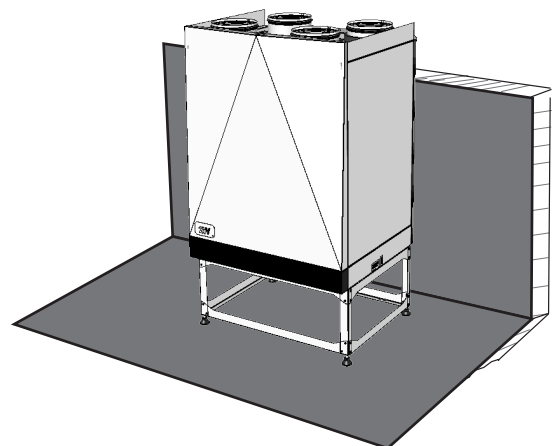

06 INSTALLATION

HRDA2-BASE-200-300

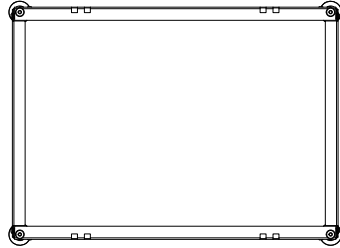
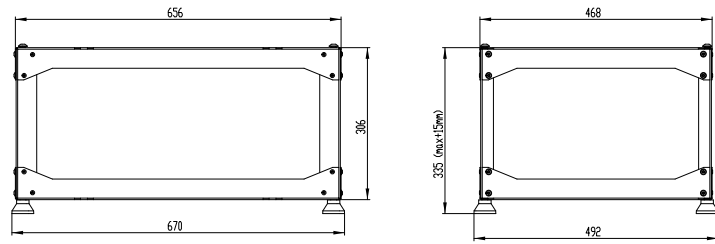

HRDA2-BASE-500

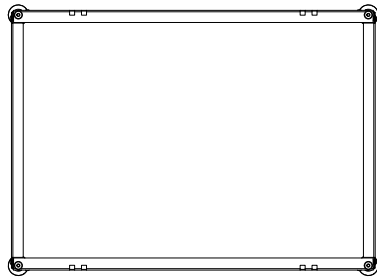
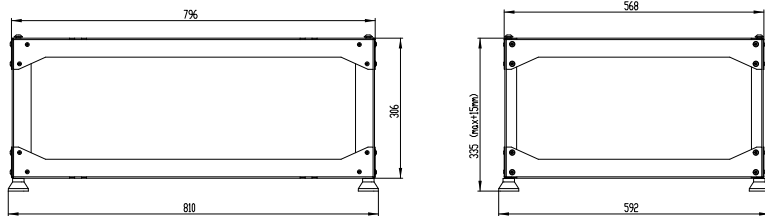

HRDA2-BASE-700-900

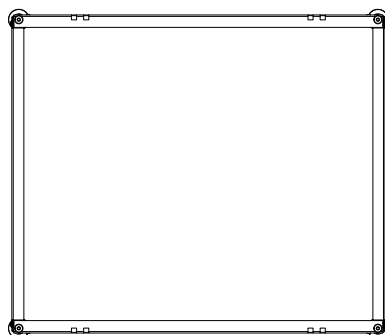
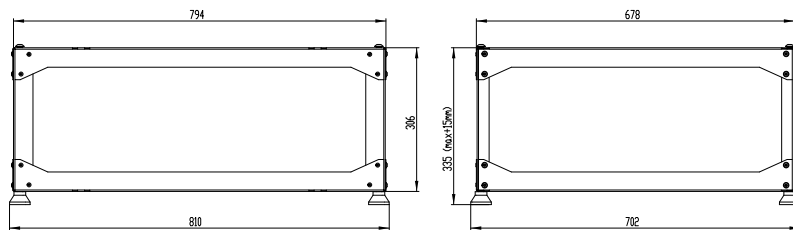

06 INSTALLATION

CONNECTING THE CONDENSATE DRAIN



PLEASE NOTE!

- The sink must have a quality connection and seal to the recuperation unit.
- We recommend to submerge each sink in water to check its integrity.



ATTENTION!

If the sink is not well connected, the unit may be flooded and damaged.

The sink (SK-AKS3) can be installed directly on the unit. (not included)

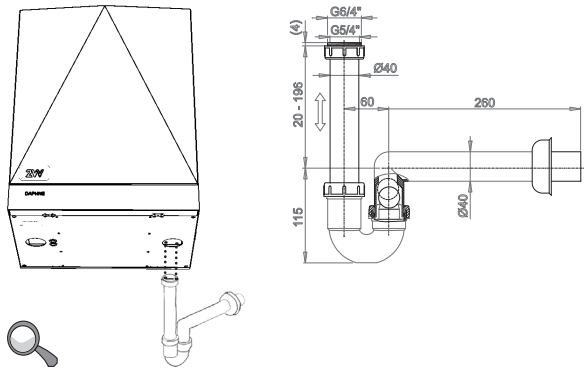

Units with reversed service access will have the sink on the left side (the original unit delivered will have the sink on the right side, per the figure above).

Daphne unit is equipped with the ability to connect a second condensate drain in places where summer conditions require it. This second condensate drain must be connected when the dew point temperature of the inside air is lower than the outdoor air coming into the building. These situations may occur, especially in hot summer, when the high temperature and humidity of the outside air crosses the low temperature exhaust air inside the heat recovery core (e.g., + 25 ° c and + 35 ° c between the inside air and the outside air, with a relative humidity above 60%). Therefore, we recommend that you install a second (during summer) condensate drain especially for chilled air conditioning buildings located in tropical climates.

CONNECTING HVAC DUCTS

Connect the ductwork to the outlet and seal the joint with a aluminium tape or a coupling. This will prevent the transmission of vibrations. Sonovac – pull the outer aluminum casing over the sealed outlet to prevent any condensation on the ducts.

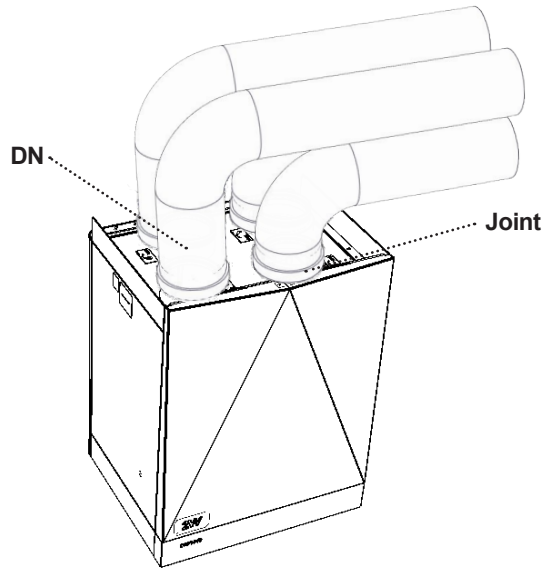
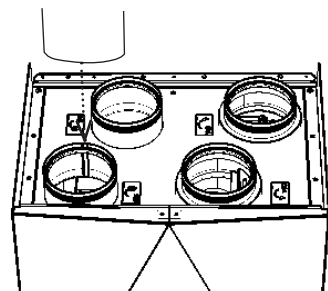

Model	DN
HRDA2-020	160
HRDA2-030	160
HRDA2-050	200
HRDA2-070	250
HRDA2-090	250

INSTALLATION OF A FILTER BOX IN THE DUCT

If unit is equipped with preheating, then it is recommended to install in the outside air duct (ODA) a filter box of type FLF-A or FLK-B. This will prevent air pollution and the ingress of dirt on the electric heating element.

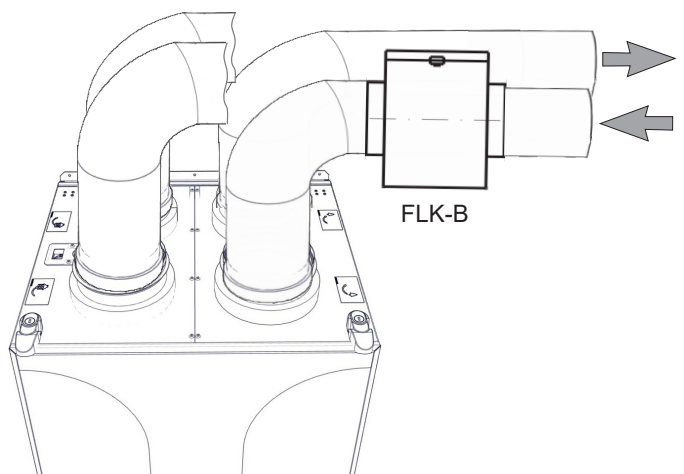

06 INSTALLATION



YOU WILL NEED

- Sealing tape



PLEASE NOTE!

- The connected ducts must have the same diameter as the socket of the unit. Smaller ducts may reduce the performance of the unit and, as result, the lifespan of the fans.
- All connections between ducts distributing air and the unit must be sealed with sealant material or sealing tape.

ELECTRIC INSTALLATION AND WIRING



ATTENTION!

- The main power supply must be turned off before working on the internal parts of the unit.
- The electrical installation must be done pursuant to the technical documentation and by a certified electrician. The installation might be done by a professional with qualifications in electricity. The manual must be observed, together with the laws and regulations applicable in the country.
- The wiring diagrams in the product have a higher priority than those in manual. Before the installation, check that the indication of the terminals corresponds to the wiring connection diagram. In case of doubt, contact the supplier and do not connect the unit under any circumstances.
- The unit must be connected to the main power source with an isolated cable with a heat resistance in compliance with the diameter and the applicable laws and regulations of the country.
- Any altering or changes to the internal connections of the unit are forbidden and may result in the loss of warranty.
- Only the use of original accessories guarantees the correct function of the unit.

Model	
U = power	I = total current
F = frequency	P = power
N = speed of ventilation	M = weight
Ph = number of phases	IP = el. protection
Av = air flow	Ver = version
Serial number	

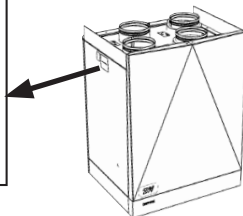

TECHNICAL INFORMATION

- The electrical parameters can be found on the manufacturer's labels inside and on the side of the unit.

All the unit's electrical circuits must be connected through an earth leakage breaker according to the current model. The unit must be connected in a way that it can be disconnected from the power supply with one piece.

Electronic accessories

Connect the electric accessories of the unit to the connecting terminal, as shown in the diagram and the indications of the terminals.

AirGENIO comfort regulation: Automatically controlled unit with external sensors

- **CO₂ room sensor**
CI-CO₂-R - CO₂ sensor used in automatic mode for activating/deactivating the unit according to the level of CO₂ in the air. Limit values must be set for the sensor.
- **Relative humidity room sensor**
CI-RH-R - RH sensor used in automatic mode for activating/deactivating the unit according to the level of relative humidity in the air. Limit values must be set for the sensor.

PLEASE NOTE!

- The accessories must be powered with their with their own external supply.
- For details on the power supply, refer to the documentation of the given accessory.

06 INSTALLATION

Changing door position

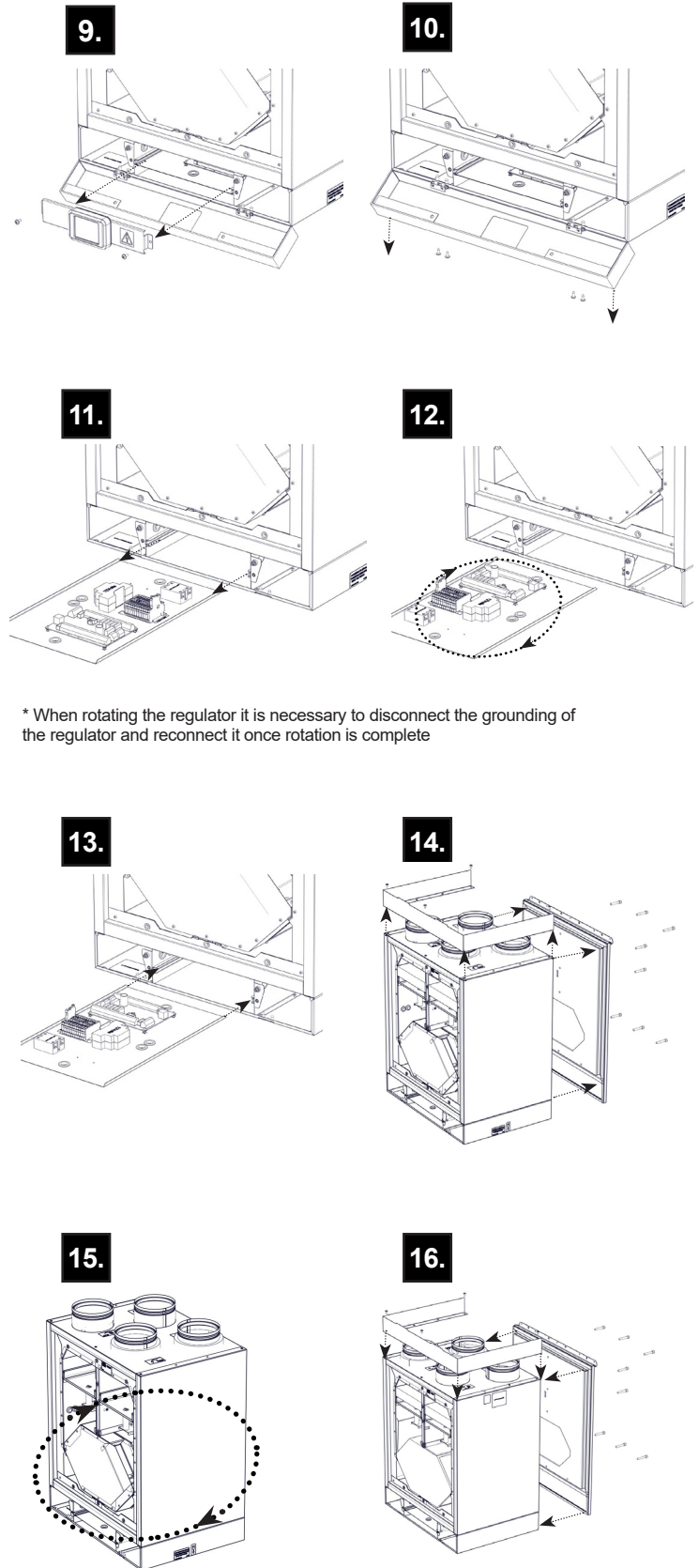
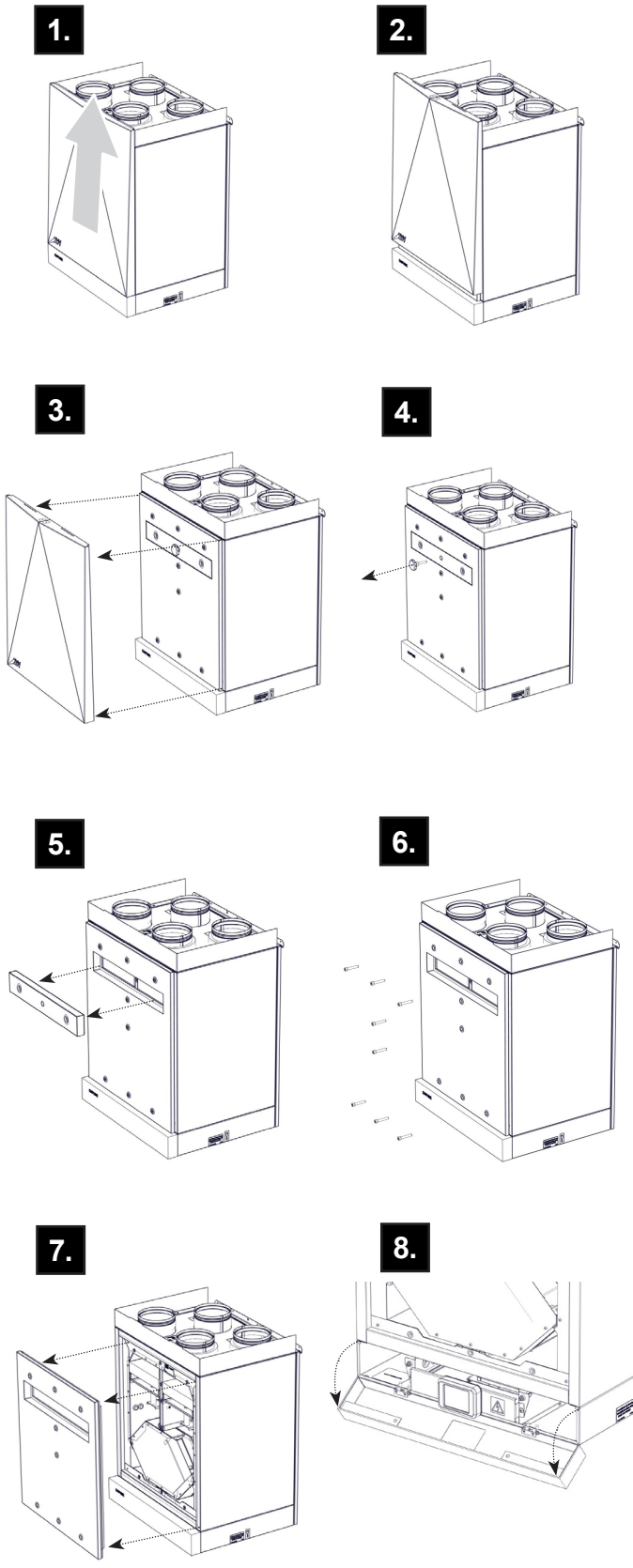

* When rotating the regulator it is necessary to disconnect the grounding of the regulator and reconnect it once rotation is complete

06 INSTALLATION

16.

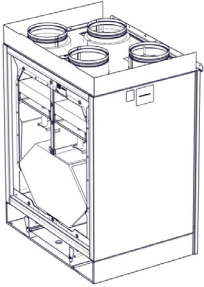

17.

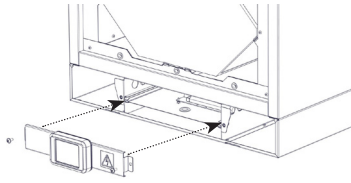

18.

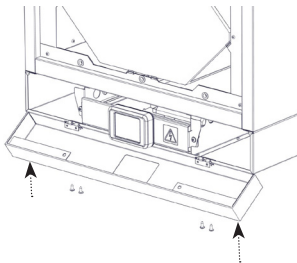

19.

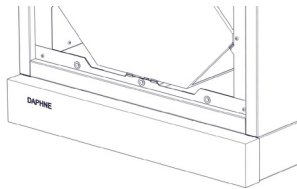

20.

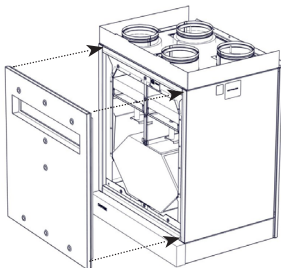

21.

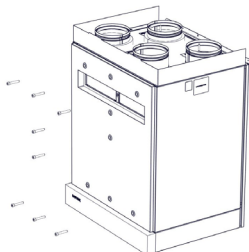

22.

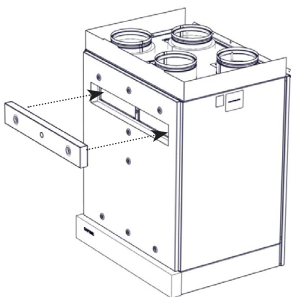

23.

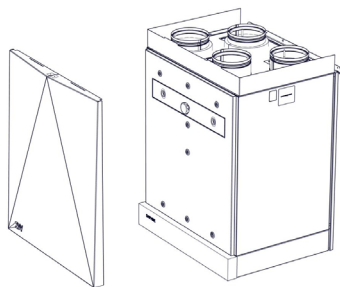

24.

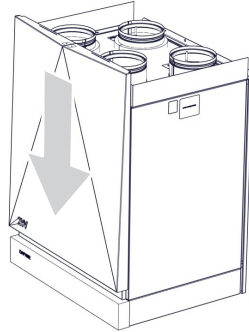

25.

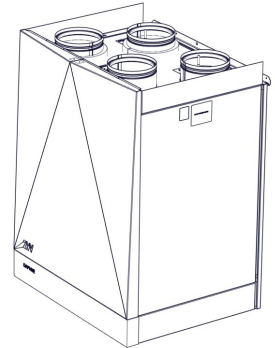

06 INSTALLATION

UNIT WITH COMFORT REGULATION:

The control is located on the bottom part of the unit. It can be fully removed for an easier connection of the control or other accessories.

ELECTRIC POWER DIAGRAM AND CONNECTION OF ACCESSORIES:

All phases of the electric power supply must be connected through the corresponding type of circuit breaker. The distance between disconnected contacts must be larger than 3 mm.

It must be possible to disconnect the unit from the electric power supply with a single power switch. Minimum size of the protective grounding cable must be in compliance with local safety regulations regarding heavy current lead through a device's protective grounding cable.

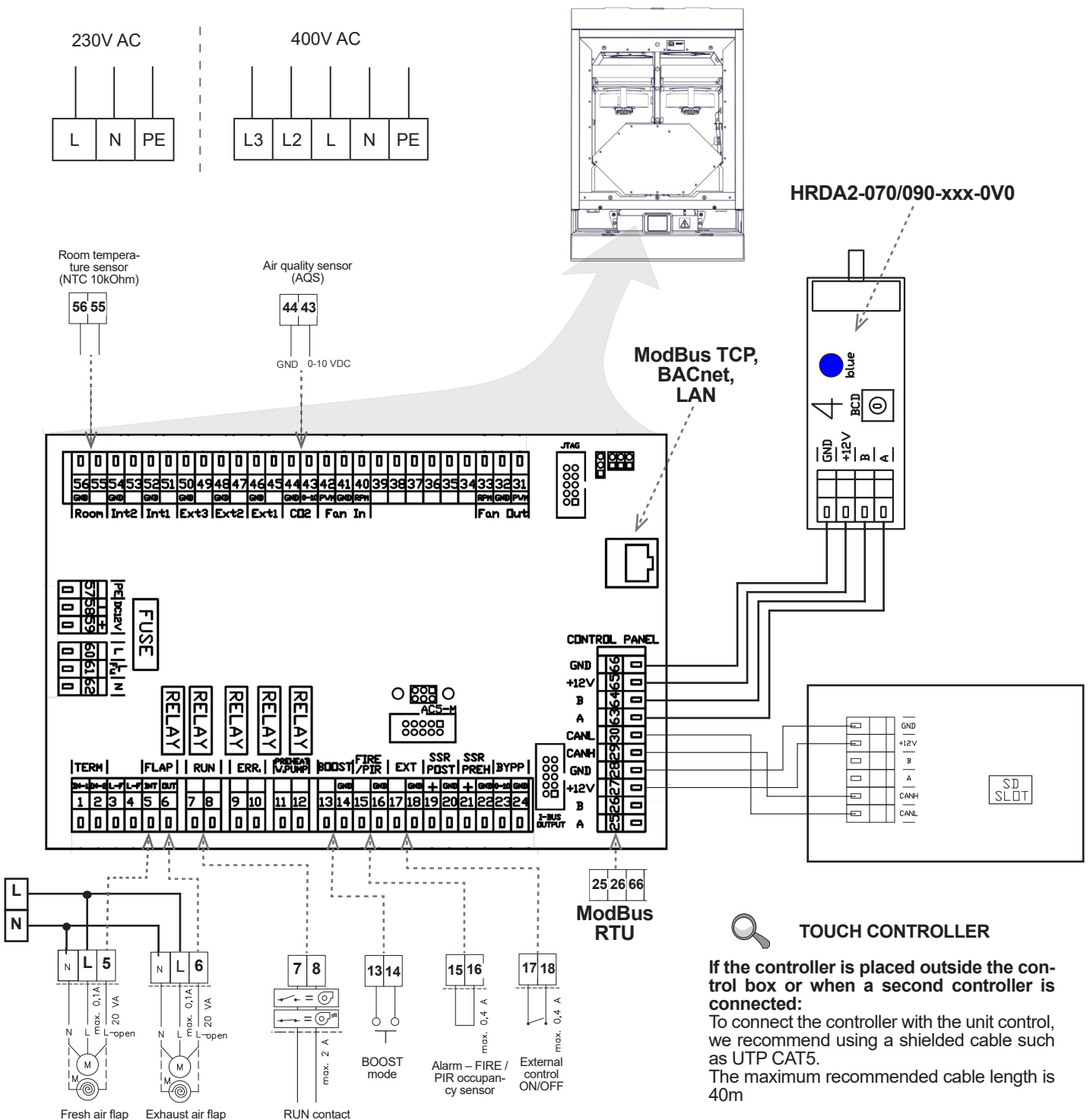

06 INSTALLATION

RECOMMENDED ACCESSORIES:

LM230 actuator + KRTK-A damper for supply and drain pipes.
It is always recommended to install these dampers.

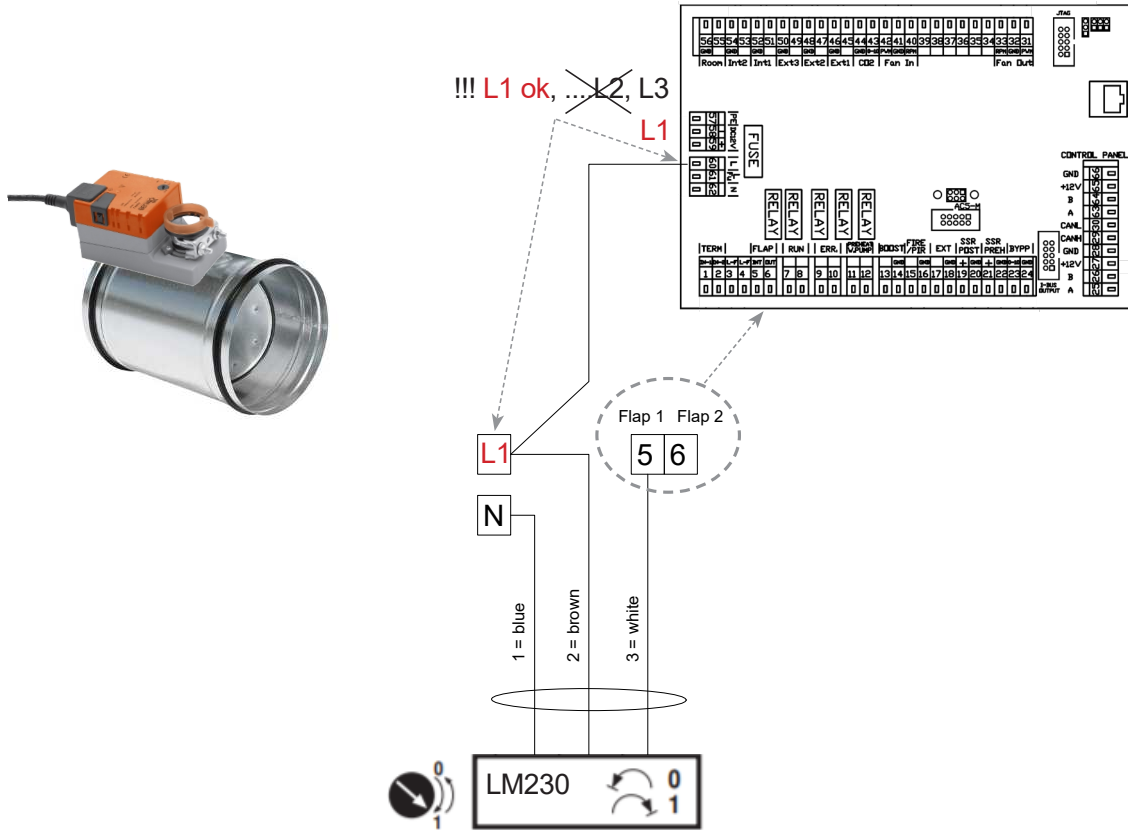

Check the following before switching on the unit for the first time:

- That the unit is properly closed and all the outlets are connected to the ductwork.
- That the electric connection matches the diagram, including earthing and protection of external circuits.
- That all the electric components are properly connected.
- That the condensate drain is connected to the sewage
- That the installation corresponds to the instructions in the manual.
- That no tools or objects that may damage the unit have been left inside.
- That the filters are clean

ATTENTION!

- Alterations and changes to the internal connections of the unit are forbidden and may result in the loss of warranty.
- We recommend the use of accessories provided by our company. Contact your supplier in case of doubts with the use of non-original accessories.

07 MAINTENANCE

REGULAR CLEANING OF THE UNIT

- We advise the unit be controlled at regular intervals adjusted depending on the current conditions.
- If the unit is out of service for a long period, it is advisable to turn it on for one hour at least every six months.

⚠ ATTENTION!

The service of internal components and the cleaning of the unit must be done only by a professional. It is forbidden to operate the unit without filters. It may damage the unit.

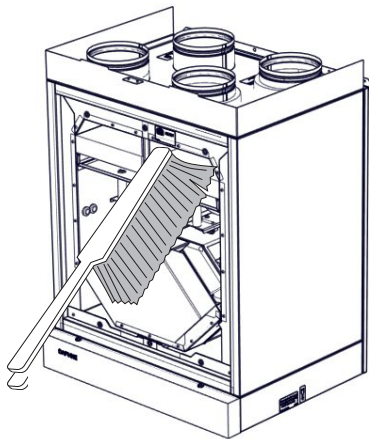

Clean the recuperation unit using a vacuum cleaner, small brush, cloth, and soapy water particularly the recuperator. Do not use the following product to clean the unit: Sharp objects, corrosive chemicals, solvents, abrasive cleaners, pressurized water, pressurized air or steam.

ERROR MESSAGES

Clogged filter

- The control of filter clogging is indicated on the unit remote.

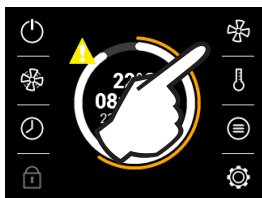

- After checking or replacing filters, the fouled filter control must be restarted; see the chapter MENU FILTER TIMER.

CHANGE FILTERS

1.

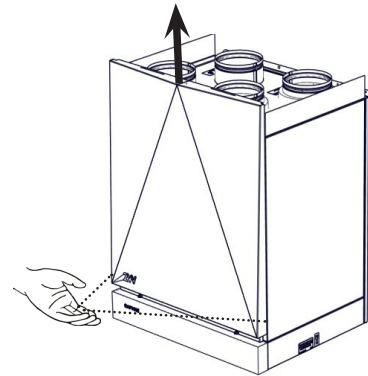

2.

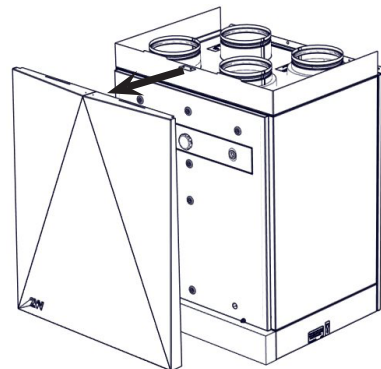

3.

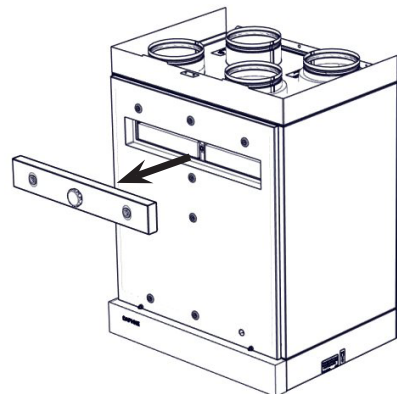

4.

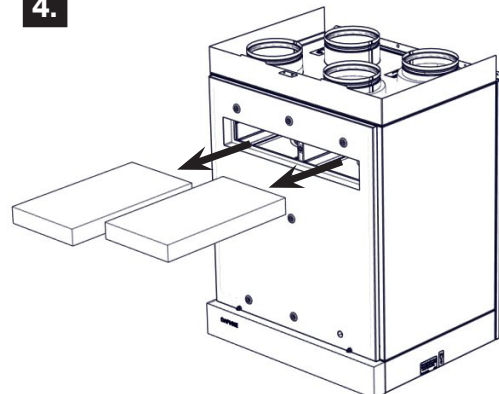

⚠ ATTENTION!

Failure to properly clean (change) the filters may reduce the performance of the unit and damage the fan.

08 TROUBLESHOOTING

REPAIRING OVERHEATED ELECTRIC PREHEATING AND AFTERHEATING

ATTENTION!

The service of internal components must be done only by a professional.
Always disconnect the unit before servicing.
Firstly, remove the cause of the overheated electric preheating and afterheating.

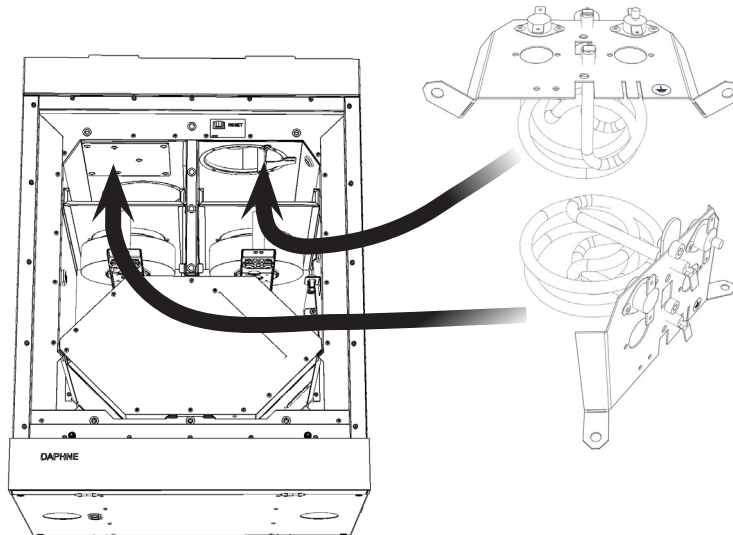

- For easier access to the electric preheating and reheating, the filters and fans can be removed.

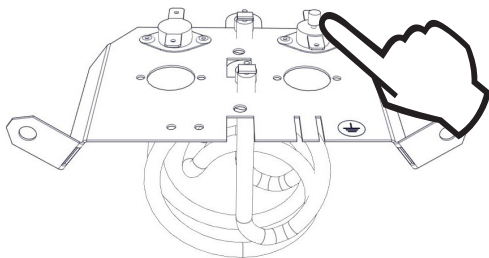

- The thermostat can be returned to the ON state pressing a button.



Disassembling the engine

Release the bracket from the set – square bit no. 2
Release the engine from the bracket – Allen bit no. 2.5

Printed circuit

Open boards with a flat screwdriver

Removing the boards from the plastic frame – pliers for precision mechanics

Releasing the printed circuit – Philips screw no. 0

Plastic parts

Ceiling insulation of front panels – box cutter



Once the it has been installed, read carefully the safe operation manual of the unit. That manual includes examples of possible problems and recommended solutions. In case of any requests or inquiries, contact our sales or technical department.

Contact

Address

2VV, s.r.o.
Nádražní 794
553 51 Pardubice – Rosice
Czech Republic

Website:

<http://www.2vv.cz/>

