

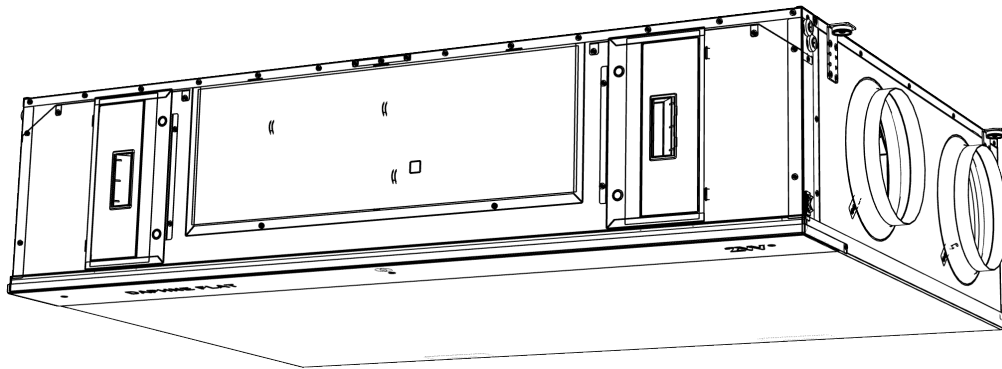

PARTNER  
IN VENTILATION  
2VV.CZ

EN

# DAPHNE FLAT







**INSTALLATION**

**CE EAC**

1. BEFORE STARTING	3
2. UNPACKING	4
3. MAIN COMPONENTS	5
4. DIMENSIONS	6
5. TECHNICAL PARAMETERS	7
6. INSTALLATION	8
7. COMMISSIONING	19
8. MAINTENANCE	20
9. TROUBLESHOOTING	21
10. LIQUIDATION PROCEEDINGS	24
11. CONCLUSIONS	25

# 1. BEFORE STARTING

For better orientation, the following symbols can be found in the text of the instruction manual. The following table describes the symbols and their meaning.

SYMBOL	MEANING
 <b>ATTENTION!</b>	Warning or notice
 <b>READ CAREFULLY!</b>	Important instructions
 <b>YOU WILL NEED</b>	Practical tips and information
 <b>TECHNICAL DATA</b>	Detailed technical information
	Reference to another point/section of the manual



Before installing the unit, **read carefully the section on the safe operation of the heat recovery unit**. You will find instructions on the safe and proper use of the product.

This manual provides instructions on how to properly install the unit. Before installing the unit, read carefully the entire manual. The manufacturer reserves the right to make changes, including in the technical documentation, without prior notice. Keep the manual in a safe place for future reference. The manual is an integral part of the product.

## Declaration of conformity

The product has been designed, produced and marketed in compliance with all the applicable provisions, and abides to the provisions of the European Parliament and Council, including the amendments under which it has been classified. It is safe under normal conditions and under the conditions laid down by the manual. The assessment was conducted pursuant to harmonized European standards included in the relevant EC Declaration of Conformity. The current and full version of the EC Declaration of Conformity can be found at [www.2vv.cz](http://www.2vv.cz)

## 2. UNPACKING

### 2.1 PLEASE CHECK THE DELIVERED PRODUCT

#### PLEASE NOTE

- Check immediately on delivery, that the packaged product is not damaged. In the event of damaged packaging, consult the haulier.
- In the event that any reclaim will not be applied in time, future applications will not be processed.
- Check if the product type is the one you have ordered. In the event that it is not the ordered unit, do not open the packaging and report the fault to the supplier immediately.
- After unpacking the product, check that the units and accessories are in order. If you have any doubts, contact the supplier.
- Never try to operate a damaged ventilation unit.
- In the event that you decide not to unpack the ventilation unit immediately after delivery, the product must be stored in a dry interior with a temperature ranging from
- +5 °C up to +40 °C maximum.
- This product is not intended for use by persons (including children) whose physical, sensory or mental incapacity or lack of experience and knowledge in the safe use of products when they are not supervised or, if they were not instructed on the use of the product by a person responsible for their safety.
- Children should be supervised to ensure that they do not play with the unit.

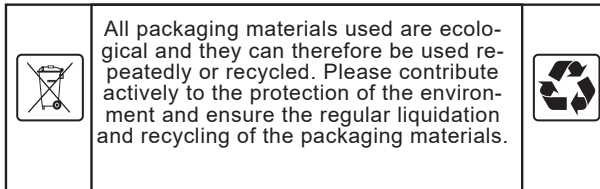
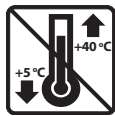

### 2.2 UNPACKING THE UNIT

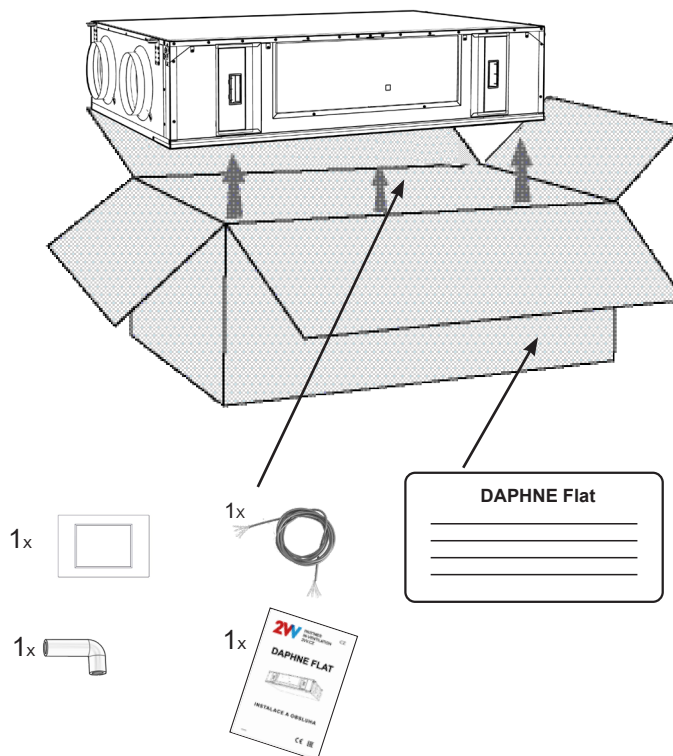

#### PLEASE NOTE!

*If the unit was shipped at below 0°C temperatures, let it rest for at least 2 hours, without turning it on, so that its inner temperature can match the surroundings.*

### 3. MAIN COMPONENTS

HRDF1 - 030 / 050 / 070

**RIGHT VERSION**  
Bottom view

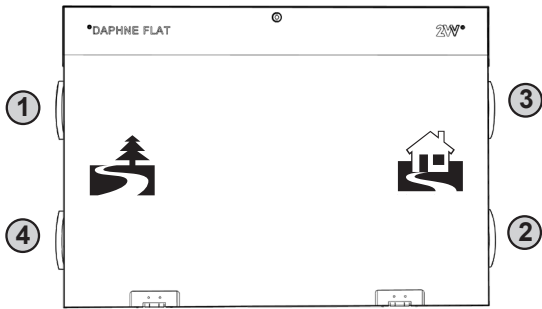

**LEFT VERSION**  
Bottom view

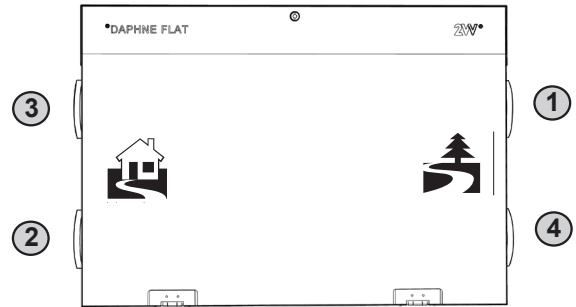

- ① Duct connection - outdoor air (ODA)
- ② Duct connection - supply air (SUP)
- ③ Duct connection - diverted air (ETA)
- ④ Duct connection - exhaust air (EHA)

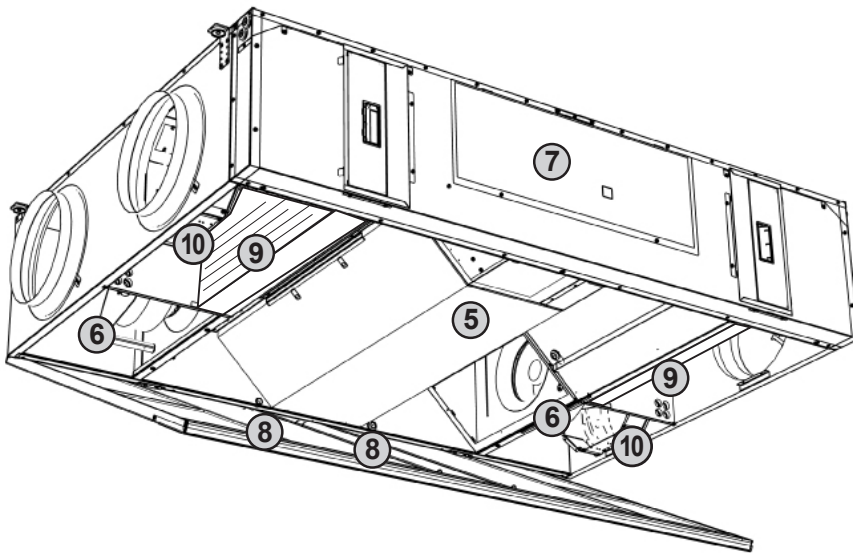

- ⑤ Heat exchanger with by-pass
- ⑥ Fans
- ⑦ Regulation unit - connecting power and accessories
- ⑧ Condensate drain
- ⑨ Filters
- ⑩ Electric heating

# 4. DIMENSIONS

HRDF1 - 030 / 050 / 070

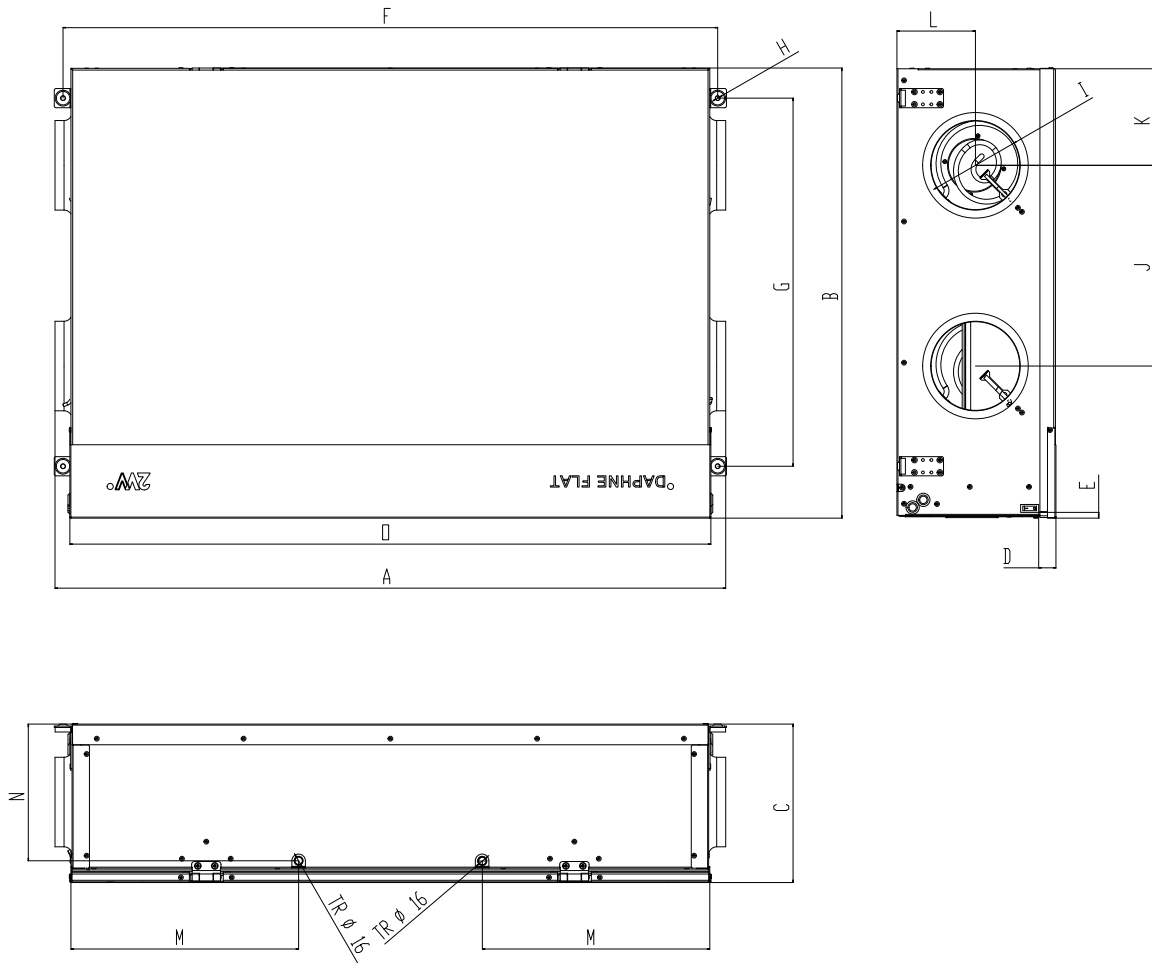

	A (MM)	O (MM)	B (MM)	C (MM)	D (MM)	E (MM)	F (MM)	G (MM)	H (MM)	I (MM)	J (MM)	K (MM)	L (MM)	M (MM)	N (MM)
HRDF1-030	1188	1135,5	797	281,5	30,5	10	1160	652	Ø8	Ø160	355,5	171	139	403	242
HRDF1-050	1432	1347,5	885	322,5	30,5	10	1380	702	Ø8	Ø200	400,5	195	157	517	285
HRDF1-070	1646	1547,5	1065	364,5	30,5	10	1580	902	Ø8	Ø250	508	228	180	619	326

## 5. TECHNICAL PARAMETERS

Type without electric pre-heater and post-heater

Type	Voltage [V]	Frequency [Hz]	Power [kW]	Total current [A]
HRDF-030	230	50/60	0,2	2
HRDF-050	230	50/60	0,2	2
HRDF-070	230	50/60	0,35	2,6

Type with electric pre-heater without post-heater

Type	Voltage [V]	Frequency [Hz]	Power [kW]	Total current [A]
HRDF-030	230	50/60	1,4	7,3
HRDF-050	230	50/60	2,2	10,7
HRDF-070	230	50/60	2,7	13

Type with electric pre-heater and post-heater

Type	Voltage [V]	Frequency [Hz]	Power [kW]	Total current [A]
HRDF-030	230	50/60	2,6	12,6
HRDF-050	230	50/60	3	14,2
HRDF-070	400	50/60	4	10,4

Characteristics of electric motors (1 Fan only)

Type	Voltage [V]	Frequency [Hz]	Power [kW]	Total current [A]	Speed [r/min]	IP	Insulation class
HRDF-030	230	50/60	120	0,87	3270	44	B
HRDF-050	230	50/60	165	1,25	2530	44	B
HRDF-070	230	50/60	455	2,8	2600	54	B

Characteristics of electric pre-heater

Type	Power [kW]	$\Delta T$ (°C)
HRDF-030	1,2	12
HRDF-050	2	12
HRDF-070	2,4	10,3

Characteristics of electric post-heater

Type	Power [kW]	$\Delta T$ (°C)
HRDF-030	1,2	12
HRDF-050	0,8	4,8
HRDF-070	1,2	5,1

## 6. INSTALLATION

### 6.1 CHOOSING THE PLACE

**It is recommended that installation of a ventilation system be prepared by an HVAC designer**



#### TECHNICAL INFORMATION



The unit is designed to be operated in a dry indoor environment (relative humidity not exceeding 80%) and at an ambient temperature in the range from +5°C up to +40°C.

The unit is designed for transporting standard atmospheric air that is free of dust, grease, chemical emissions and other impurities.

Fresh intake air should have a temperature ranging from -20°C to +40°C and relative humidity of up to 90%.

**CONDITIONS OF USE OF THE ENTHALPY EXCHANGER:** if the outside temperature does not drop below -5°C, the indoor relative humidity is less than 45%, the indoor temperature is up to 23°C so there is no need for condensate drainage. In case of other conditions such as lower outdoor temperature or higher indoor temperature or higher indoor humidity, a condensate drain must be installed.

#### Condensation within the unit:

If the unit is placed in an attic space (temperatures may approximate outdoor temperatures), it is necessary for the unit to run continuously. If the unit can be turned off manually by the user or an automatic timer, it is necessary to install airtight dampers with emergency functioning on the intake and exhaust ducts. The dampers will ensure that no air from the warm parts of the building will flow through the unit (stack effect). If no dampers have been installed, there will be a risk of condensation within the unit and exterior ducts at the time the unit is deactivated. This may also result in cold exterior air flowing into the building. In that case condensation can also occur within the intake and exhaust ducts or even in valves placed in rooms. If the unit is not running for a long period of time during winter, the intake and exhaust ducts should be closed so that the above effect does not occur after this period. If the unit is placed in a moist area (e.g. a laundry room), condensation on the external parts of the unit may occur when combined with low exterior temperatures. If condensation occurs outside the unit, increase the ventilation in the surroundings of the unit.

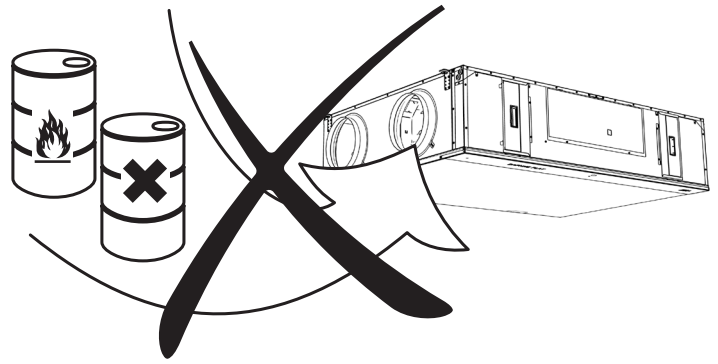
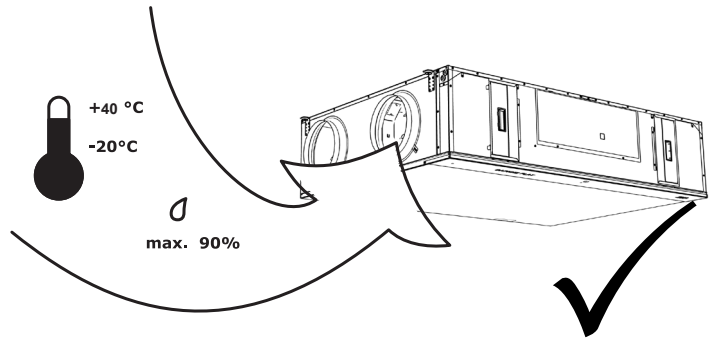
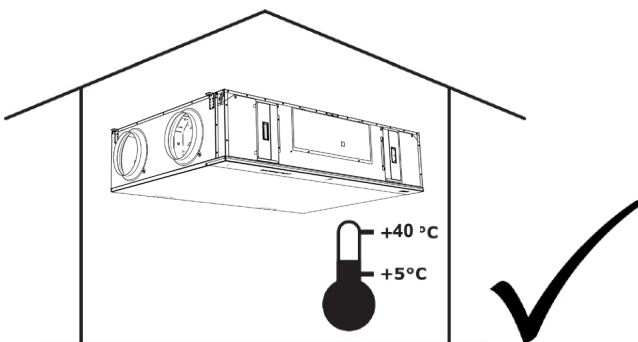

The unit is not designed to filter air containing combustible or flammable particles, chemical fumes, coarse dust, carbon, grease, poisons, bacteria, etc.

The IP protection level of the unit in the ducts is IP 20

## 6. INSTALLATION

### 6.1-1 Installation distance

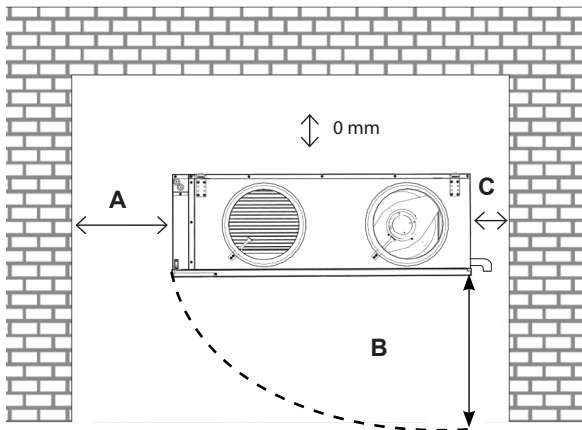

These dimensions are recommended for servicing access.

	A	B	C
HRDF1-030	min. 450 mm	min. 850 mm	min. 150 mm
HRDF1-050	min. 500 mm	min. 950 mm	min. 150 mm
HRDF1-007	min. 600 mm	min. 1150 mm	min. 150 mm

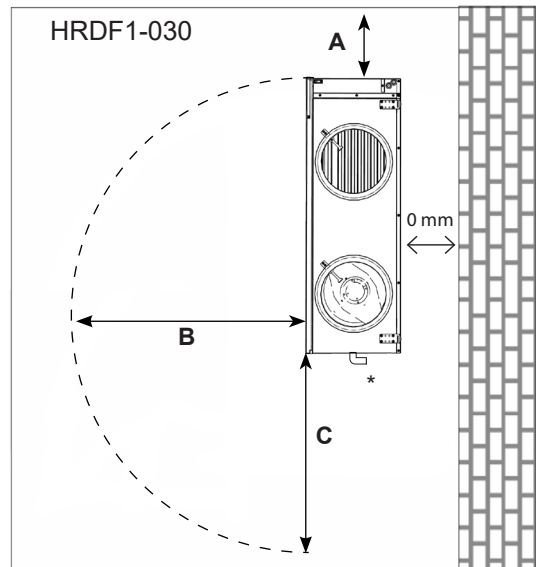

Installation on the wall possible only for HRDF1-030

\* The unit can only be installed in a position where the condensate drain is pointing downwards.

These dimensions are recommended for servicing access.

	A	B	C
HRDF1-030	min. 450 mm	min. 850 mm	min. 850 mm
HRDF1-050	no possible	no possible	no possible
HRDF1-007	no possible	no possible	no possible

## 6. INSTALLATION

### TECHNICAL INFORMATION

- All models of the heat recovery unit can be installed in the following positions:

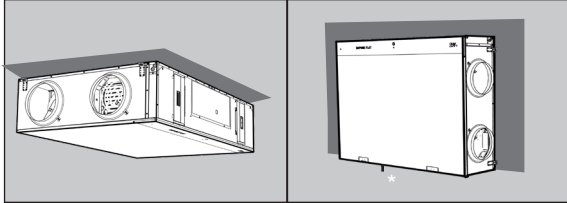

\* Installation on the wall possible only for HRDF1-030



\* The unit can only be installed in a position where the condensate drain is pointing downwards.

- Any other position is forbidden.

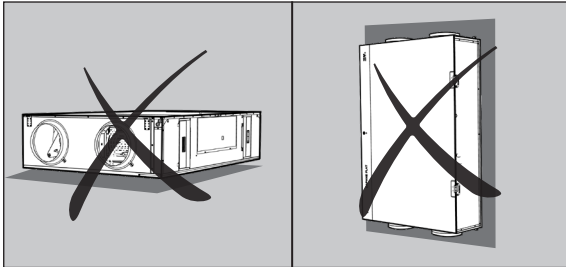

- The unit must be installed so that the direction of the air exhaust corresponds to that of the distribution system.
- The unit should be installed so as to provide access for maintenance, service or disassembly. This includes, in particular, access to inspecting the dampers flaps and their opening, access to the cover of the control unit's cabinet, to the cover of the of the air filter.

#### 6.1-2 Safe installation distance

#### ⚠ ATTENTION!

- All the materials within a distance of 100 mm of the unit must be non-flammable (they don't burn or flare) or of low flammability (they don't burn, disintegrate, like plasterboard). These materials, however, must not cover the unit's inlet and exhaust openings.
- The safe distance between combustible materials and the exhaust is 500 mm.
- The safe distance for combustible materials in all directions is 100 mm.

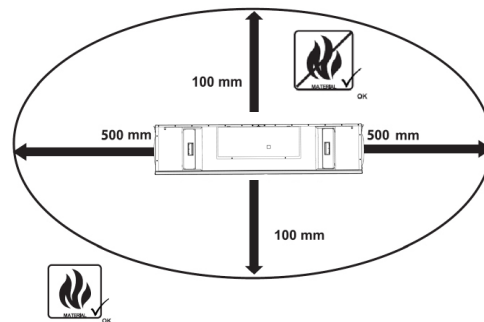
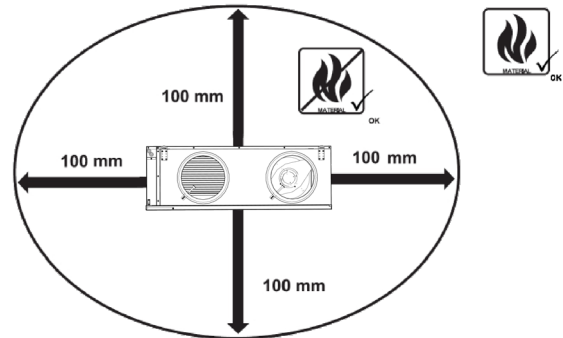

#### 6.1-3 Hanging the unit

Use the drilling template below to place the anchoring points.

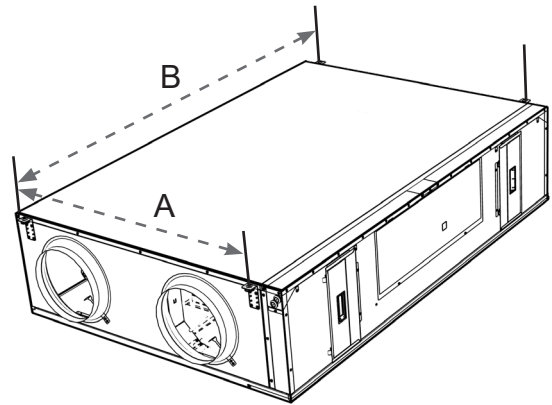

Type	A	B
HRDF1-030	652	1160
HRDF1-050	702	1380
HRDF1-070	902	1580

Type	Weight of unit (kg)		
	Without heating	With electric pre-heating	With electric pre-heating and post-heater
HRDF1-030	62	63	64
HRDF1-050	81	82,5	84
HRDF1-070	100	102	104

## 6. INSTALLATION

Drill the holes in the ceiling / on the wall, check the strength of the material and fasten the unit to the side brackets with the ZTZ-M8/1,0 threaded rods.

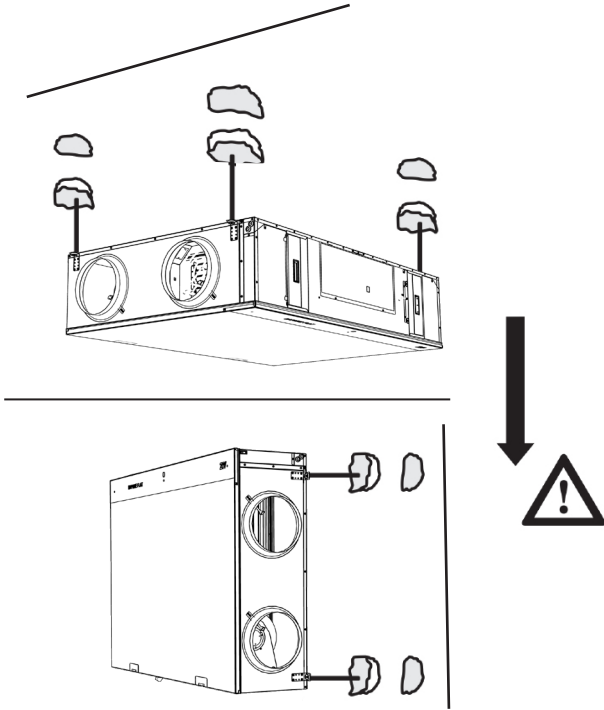

### **⚠ ATTENTION!**

- The support of the unit should be sufficiently strong, it must correspond to the unit's weight!
- Given its weight, lifting equipment will be required when installing the unit (e.g. a forklift) or at least two more people to hold it.

### Underfloor installation

Place the unit horizontally and then tilt it 3° to drain the condensate.

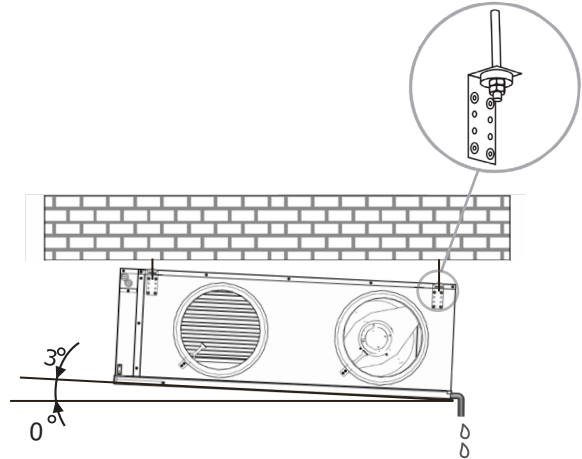

### Installation on the wall

When installing on the wall, place the unit horizontally. The unit can only be installed in a position where the condensate drain is pointing downwards.

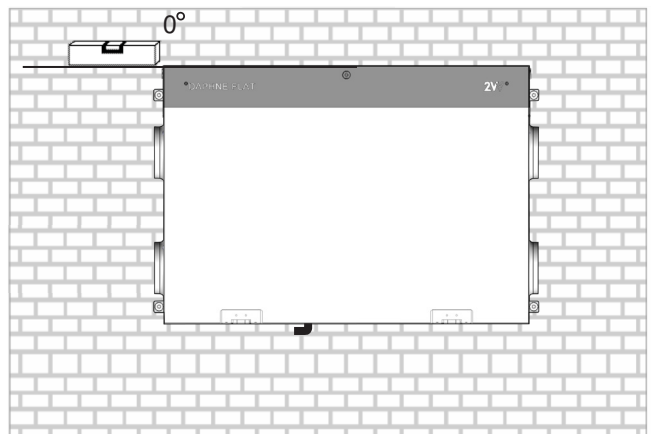
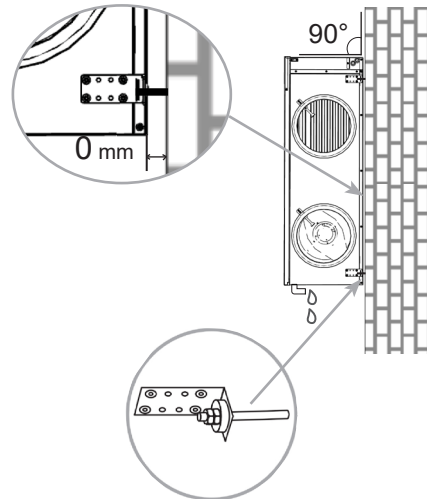

## 6. INSTALLATION

### 6.2 CONNECTING HVAC DUCTS

#### READ CAREFULLY!

- The connected ductwork must have the same dimensions as the intake and exhaust openings of the unit. Ducts of a smaller diameter may reduce the efficiency of the unit and, in some cases, also its lifespan.
- Connect the intake and exhaust openings (rectangular/circular opening) with flexible joints in order to reduce vibrations.

All the connections to the ductwork must be sealed with sealant or tape.

The minimum distance between bends in the ductwork or adapters and the neck of the unit is 500 mm.

#### 6.2.-1 Flexible connection

Connect the ducts to the exhaust and the suppl collars using flexible connections to stop the transfer of vibrations it will allow easier removal of the unit from the installation place when servicing.

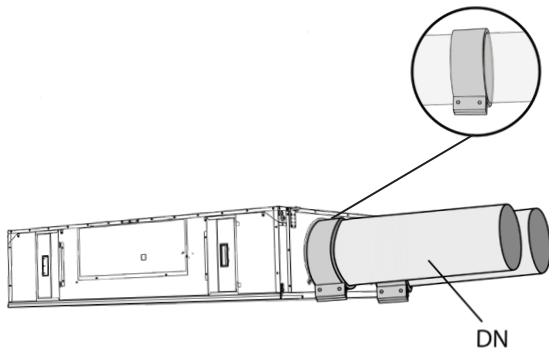

Typ	DN
HRDF1-030	Ø160
HRDF1-050	Ø200
HRDF1-070	Ø250

#### 6.2-2 Protective screen

In the event that some of the collars of the unit will not be used for connecting ducts, it is necessary to fix the opening with a screen for protection from touching the rotating parts of ventilator, heater bars etc.

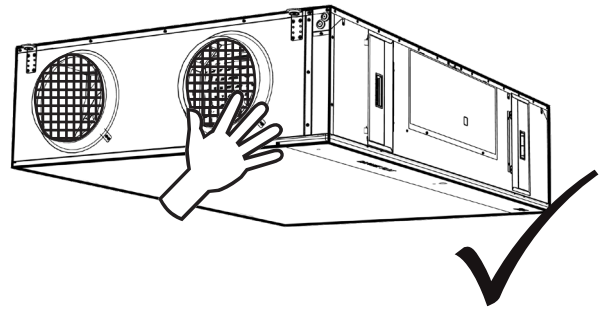
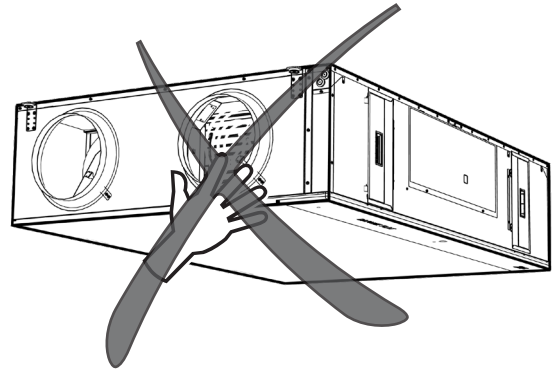

#### 6.2-3 INSTALLATION OF A FILTER BOX IN THE DUCT

If unit is equipped with preheating, then it is necessary to install in the outside air duct (ODA) a filter box of type FLF-A or FLK-B. This will prevent air pollution and the ingress of dirt on the electric heating element.

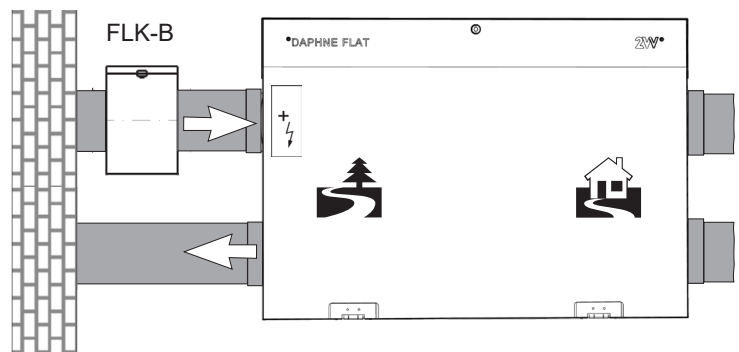

## 6. INSTALLATION

### 6.3 CONNECTING THE CONDENSATE DRAIN

- The siphon must have a quality connection and sealed to the recuperation unit.
- We recommend to submerge each siphon in water to check its integrity.

#### ATTENTION

**Improper connection of the siphon may cause flooding and damage to the heat exchange unit.**

#### INSTALLATION OF THE RECOMMENDED TYPE:

Siphon SK-HL138  
It can be installed on a wall or concealed.  
(not included)

#### 6.3-1 Ceiling installation

- Check whether the unit is tilted so the condensate may run off freely (we suggest 3° tilt, see the figure below).

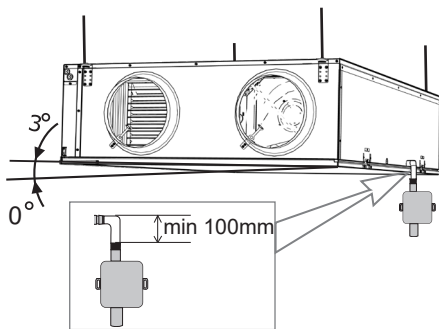

#### 6.3-2 Installation on the wall

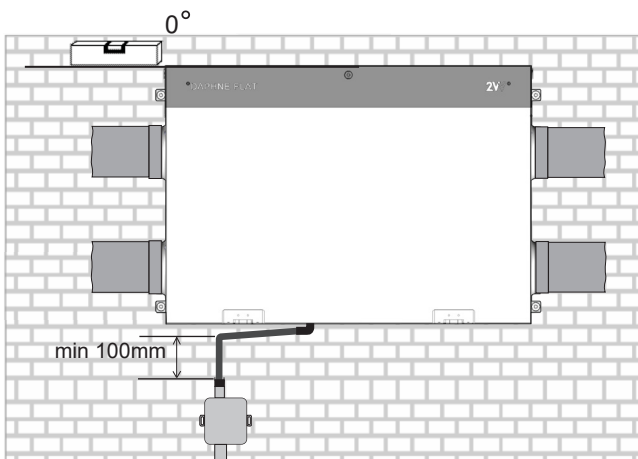

The unit is equipped to connect a second condensate drain in places where summer conditions require it. This second condensate drain must be connected when the dew point temperature of the inside air is lower than the outdoor air coming into the building. These situations may occur, especially in hot summer, when the high temperature and humidity of the outside air crosses the low temperature exhaust air inside the heat recovery core (e.g., + 25 ° c and + 35 ° c between the inside air and the outside air, with a relative humidity above 60%). Therefore, we recommend that you install a second (during summer) condensate drain especially for chilled air conditioning buildings located in tropical climates.

The second condensate drain properly connect to the drain pipe. **Improper connection of the siphon may cause flooding and damage to the heat exchange unit.**

#### CONDENSATE DRAIN CONNECTION FOR THE RIGHTVERSION (View of the bottom of the unit)

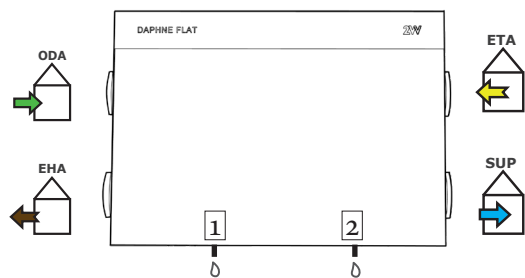

#### CONDENSATE DRAIN CONNECTION FOR THE LEFT VERSION (View of the bottom of the unit)

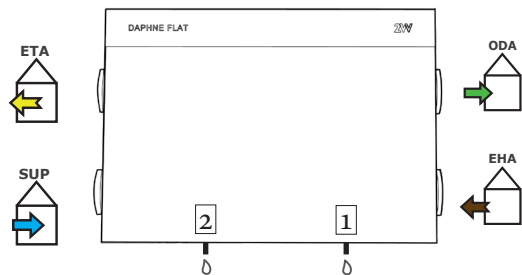

- 1) Condensate drain connection for winter period- must always be connected.
- 2) Connection of the second condensate drain for the summer period (the drain is blinded by a blanking plug)- connected according to the conditions.

## 6. INSTALLATION

### 6.4. CONNECTING THE WIRING AND ELECTRICAL ACCESSORIES

#### **ATTENTION!**

- The main power switch must be turned off before any intervention on the unit!
- The electrical connection must be done by a qualified person (electrician). The electrical connection may be done only by a person authorised for such tasks. All the instructions herein and the local regulations must be observed.
- The wiring diagram on the product take precedence over the diagrams included herein! Before connecting, make sure that the terminal markings correspond to the diagram. In case of doubt, do not connect the unit and contact the supplier.
- If the unit is connected to a control system other than the original, contact that system's supplier regarding the connection of measuring sensors and control components.
- The unit must be connected to the mains with a temperature resistant, rigid, insulated cable that complies with the local regulations.
- Any intervention or modifications to the internal electrical connection are forbidden and shall result on loss of warranty.
- The correct operation of the unit can be guaranteed only with the use of original accessories.
- Should it be necessary to install a sensor or control device in the unit or its cover, consult with the manufacturer or their representative.

#### 6.4-1 Power cord

The terminal strip for the power cable is located in the housing of the control device.

#### **ATTENTION!**

The minimum dimensions of the safety grounding conductor must conform with the applicable local regulations.

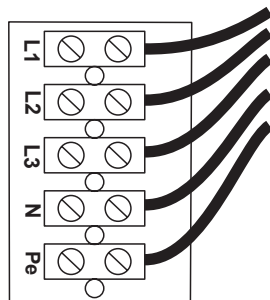

#### TECHNICAL INFORMATION

- The parameters of the wiring can be found on the label located on housing of the control device.

Label with the type of unit

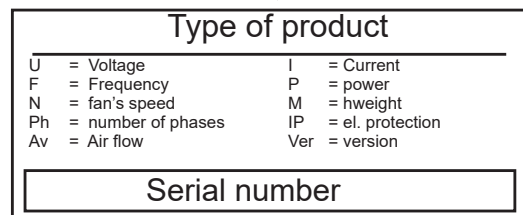
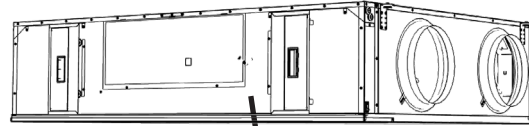

All phases of the electric power supply must be connected through the corresponding type of circuit breaker. It must be possible to disconnect the unit from the electric power supply with a single power switch.

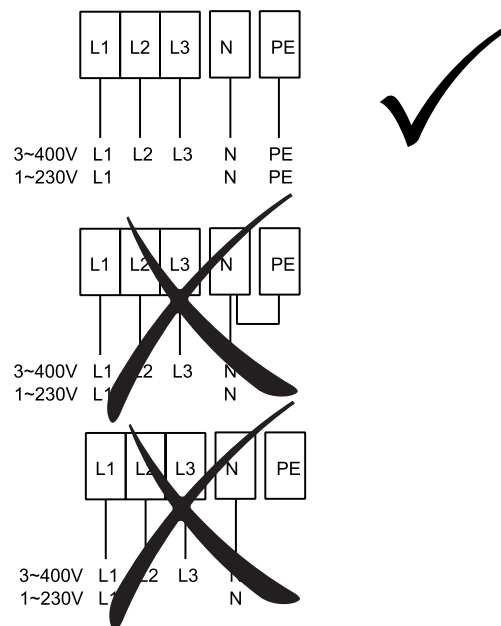

## 6. INSTALLATION

The unit must be connected with a TN-S system, meaning that the neutral conductor must be always connected.

All the phases of the power supply must be connected through the appropriate type of circuit breaker. The distance between open contacts must be greater than 3 mm.

The unit must be connected in a way that it may be disconnected from the power supply with a single switch.

### Recommended breakers:

HRDF1-030... XS0C	2A, 1ph
HRDF1-030... ES0C	8A, 1ph
HRDF1-030... EE1C	13A, 1ph
HRDF1-050... XS0C	2A, 1ph
HRDF1-050... ES0C	13A, 1ph
HRDF1-050... EE1C	16A, 1ph
HRDF1-070... XS0C	3A, 1ph
HRDF1-070... ES0C	16A, 1ph
HRDF1-070... EE1C	8A, 3ph

### 6.5-1 Electrical fittings

Connect the unit electrical fittings to the terminal inside the regulator box exactly according to the el. diagram for connection and according to the markings of the terminals.

#### **DO NOT MISS!**

- The connection diagram is glued to the internal side of the removable lid of the regulator box.
- Each element must be connected using an original cable or cable as per the specification for each element.
- To open the lid of the regulator box you will need TORX22 key. See picture.

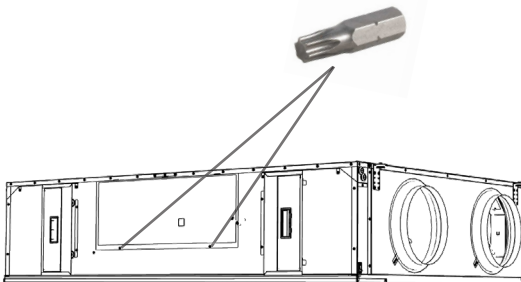

After unscrewing the screw, remove the cover.

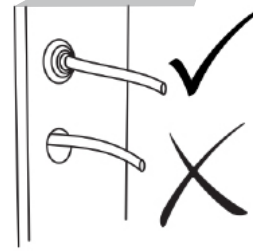
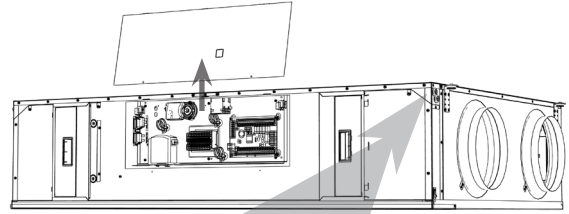

230V AC



400V AC

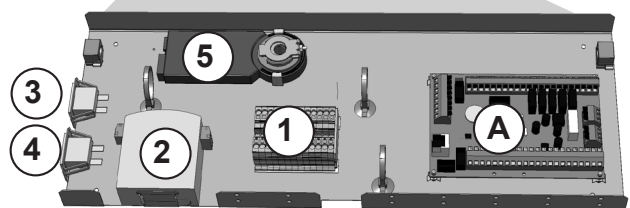
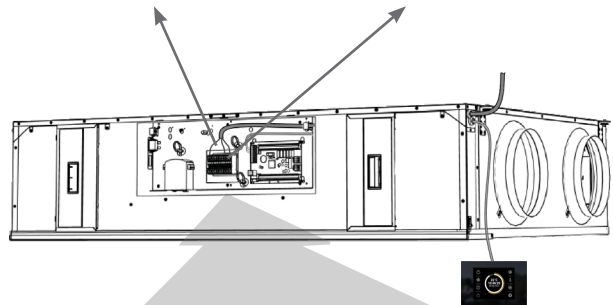
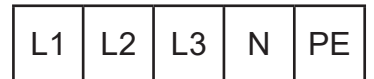

A	Electronics board - module A
1	Terminal block for power supply (L), connection of N and PE cables and output of auxiliary power supply (24V)
2	The power supply (12V, 24V)
3	Engine fuse
4	Fuse for accessories
5	Servo drive by-pass

# 6. INSTALLATION

## ELECTRIC SCHEME FOR ACCESSORIES CONNECTION

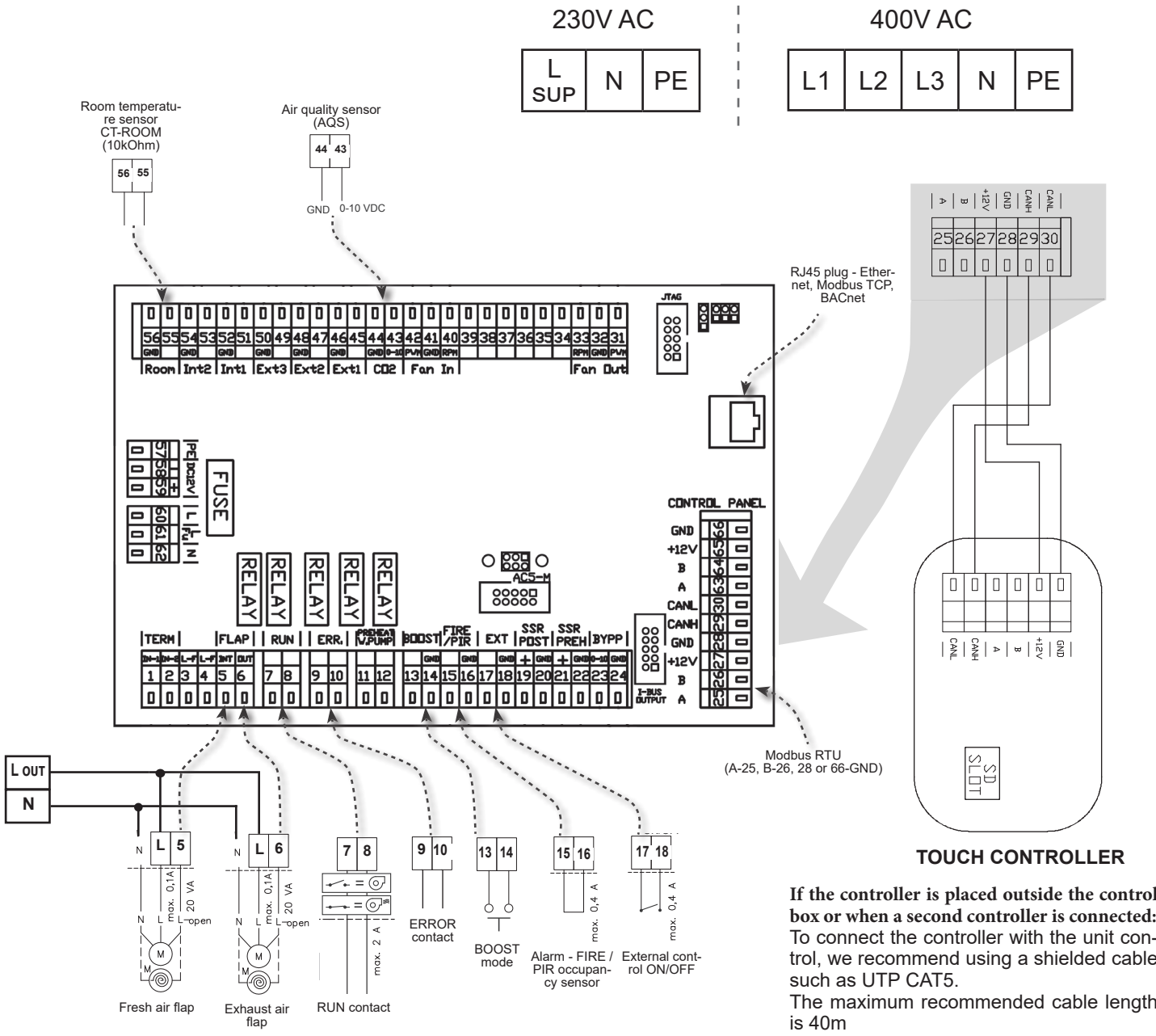

**If the controller is placed outside the control box or when a second controller is connected:** To connect the controller with the unit control, we recommend using a shielded cable such as UTP CAT5. The maximum recommended cable length is 40m

## 6. INSTALLATION

### 6.5-2.1 External control

#### TECHNICAL DATA

- Low voltage switching contact - maximum possible contact load 12 V, 0.4 A.
- CABLE: Cable with two conductors of cross section min. 0.5 mm<sup>2</sup> Maximum length 50 m.
- The contact is normally closed. When the contacts open, the unit turns off. This setting can be changed in the service menu 1616

### 6.5-2.2 Fire contact

#### TECHNICAL DATA

- Low voltage switching contact - maximum possible contact load 12 V, 0.4 A.
- CABLE: Cable with two conductors of cross section min. 0.5 mm<sup>2</sup> Maximum length 50 m.
- The contact is normally closed. When the contact disconnects, the unit operates according to the settings.

### 6.5-2.3 Actuator to close the air supply regulator with a spring (accessory)

#### TECHNICAL DATA

- The actuator is supplied by 230 V AC – control with a cable with three conductors
- CABLE: cable with three conductors of a cross section min. 0.5 mm<sup>2</sup>. Maximum length 50 m.

Not included!

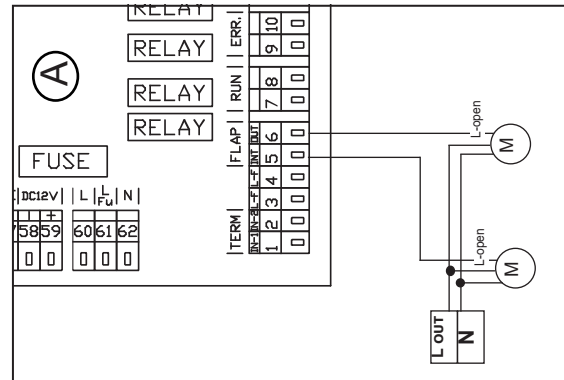
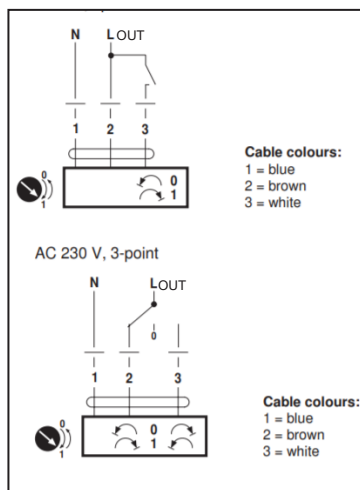

### 6.5-2.4 CO<sub>2</sub> / RH room sensor

#### AirGENIO comfort regulation: Automatically control unit with external sensors

##### • CO<sub>2</sub> room sensor

CI-CO<sub>2</sub>-R - CO<sub>2</sub> sensor used in automatic mode for activating/deactivating the unit according to the level of CO<sub>2</sub> in the air. Limit values must be set for the sensor.

##### • Relative humidity room sensor

CI-RH-R - RH sensor used in automatic mode for activating/deactivating the unit according to the level of relative humidity in the air. Limit values must be set for the sensor.

#### PLEASE NOTE!

- The accessories must be powered with their own external supply.
- For details on the power supply, refer to the documentation of the given accessory.

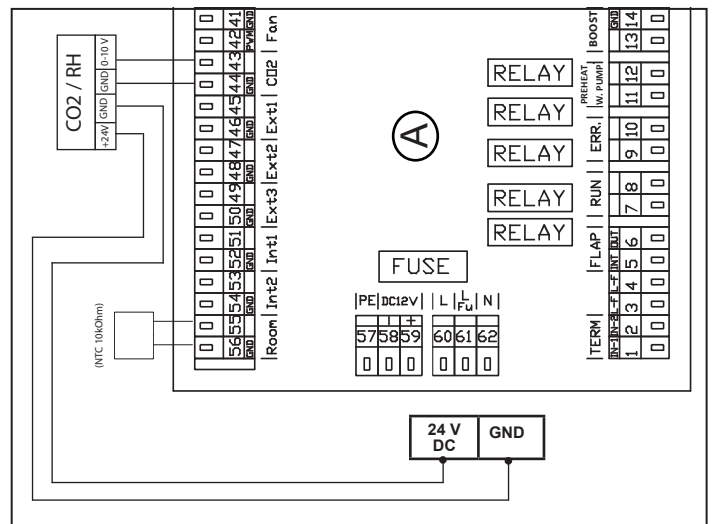

## 6. INSTALLATION

### 6.5-2.5 Movement sensor

Low voltage switching contact - maximum possible contact load 12 V, 0.4 A.

CABLE: Cable with two conductors of cross section min. 0.5 mm<sup>2</sup> Maximum length 50 m. The contact is normally open. When the contact closes, the unit operates according to the ventilation rate settings.

### 6.5-3 Control unit

To start the unit, connect the remote control to the unit with the control cable (UTP).

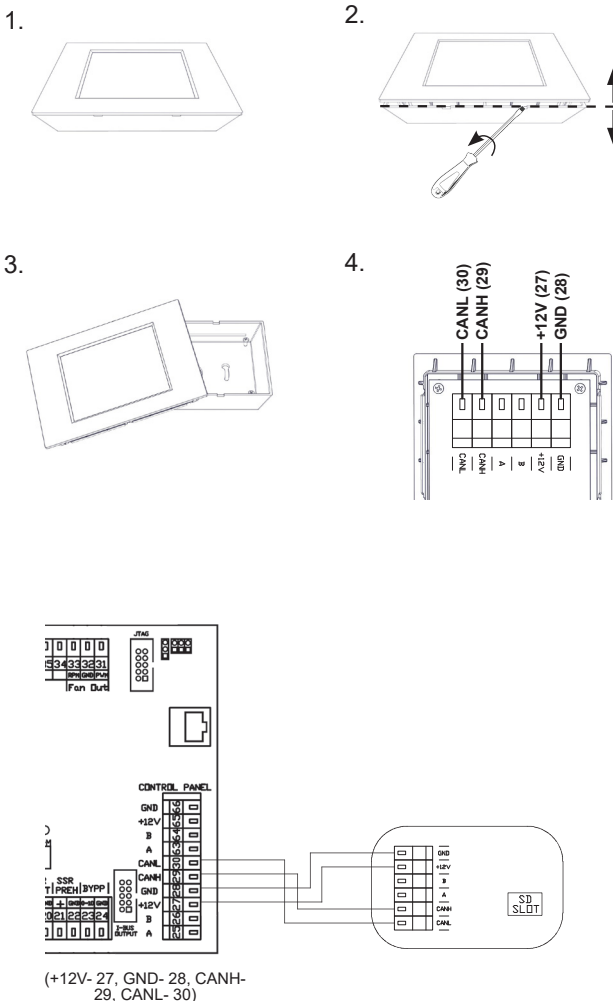

### 🔍 READ CAREFULLY!

- There should be as much distance as possible between the supply and control cables.
- Make sure that the cable snaps into the connector.
- Be careful not to damage the cable insulation when fitting the control to a wall or other surface.
- If the connectors and cables aren't connected immediately after installing the unit, protect them with insulating tape against mechanical damage or short-circuit.
- The cable connectors must not come into contact with water or any other liquid.

### 6.5-4 Connecting the unit to a BMS control system

The control of the unit is fitted with a RS-485 and an RJ45 interface as standard. Insert the cable into one of the connectors on the unit's electronic board. Connect the other end to the main control unit. For protocol details (Modbus-TCP, Modbus-RTU), contact 2VV.

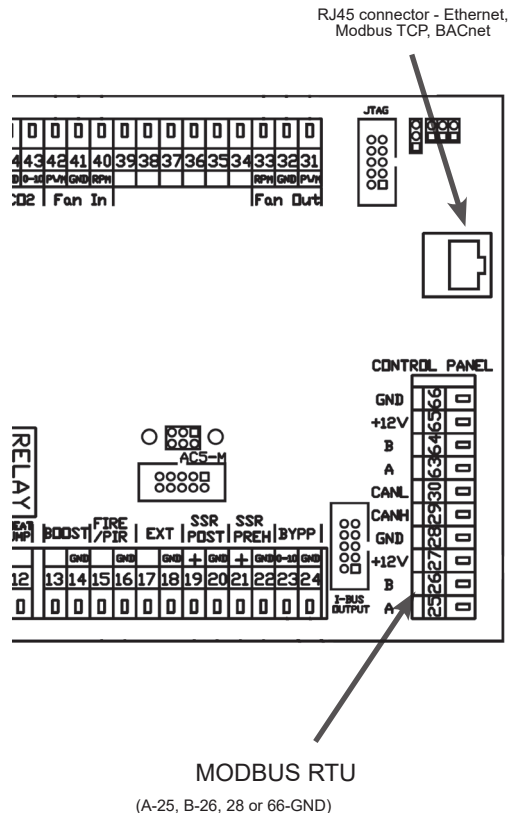

## 7. COMMISSIONING

### **READ CAREFULLY!**

Before the initial commissioning, check:

- that the unit is properly fastened to the supporting structure
- that the unit is properly closed and that all collars are connected to ducts or are fitted with rain blinds to prevent water from coming into contact with any moving or heating parts.
- that the wiring is well connected, including earthing and protection against external start-up.
- that all the accessories are well connected.
- that the condensate drain is well connected to the drainage piping (units with cooling).
- that the connection complies with the instructions herein.
- that no tools or other objects have been left inside the unit – it could result damage.

### **CAUTION!**

- Any intervention or modifications to the internal connection are forbidden and shall result on loss of warranty.
- We recommend using the accessories we supply. In case of doubt regarding the use non-original accessories, contact 2VV.

## ACTIVATION

To activate the unit (Stand by mode), it is necessary to turn the main switch on (position I). After activation, the display on the control panel lights up and data download will start. After complete download of these data, the unit is ready for operation.

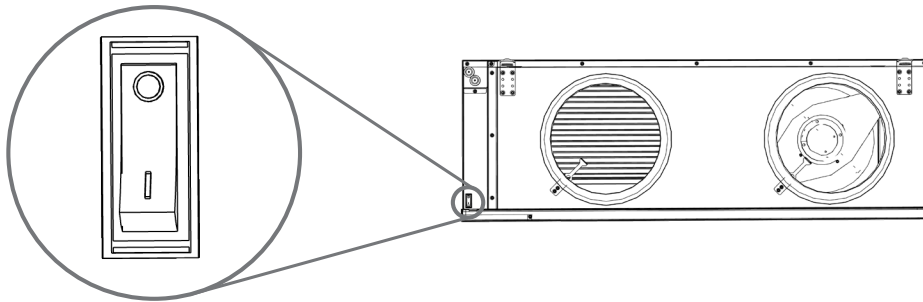

## 8. MAINTENANCE

### 8.1 FILTER CHANGE

After the set filter clogging check period has expired, the controller displays a warning about the need to check or replace the air filter.

**⚠ ATTENTION!**

If the filters are not changed properly, the heat recovery unit may be damaged.

The filter can be replaced from the side or by opening the bottom cover.

- a) replacing the filter from the side
- open the air filter cover (side cover held by magnet)
  - replace filters

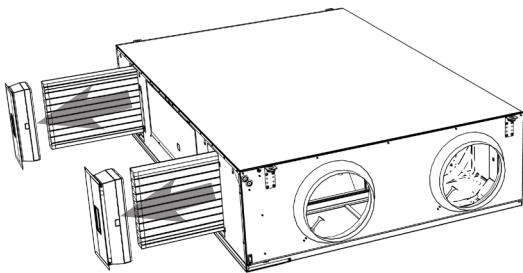

- b) replacing the filter from the bottom cover
- open the designer cover

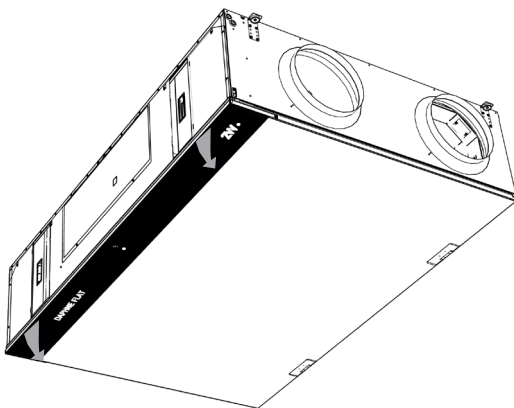

- unscrew the screws

**⚠ The cover is not secured by a fall protection system. When removing the screws, hold the cover to prevent it from opening freely.**

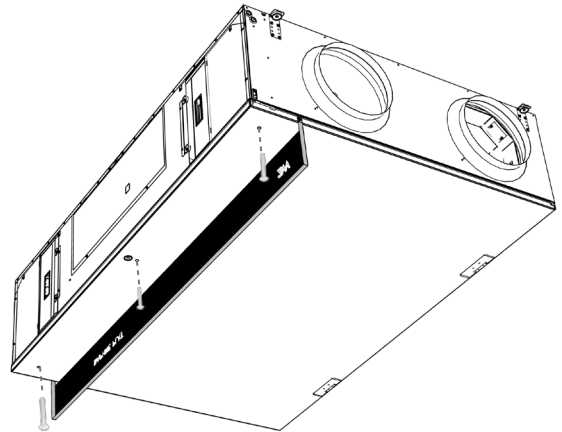

- replace filters

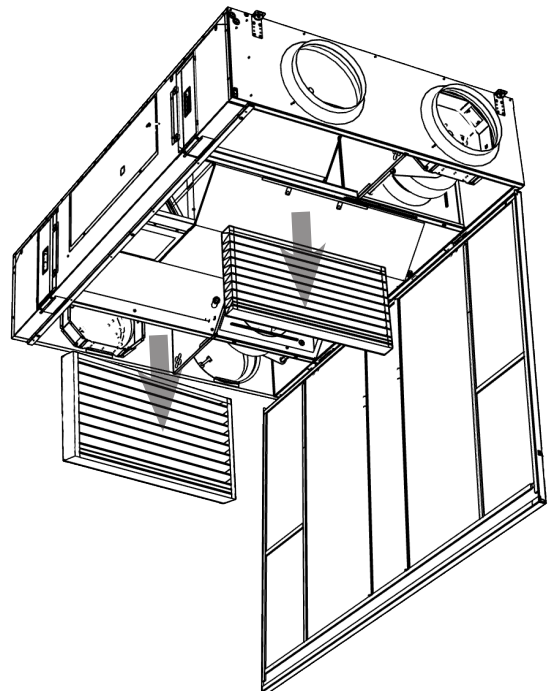

## 8.2 PERIODICAL CLEANING OF THE VENTILATION UNIT

We suggest checking and cleaning the unit every six months, however these intervals must be accommodated to specific operating conditions.

We suggest thorough cleaning of the unit once a year. If the unit is not in use for a long time, we suggest its activation every six months for about an hour.

### ATTENTION

**Service of internal components and cleaning of the unit must be carried out by professional service shop only! Operation of the unit without the filter is not allowed! Otherwise the heat exchanger can be damaged!!!**

Clean the ventilation unit, using a vacuum-cleaner, small brush, cloth and soapy water especially recuperator. Do not clean the unit with following: Sharp objects, aggressive chemicals, solvents, abrasive cleaning products, pressured water, pressured air or steam.

## 9. TROUBLESHOOTING

### ATTENTION!

*Before and during maintenance and repairs, the unit must be disconnected from the power supply, which must be locked, and the service switch in 0 position (off).*

*Do not perform repairs if you aren't sure or don't know the exact procedure; contact a specialised service!*

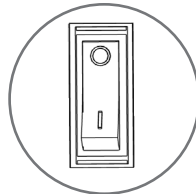

### TECHNICAL DATA

*Malfunctions are usually signalled with a message on the display. See table below.*

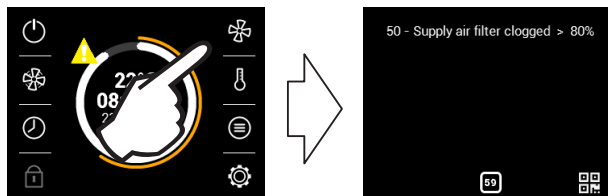

Description	Unit's behaviour	Likely problem	Solution
4 – Supply fan error	Unit is not working	Overheated fan or defect on thermal contact of inlet fan	Determine the cause of the overheating (defective bearing, short-circuit...) or replace the engine.
5 – Exhaust fan error	Unit is not working	Overheated fan or defect on thermal contact of inlet fan	Determine the cause of the overheating (defective bearing, short-circuit...) or replace the engine

## 9. TROUBLESHOOTING

Description	Unit's behaviour	Likely problem	Solution
12 – CO2 sensor failure	Unit is ventilating	Defective air quality sensor	Check that the CO2 sensor is connected correctly or check that it is operating correctly (output signal value)
16 – Inlet – External temperature sensor failure (T-EXT1)	Unit is not working	Room temperature sensor failure	Check that the sensor is correctly connected to the electronics or test it measuring its resistance (the resistance value at +20°C is around 10kΩ)
17 – Inlet – Failure of the temperature sensor behind the exchanger (T-EXT2)	Unit is not working	Room temperature sensor failure	Check that the sensor is correctly connected to the electronics or test it measuring its resistance (the resistance value at +20°C is around 10kΩ)
18 – Inlet – Temperature sensor failure in the supply canal (T-EXT3)	Unit is not working	Room temperature sensor failure	Check that the sensor is correctly connected to the electronics or test it measuring its resistance (the resistance value at +20°C is around 10kΩ)
20 - Exhaust – Temperature sensor failure in the exhaust canal (T-INT0)	Unit is not working	Room temperature sensor failure	Check that the sensor is correctly connected to the electronics or test it measuring its resistance (the resistance value at +20°C is around 10kΩ)
21 – Exhaust – Temperature sensor failure in the exhaust canal (T-INT1)	Unit is not working	Room temperature sensor failure	Check that the sensor is correctly connected to the electronics or test it measuring its resistance (the resistance value at +20°C is around 10kΩ)
25 – Room temperature sensor failure (T_Room)	Unit is ventilating	Room temperature sensor failure	Check that the sensor is correctly connected to the electronics or test it measuring its resistance (the resistance value at +20°C is around 10kΩ)
32 - Air quality sensor failure	Unit is ventilating	Defective air quality sensor	Check that the quality sensor is connected correctly or check that it is operating correctly (output signal value)
33 - Failure in the recirculation relative humidity sensor	Unit is ventilating	Defective relative humidity sensor	Check that the humidity sensor is connected correctly or check that it is operating correctly (output signal value)
34 - Failure in the sensor of external temperature from BMS	Unit is ventilating	Defective sensor in BMS or incorrectly received data	Check that the address and values of the sensor in the BMS system are correct. Check that the sensor in the BMS system is working.
73 - Pre-freecooling active	Unit is ventilating	Temperature evaluation for freecooling mode in progress	Preparation for freecooling mode in progress. It evaluates the temperature and the conditions necessary to activate this mode.
74 – Flow reduction, minimum temperature in the canal not reached	Unit operates in a restricted mode	The unit is trying to reach the set values of the channel's minimum	The temperature of the air flowing into the inlet branch of the building has not been reached. The performance of the unit is being automatically corrected to reach this minimum level. Automatic process
75 - Passive house protection	Unit is not working	The unit is operating in order to meet the Passive house specifications	The temperature of the air flowing into the inlet branch of the building is not within the Passive House specifications. Automatic process

## 9. TROUBLESHOOTING

### **ATTENTION!**

When the power supply is resumed after an outage, the unit returns to the status it was before the outage. The unit always remembers its operational status and settings. If you aren't able to find or remove the cause of the malfunction, or if the repairs require an intervention on the device, contact an authorised service.

**The service of internal components must be done only by a professional. Always disconnect the unit before servicing.**

### **Electric heating overheated:**

The safety thermostat disconnects if the heater overheats. After eliminating the cause of the overheat the safety thermostat located on the electric heater has to be reset manually.

The location of the safety thermostat is indicated with the marking: RESET located in each unit.

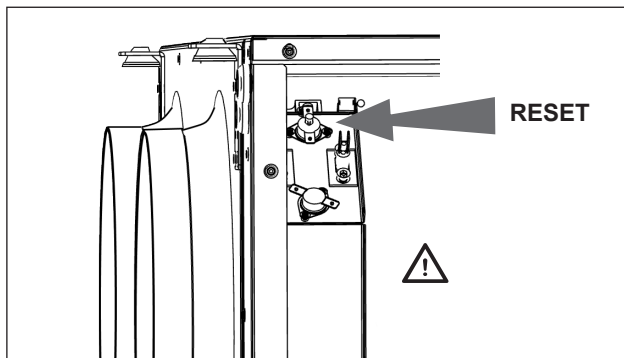

### **FUSE LOCATION**

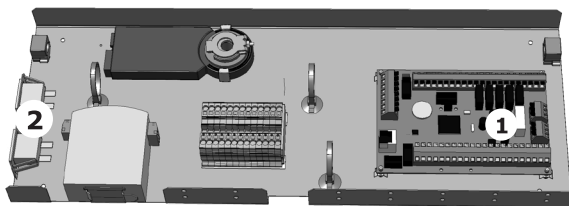

- ❶ Fuse location on the electronic board:  
T2L 5x20mm 250V
- ❷ Fuse motor and accessories:  
label next to the fuse or directly on the fuse.

### **READ CAREFULLY!**

*When the power supply is resumed after an outage, the unit returns to the status it was before the outage. The unit always remembers its operational status and settings.*

*If you aren't able to find or remove the cause of the malfunction, or if the repairs require an intervention on the device, contact an authorised service.*

## IF YOU CAN'T FIX A MALFUNCTION

Contact the supplier if you can't fix a malfunction.



### **READ CAREFULLY!**

- For quick troubleshooting, have the following information ready:
- type of product
- serial number operation time
- accessories used location of the unit
- connection conditions (incl. electrical)
- detailed description of the malfunction and the actions taken to fix it

## 10. DECOMMISSIONING THE PRODUCT – LIQUIDATION

Render the unit useless before its disposal. Older units also have materials that can be reused. Take them to a collection yard. It is recommended to have the unit disassembled in a specialised facility so that the recyclable materials may be reused. Take the unusable components to a legal disposal site. The materials must be disposed of in compliance with the applicable regulations.

## 11. CONCLUSIONS



Read and observe the instructions herein for a safe and proper use of the unit. Do not hesitate to contact our sales or technical support department in case of any query or request for explanation.

**The producer shall not be liable for damages caused as a result of improper installation and operation contrary to the manual and the common practice of installation and operation of ventilation devices and regulations systems.**

## CONTACT

### Address

2VV, s.r.o.,  
Nádražní 794,  
553 51 Pardubice – Rosice,  
Czech Republic

### Internet:

<http://www.2vv.cz/>

