



PARTNER
IN VENTILATION
2VV.CZ

EN

ESSENSSE NEO

BASIC



Installation and operation instructions

4-118-0247



P04-0224-0517-00



CONTROL THE DELIVERY

PLEASE NOTE

Check the product for damages immediately after delivery. In case of damage on the packaging, contact the carrier. Claims not filed in due time will be disregarded.

- Check that it corresponds to the type of product ordered. In case of discrepancy, do not unpack the product and contact the vendor.
- After unpacking, check that the product and all the other components are in good order. In case of doubt, contact the vendor.
- Do not install a damaged unit!
- If you will not unpack the product immediately after delivery, store it indoors, in a dry place with ambient temperatures between **+5 °C and +40 °C**.

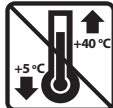

	All the packaging material is environmentally friendly and can be reused or recycled. Contribute actively to the protection of the environment and ensure the proper disposal or recycling of the packaging materials.	
--	--	--

PACKAGE CONTENTS

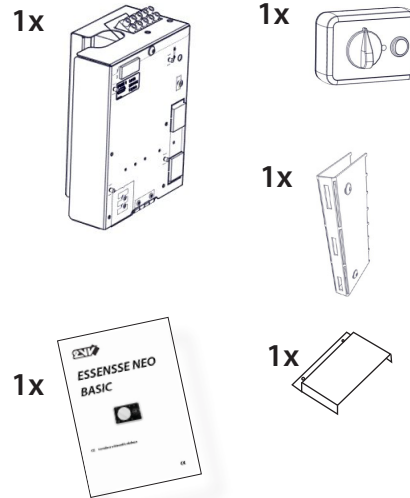

PLEASE NOTE

- If the unit was transported in temperatures lower than 0°C, after unpacking, leave it in operational conditions for at least two hours without activating in order to compensate the inner temperature.

1. INSTALLATION

4.2 CONNECTING THE CONTROL AND ACCESSORIES

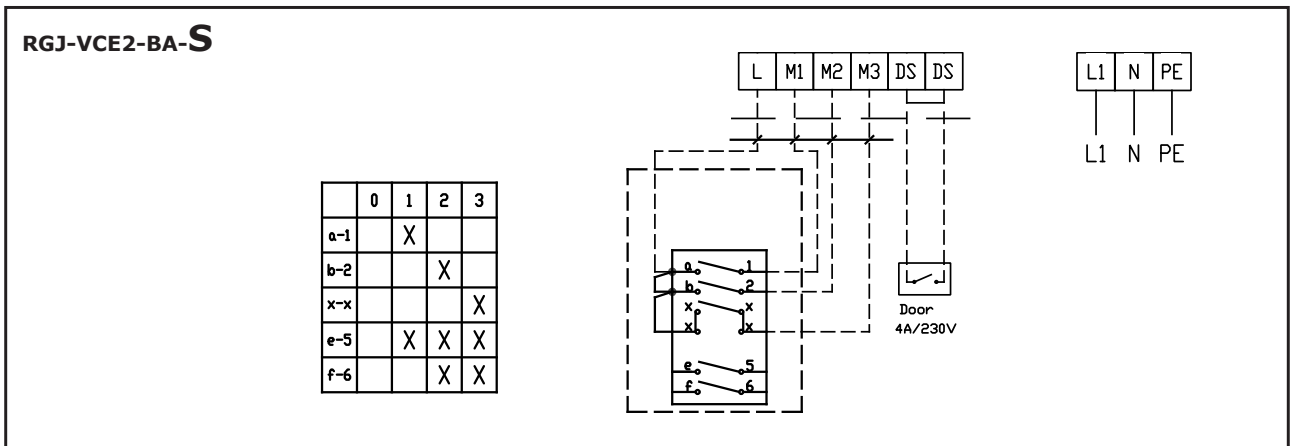
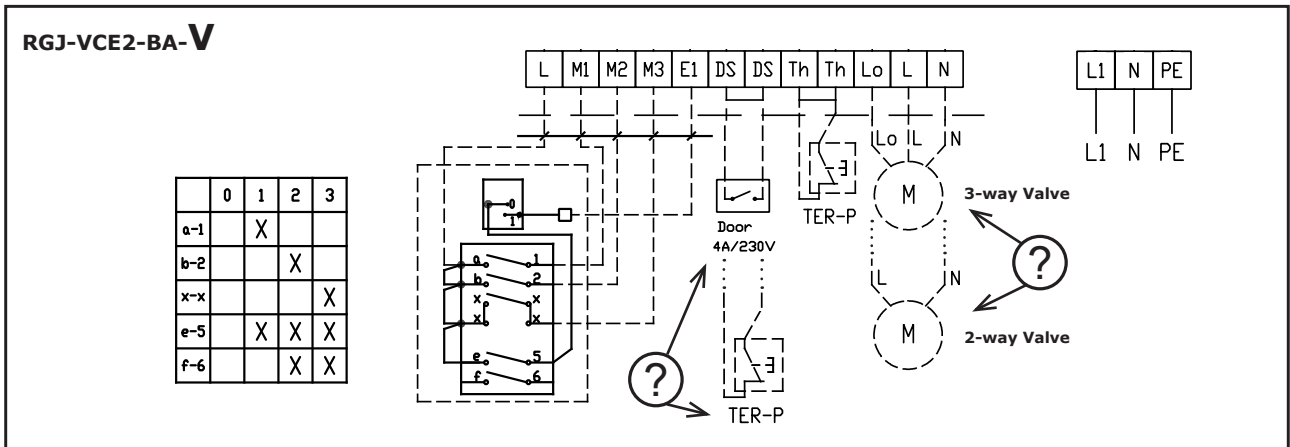
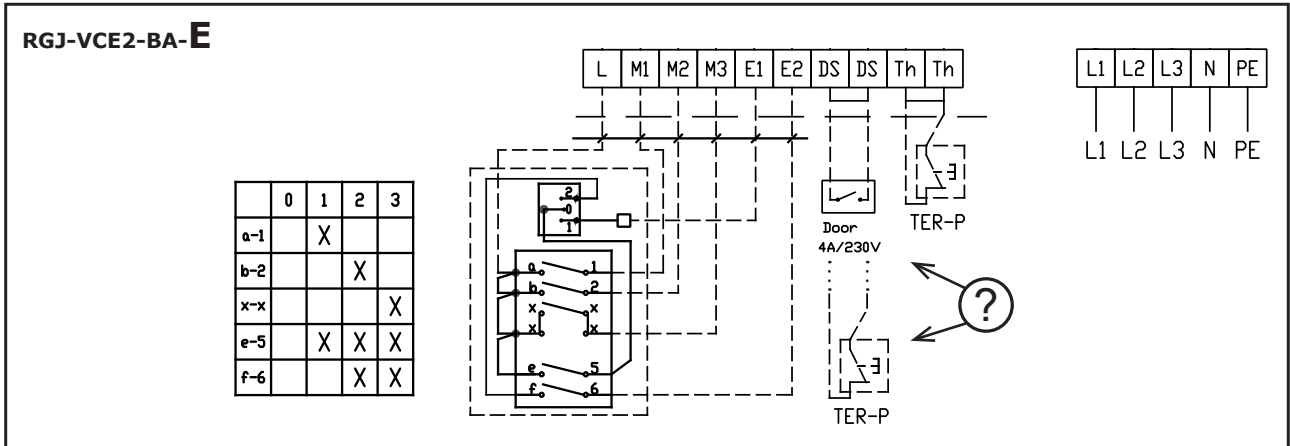

*A cable with a minimum cross-section of $6 \times 0.5 \text{ mm}^2$ is recommended for connecting the control.
 *The maximum recommended length of the cable is 100 m.

2. EXTERNAL ACCESSORIES

2.1 CONNECTING EXTERNAL ACCESSORIES



PLEASE NOTE

- The unit must be disconnected from the power supply to connect accessories.
- All external control components must be connected according to the wiring diagram.
- The connectors must be connected to the electrical board with adequate force and always perpendicular to the base.

2.1-1 DS door contact



TECHNICAL INFORMATION

- suitable for all BASIC regulation
- Isolated break contact with maximum voltage 230V, 6A
- IP67, can be connected as a break or switching contact

Connectors for control modules: DS / DS



CAUTION!

Not included with the product.

2.1-3 Thermostatic valve – TV1/1



TECHNICAL INFORMATION

- Thermostatic valve to regulate the water exchanger
- Suitable for all types of curtain with water exchanger
- Operates independent to the BASIC controls.



CAUTION!

Not included with the product.

2.1-4 Zone valve ZV-3 / RT-3-xx



TECHNICAL INFORMATION

- Zone valve to regulate the water exchanger
- Cable - Three-core cable with a cross-section of 1.5 mm², 230 V/ 50 Hz.



CAUTION!

Not included with the product.

2.1-5 Room thermostat - TER-P



Room thermostat -TER-P

- Room thermostat to regulate heating
- Cable - Two-core cable with a cross-section of 1,5 mm², 230 V/ 50 Hz.

Connectors for control modules: Th / Th

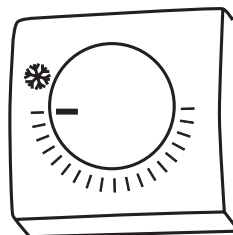
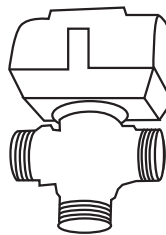

ATTENTION!

Not included with the product.

3. COMMISSIONING

PLEASE NOTE

Before starting up the unit, check the following:

- Did you leave inside tools or objects that could damage the unit?
- Is the supply of energy and heating water (if applicable) adequate?
- Is the unit well closed?
- Is the control module properly connected?
- Does the unit have adequate protection according to the applicable standards?

4. CONTROL

READ CAREFULLY!

Before the initial commissioning, check:

- that the device is well fastened to the support structure,
- that the device is properly closed
- that the power supply is properly connected, including the earthing and the external trigger protection,
- that all the electrical components are securely connected,
- that the installation complies with all the instructions herein,
- that no tool or any other object that may damage the unit remains within.

ATTENTION!

- Interventions or changes to the internal connections are forbidden and shall result in the loss of warranty.
- We recommend the use of accessories supplied by our company. Contact your supplier in case of doubts regarding the use of non-original accessories.

START-UP

After switching on the main power supply, activate the unit turning the switch to one of the three fan speeds.

The diagram shows a control panel with a large rotary switch on the left and a smaller rotary switch on the right. The large switch has three fan speed icons (one, two, and three blades) and a power icon. The smaller switch has three heating level icons (one, two, and three wavy lines) and a power icon. The panel is labeled with 'Curtain off', 'First fan speed', 'Second fan speed', 'Third fan speed', 'Heating off', 'First heating level', and 'Second heating level (only for electric heating)'.

	Curtain off			Heating off
	First fan speed			First heating level
	Second fan speed			Second heating level (only for electric heating)
	Third fan speed			

5. MALFUNCTIONS

5.1 MALFUNCTIONS

Disconnect the main power supply before any intervention to the unit. If you are not sure of the correct steps, do not attempt to perform any repairs and call a professional service!

Unit behaviour	Likely problem	Solution
Unit's not working	Power supply interrupted	Check that the power supply is not interrupted
	Cracked fuse	Check the fuse in side the control module
The heating switches off automatically	The heater overheats	The heater overheats due to insufficient air flow. Check that the ventilators are in good order and that the air supply is not disrupted.

 **ATTENTION!**

Switch off the main power supply before any intervention inside the unit. Let the unit cool!

6. MAINTENANCE

6.1 CLEANING

 **ATTENTION!**

- Do not use compressed air, chemicals, solvents or water to clean the unit.
- Use a soft brush or a vacuum cleaner to clean the suction cover and the inside of the unit.
- See the installation manual of the ESSENSSE NEO curtain

7. SERVICE

7.1 IF YOU ARE UNABLE TO REPAIR THE UNIT

If you were unable to solve a problem, contact the supplier or the representative of 2VV. Warranty and post-warranty service are provided by the supplier or an authorised service included in the list available at the supplier's.

Give the following information to the supplier or service:

- **type designation of the air curtain**
- **accessories in use**
- **place of installation**
- **serial number**
- **conditions of the installation (incl. electrical)**
- **period of operation**
- **detailed description of the malfunction**

7.2 – DECOMMISSIONING THE PRODUCT – LIQUIDATOIN

Before scrapping the product, make it unusable. Old products still have raw materials that can be reused. Take them to a collection centre for secondary raw materials. It is preferable to have the product liquidated by a specialist so that the recyclable materials may be reused. Take the unusable parts to an appropriate waste disposal site.



The liquidation of materials must observe the applicable waste management regulations.

8. WIRING DIAGRAM

RGJ-VCES2-BA-S-AC

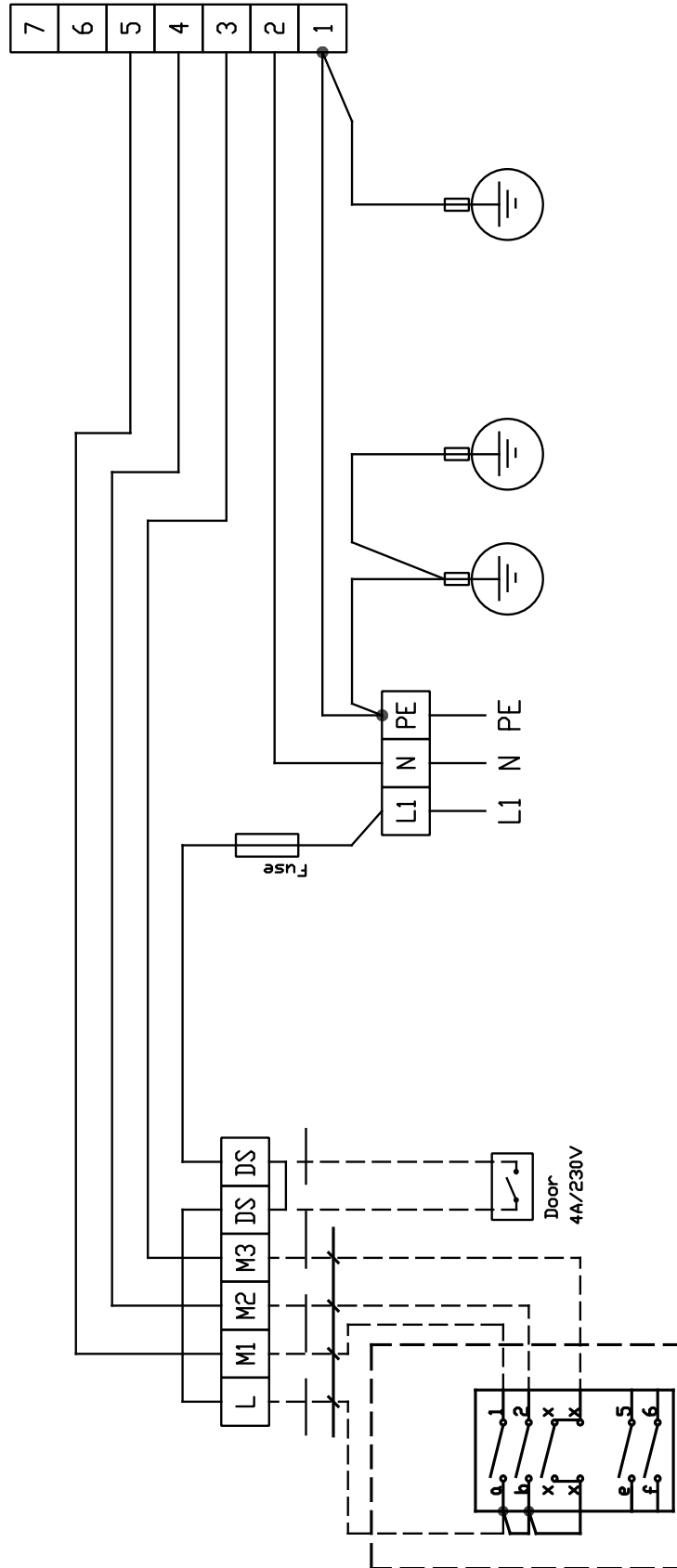

8 WIRING DIAGRAM

RGJ-VCES2-BA-E-AC

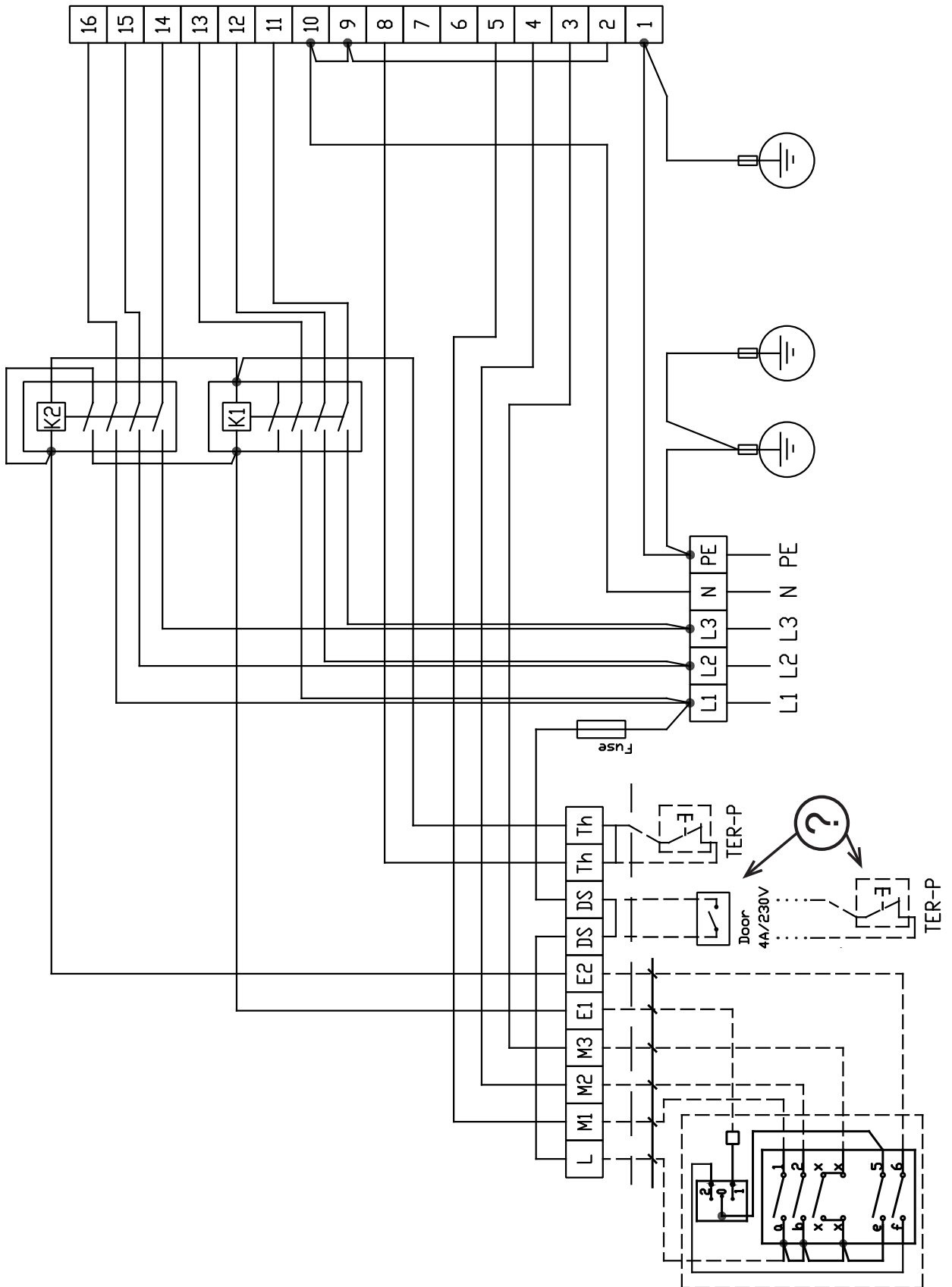

9. CONCLUSION

9. CONCLUSION

In case of any doubt or query, do not hesitate to contact our sales or technical support departments.

CONTACT

Address:

2VV, s.r.o.,
Fáblovka 568,
533 52 Pardubice,
Česká republika

Internet:

<http://www.2vv.cz/>

