



PARTNER
IN VENTILATION
2VV.CZ

IC3-CONTROL

EN

INSTALLATION
AND OPERATION MANUAL

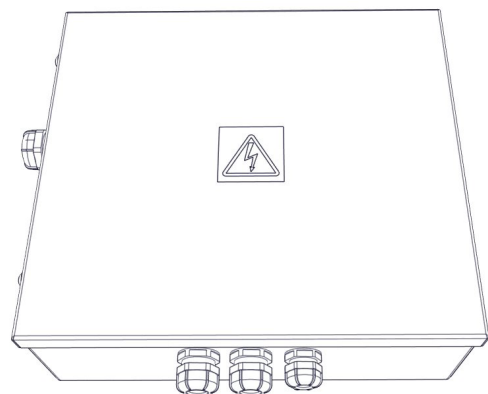
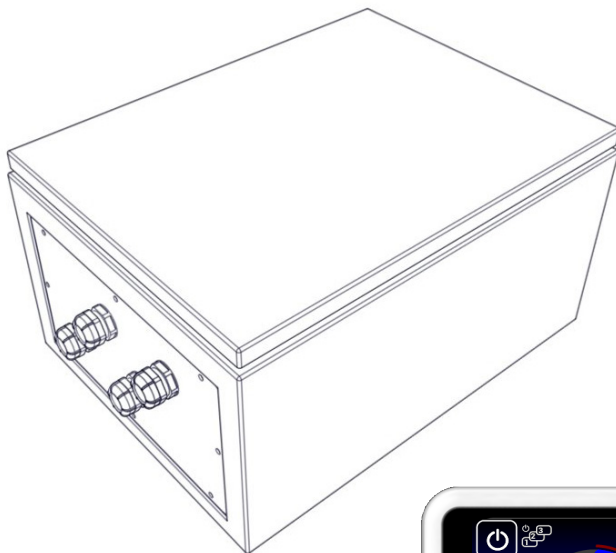





4-118-0335

ver.1 11-12-2019

1. BEFORE STARTING

The following symbols in the manual serve for better guidance. The following table describes the symbols and their meaning.

Symbol	Meaning
 ATTENTION!	Warning or Caution
 PLEASE NOTE!	Important instructions
 YOU WILL NEED	Practical tips and information
 TECHNICAL INFORMATION	Detailed technical information
	Reference to a different part of the manual



Before beginning with the installation, **read carefully the instructions** to safely and properly use the product.

This manual provides instructions on how to properly install the regulator. Before installing the regulator, read carefully the entire manual. The manufacturer reserves the right to make changes, including in the technical documentation, without prior notice. Keep the manual in a safe place for future reference. The manual is an integral part of the product.

Declaration of conformity

The product has been designed, produced and marketed in compliance with all the applicable provisions, and abides to the provisions of the European Parliament and Council, including the amendments under which it has been classified. It is safe under normal conditions and under the conditions laid down by the manual. The assessment was conducted pursuant to harmonized European standards included in the relevant EC Declaration of Conformity. The current and full version of the EC Declaration of Conformity can be found at www.2vv.cz

2. UNPACKING

2.1 CONTROL THE DELIVERY

PLEASE NOTE!

- Unpack the product upon delivery and control for damages. In case of damage, inform and file a report with the carrier.
- Any claims that have not been filed in due time, will be disregarded later.
- Check that you have received the model ordered. Should the delivered model differ from the one ordered, do not unpack the unit and notify the supplier immediately.
- After unpacking, check that the product and the accessories are in good order. Contact the supplier in case of any doubt.
- Do not attempt to commission a damaged product.
- If the product is not unpacked upon delivery, it must be stored in a dry room with a temperature range of **+5 °C to +40 °C**.
- This product must not be used by persons (incl. minors) with mental or physical disabilities, or insufficient experience or knowledge in the safe use thereof, unless they are supervised or instructed on how to use the product by a person responsible for their safety.
- Do not let children play with the unit.

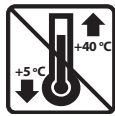

	<p>All the packing material is environmentally friendly and can be reused or recycled. Please, contribute actively to the protection of the environment and procure the regular disposal or recycling of packing materials.</p>	
--	---	--

PLEASE NOTE!

- If the product was shipped at below 0°C temperatures, let it rest for at least 2 hours, without turning it on, so that its inner temperature can match the surroundings.

2.2 UNPACKING THE UNIT

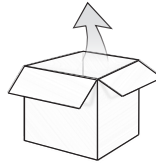

Regulator IC3-C-AC

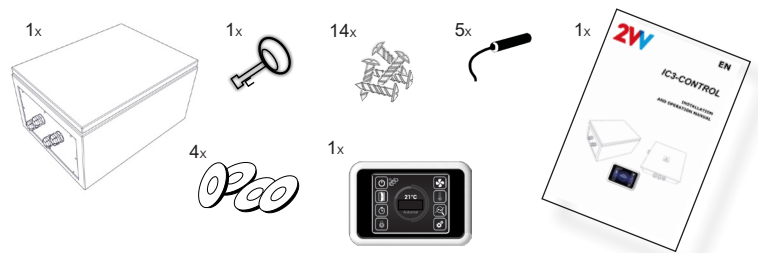

Regulator IC3-S-AC

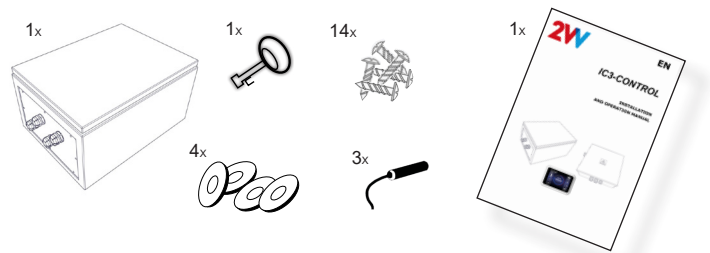

Regulator IC-C2-EC

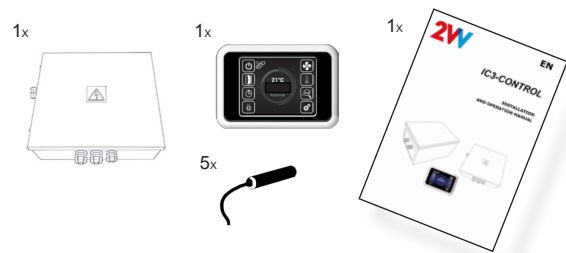

Regulator IC3-S-EC

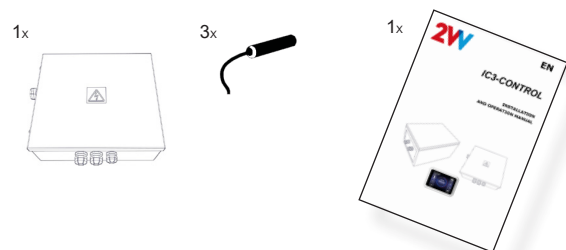

3. MAIN PARTS

Regulator IC3*-AC

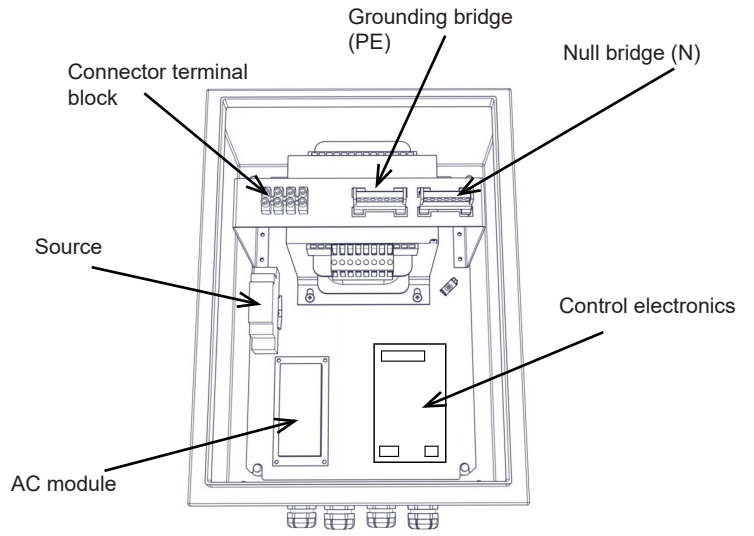
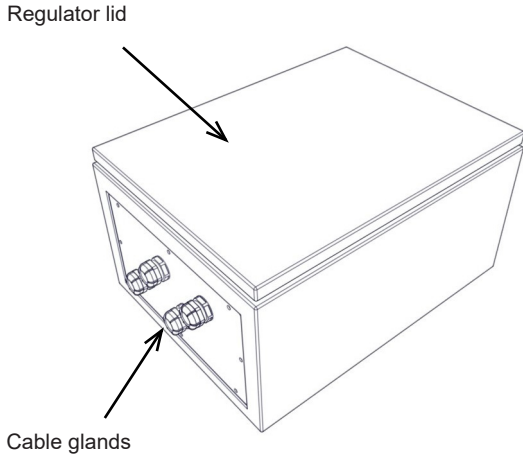

Regulator IC3*-EC

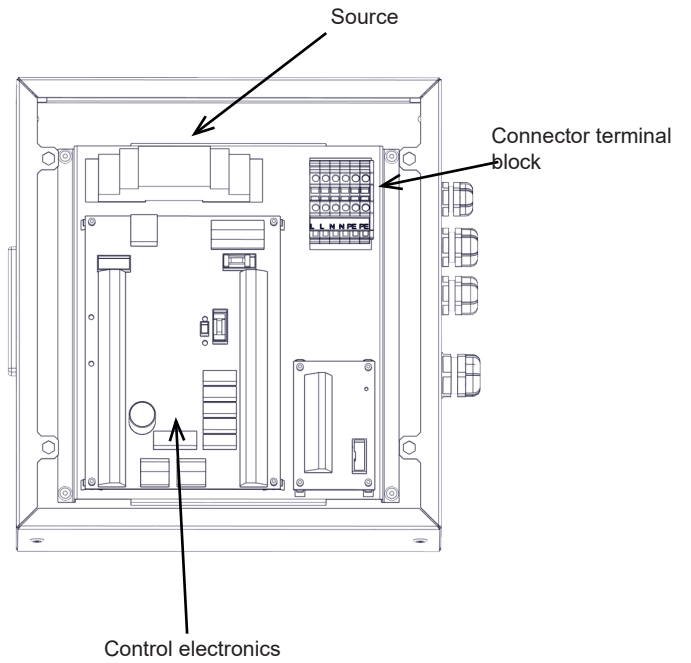
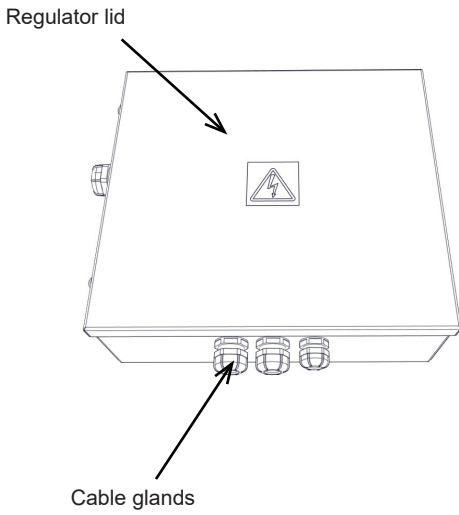

4. DIMENSIONS

Regulator IC3*-AC

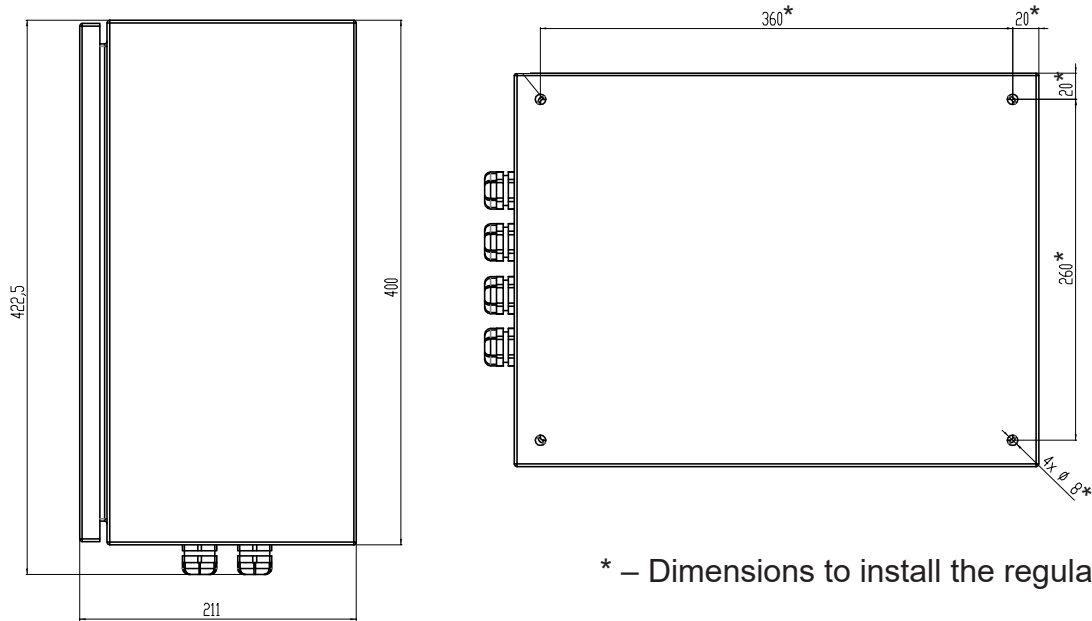

* – Dimensions to install the regulator on a wall

Regulator IC3*-EC

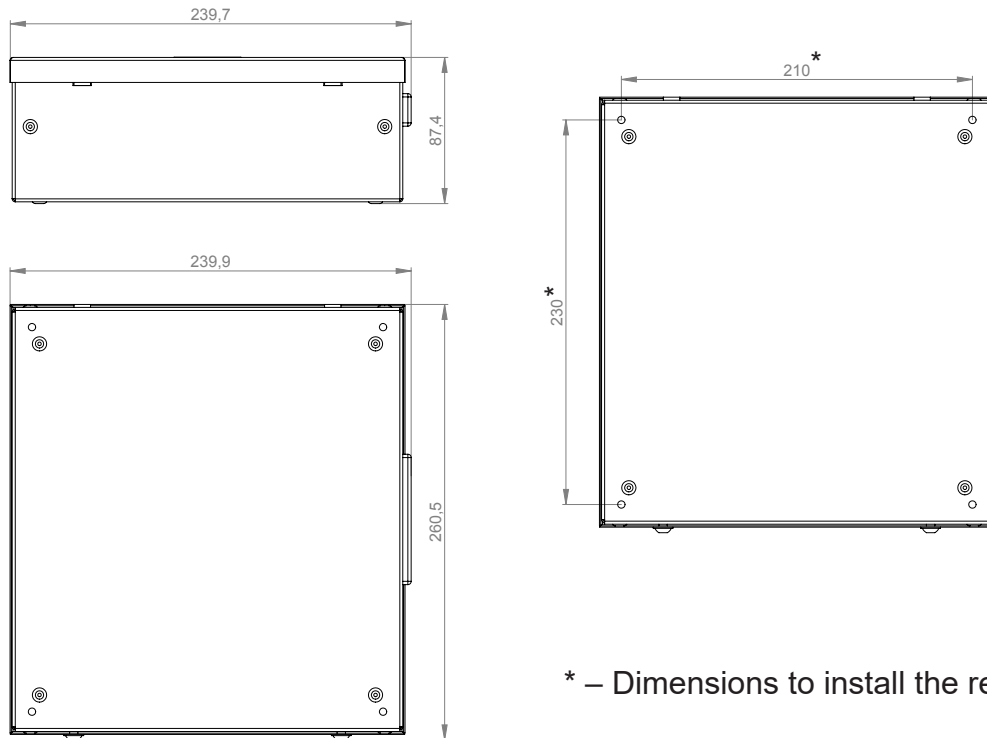

* – Dimensions to install the regulator on a wall

5. TECHNICAL PARAMETERS

Type	Supply [V/Hz]	Maximum current of AC fans [A]	Electrical protection [IP]	Weight [kg]	Maximum number of connected EC fans [pcs]
IC3-C-AC5-04	230 / 50~60	4	65	13,5	---
IC3-C-AC5-07	230 / 50~60	7	65	15	---
IC3-C-AC5-16	230 / 50~60	16	65	23	---
IC3-S-AC5-04	230 / 50~60	4	65	13,5	---
IC3-S-AC5-07	230 / 50~60	7	65	15	---
IC3-S-AC5-16	230 / 50~60	16	65	23	---
IC3-C-EC	115~230 / 50~60	---	40	3	10
IC3-S-EC	115~230 / 50~60	---	40	3	5

6. INSTALLATION

6.1 CHOOSING THE PLACE



The installation and main connection may be done only by a trained person with the appropriate qualifications, who has adequate tools and means. During the installation, observe all the instructions and recommendations in this manual.



TECHNICAL INFORMATION

The regulator must be operated in a place with the appropriate IP protection.

6.2 INSTALLATION

The regulator is installed on a wall, in a vertical position

It must be installed to allow air flow around it and to prevent overheating.

Observe the minimum recommended distances.

The regulator must be installed allowing adequate access in case of maintenance, service or disassembly.

The regulator is fixed to the wall with screws and wall plugs or with bolts.

There must be no flammable materials at a distance shorter than 100 mm from the regulator.

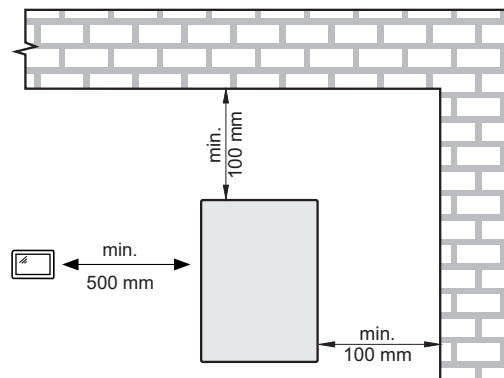

6. INSTALLATION

TECHNICAL INFORMATION

To install the AC regulator on a wall, we recommend to separate the inner part (electronics + transformer) from the box for easier handling.

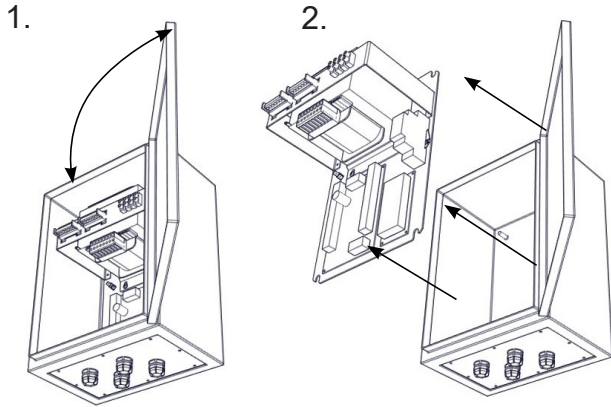

! The regulator must be installed as shown in the figures, with the cable glands downwards.

- Use adequate wall plugs and screws to fix the regulator.
- To keep the IP protection, use screws and the supplied washers



- Drill
- 4 screws
- 4 wall plugs
- 4 sealing washers (included)

6.3.ELECTRIC INSTALLATION AND WIRING

! ATTENTION!

- The regulator must be disconnected from the main supply before any intervention.
 - The installation might be done only by a professional with qualifications in electricity.
 - The manual must be observed, together with the laws and regulations applicable in the country.
 - The unit must be connected to the main power source with an isolated cable with a heat resistance in compliance with the diameter and the applicable laws and regulations of the country.
 - All the phases of the power supply must be connected through circuit breakers of appropriate current and type.
-
- The distance between open contacts must be greater than 3 mm.
 - The rated values of the electrical parameters of the unit are found on the nameplate.
 - The main supply, the switching components and accessories must be connected according the wiring diagram.
 - The connected fans must not exceed the rated current of the unit.
 - Alterations of the internal wiring of the unit are not permitted and will result in the loss of warranty.
 - In case of fire, use powder or CO2 extinguishers.
 - The regulator must be connected in a way that it can be disconnected from the power supply with one piece.

Recommended breakers:

Table of minimum sizes of breakers according to the model of the regulator

The adequacy of the circuit breakers will depend on the conditions specific to the place of installation. The following table is for reference only.

AC-C	
IC3-C-AC5-04	6A
IC3-C-AC5-07	10A
IC3-C-AC5-16	20A

AC-S	
IC3-S-AC5-04	6A
IC3-S-AC5-07	10A
IC3-S-AC5-16	20A

EC	
IC3-C-EC	2A
IC3-S-EC	2A

Connection of the control

* Recommended UTP CAT5 data cable (twisted pair)

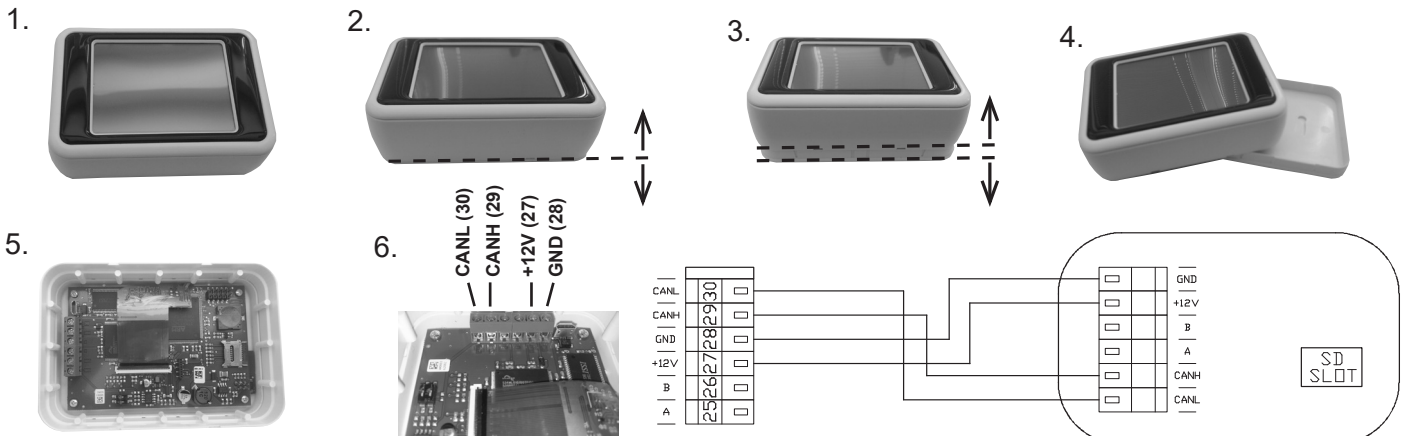

6. INSTALLATION

IC3-C-AC

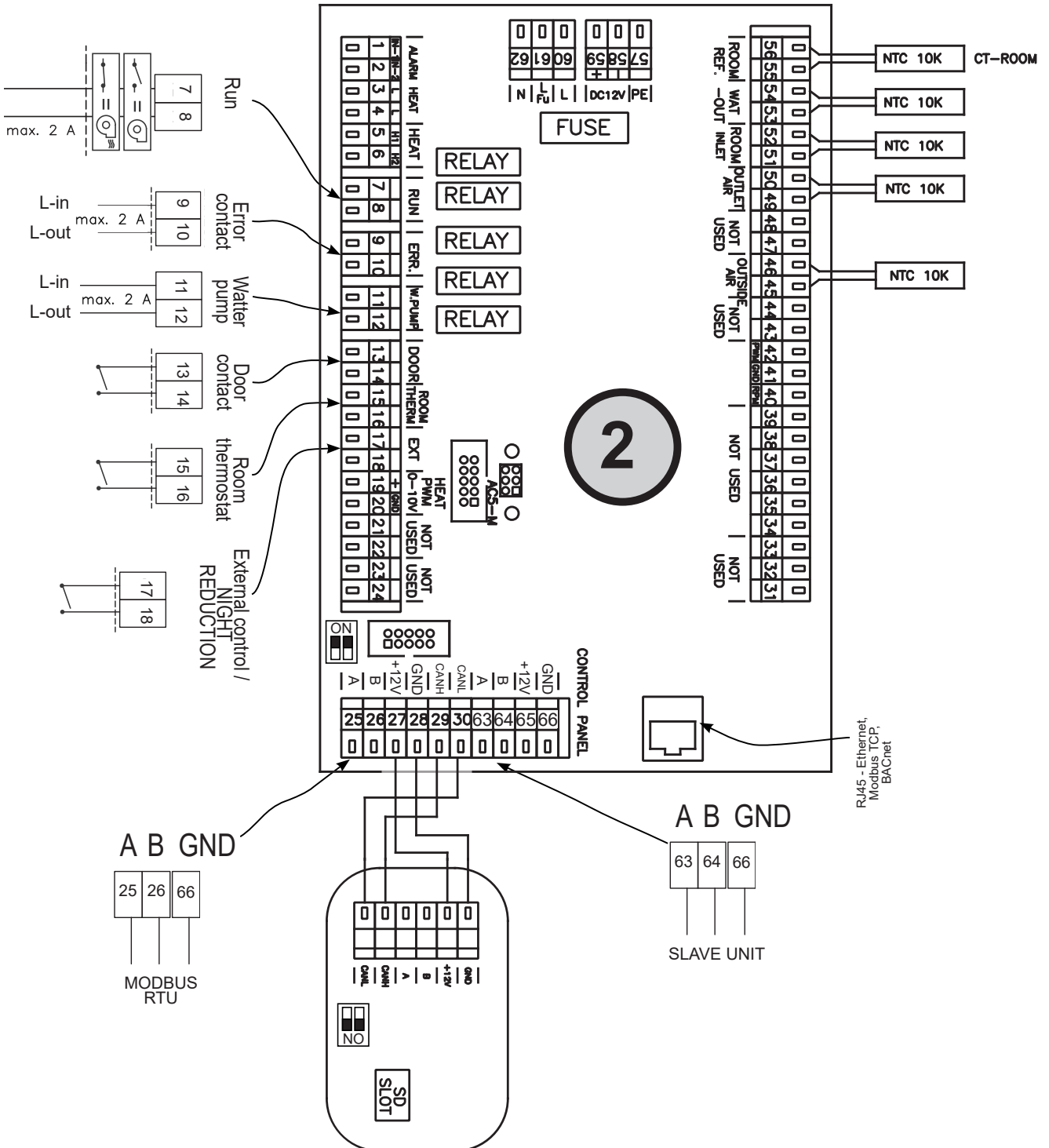
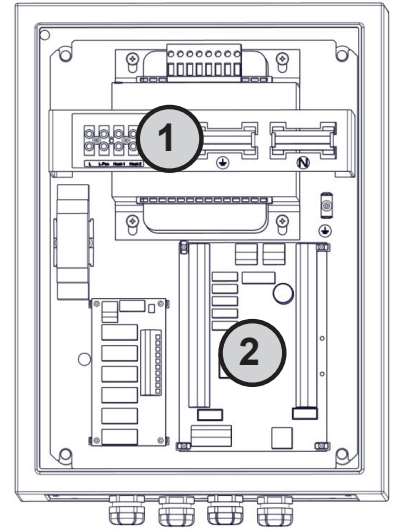
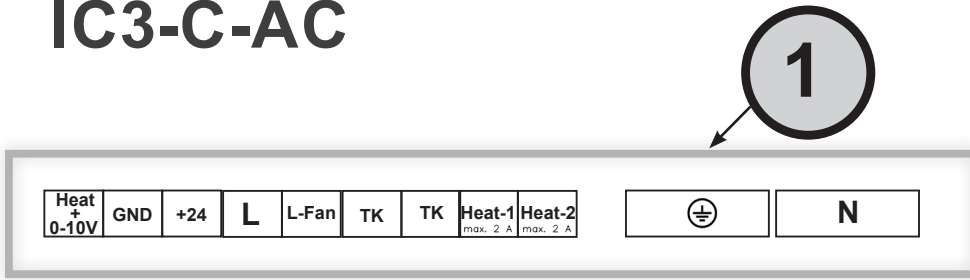

IC3-S-AC

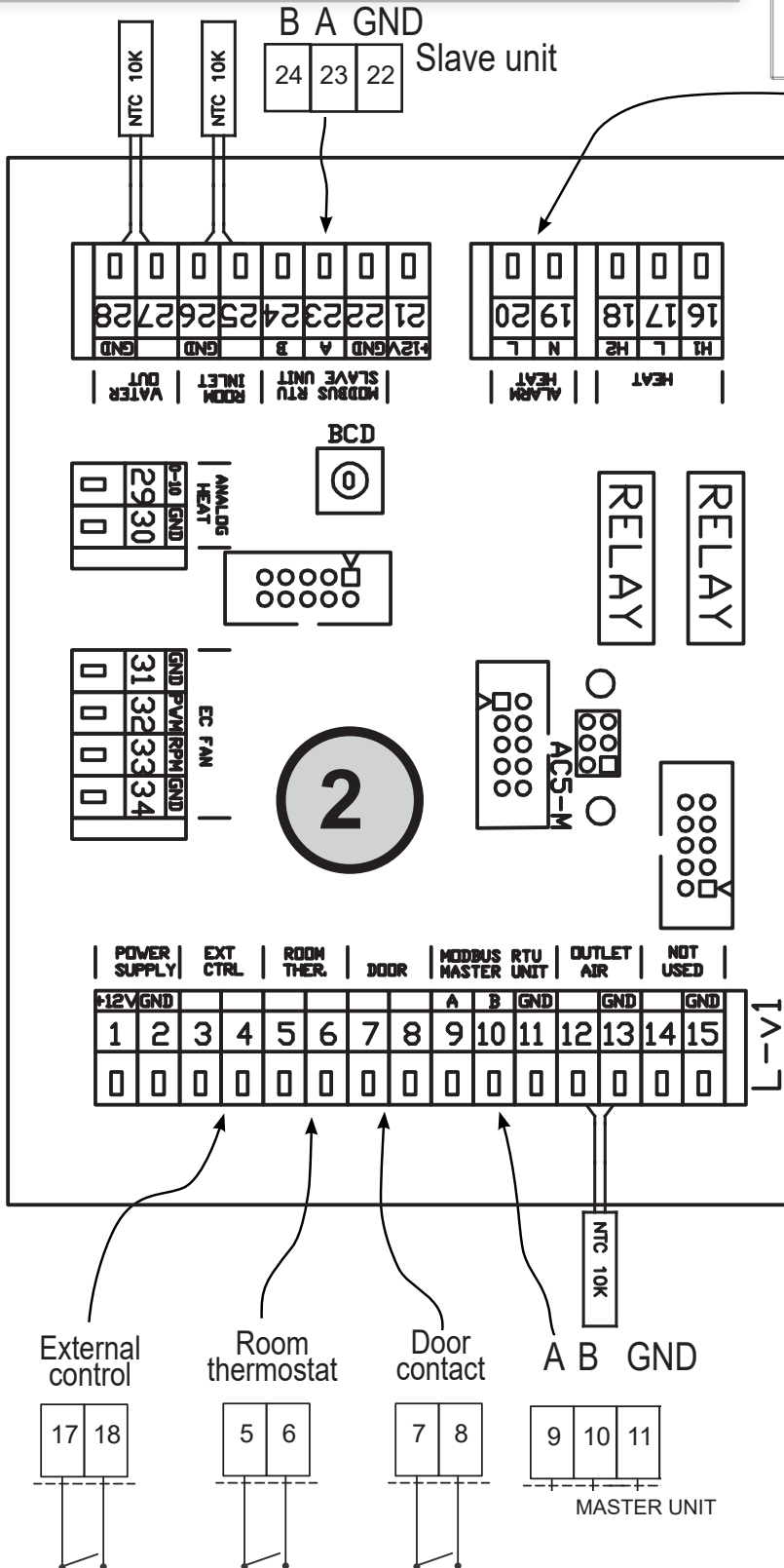
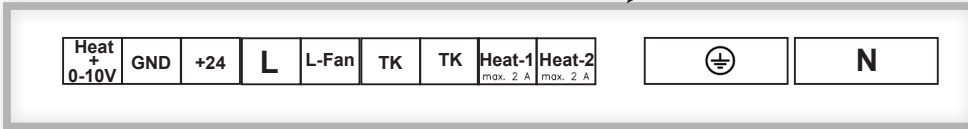
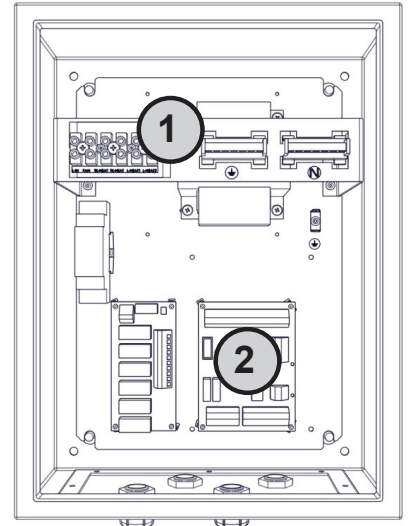

Recommended Alarm Heater wiring

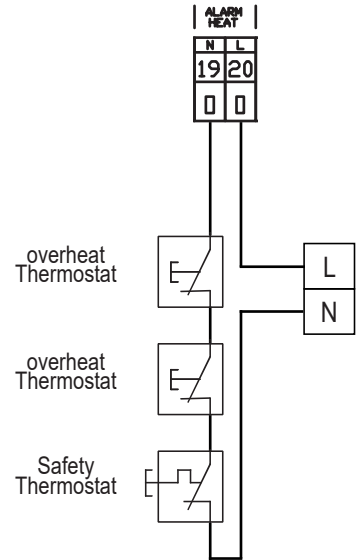

IC3-C-EC

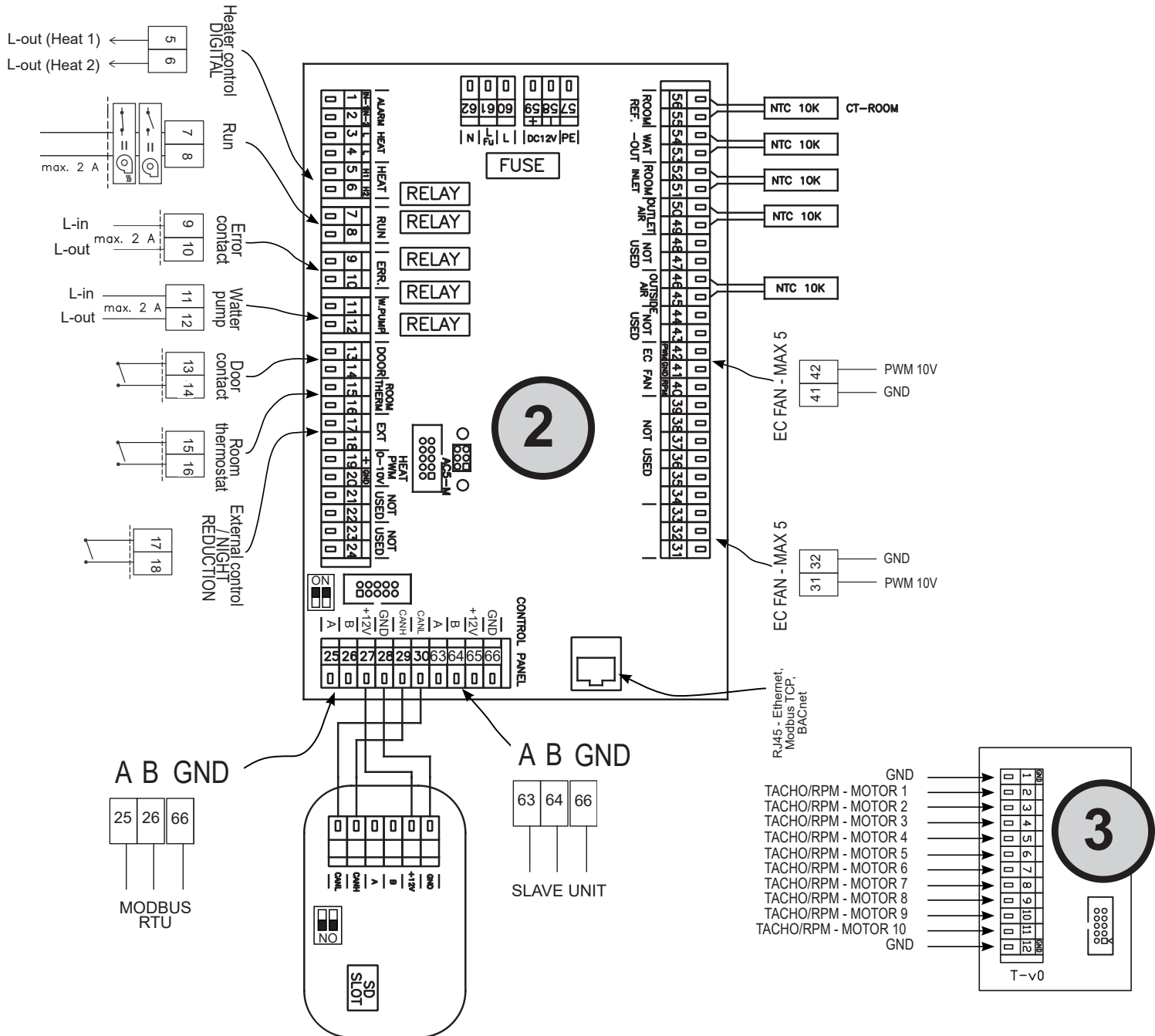
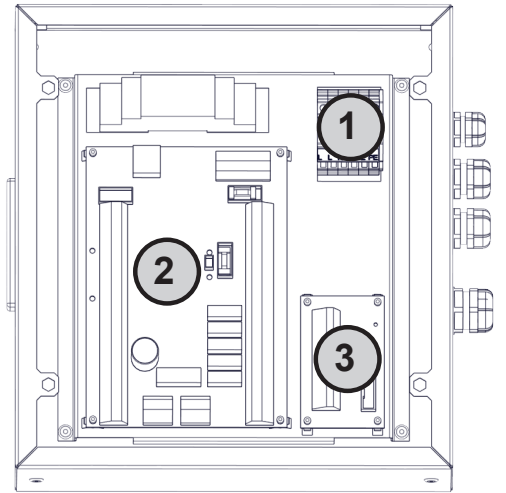
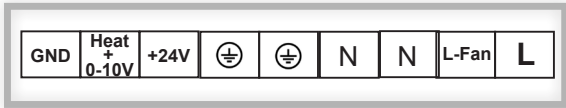

IC3-S-EC

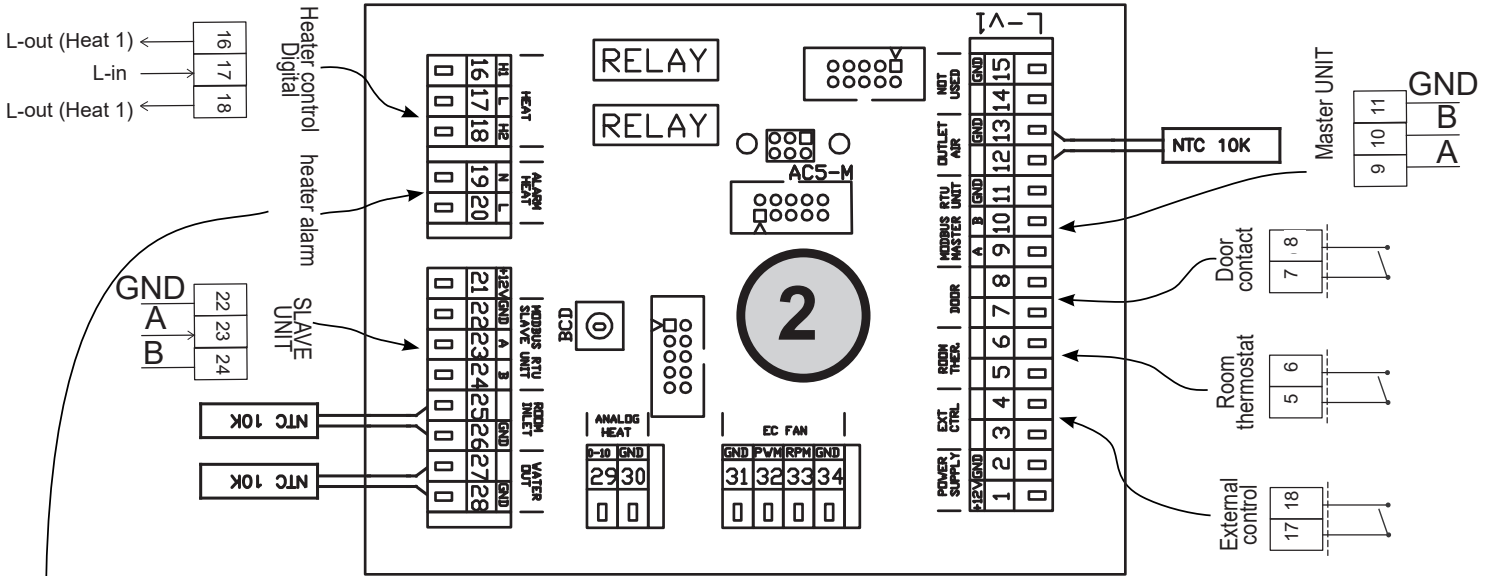
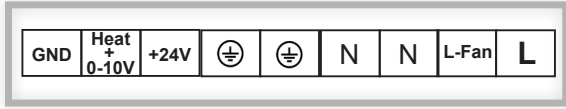
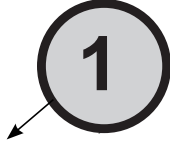
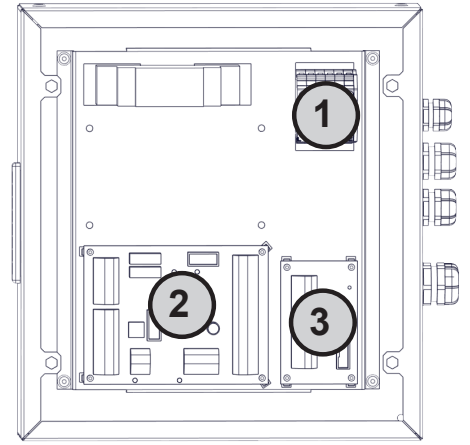

Recommended Alarm Heater wiring

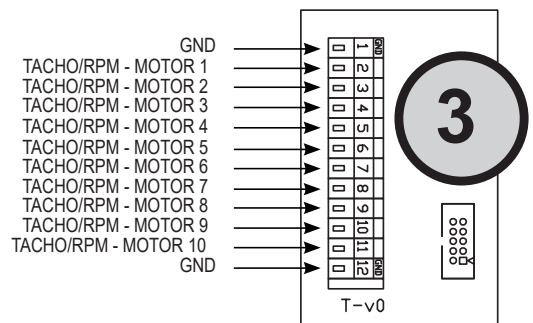
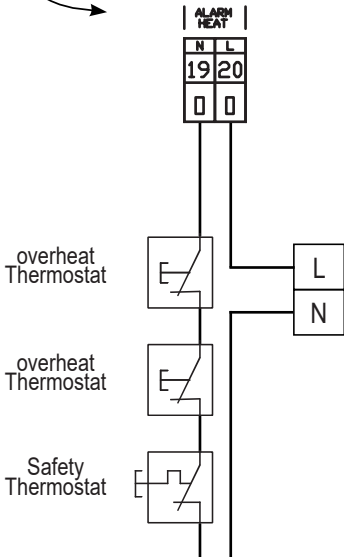

CHAINING

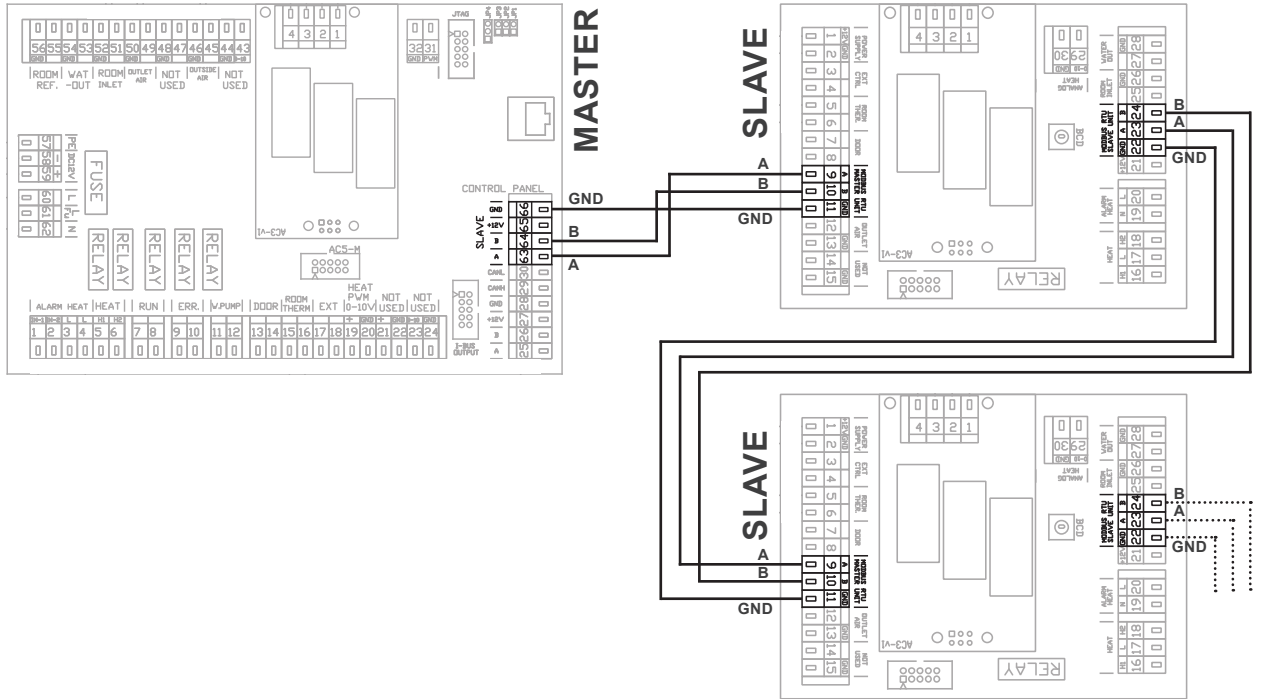
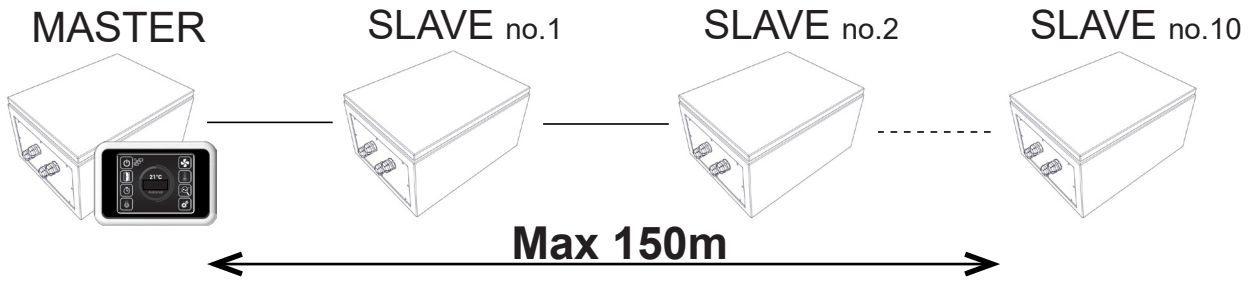

The total bus length of all chained air curtains must not exceed 150m !!!

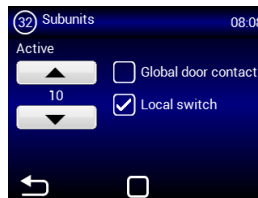
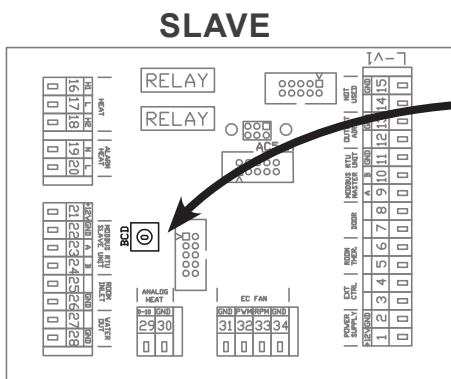

SLA-VE	BCD	SLA-VE	BCD
NO.1	1	NO. 6	6
NO.2	2	NO. 7	7
NO. 3	3	NO. 8	8
NO. 4	4	NO. 9	9
NO. 5	5	NO. 10	A

7. CONTROL

READ CAREFULLY!

Before the initial commissioning, check:

- that the device is well fastened to the support structure,
- that the device is properly closed
- that the power supply is properly connected, including the earthing and the external trigger protection,
- that all the electrical components are securely connected,
- that the installation complies with all the instructions herein,
- that no tool or any other object that may damage the unit remains within.

ATTENTION!

- Interventions or changes to the internal connections are forbidden and shall result in the loss of warranty.
- We recommend the use of accessories supplied by our company. Contact your supplier in case of doubts regarding the use of non-original accessories.

START-UP

After connecting power supply, the display lights up and the data is loaded. The device is ready to be activated once the service data has fully loaded.

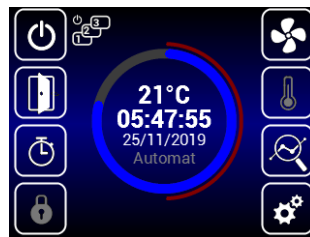

The remote control has a touch screen. The device is controlled tapping the symbols on the screen

Description of main screen

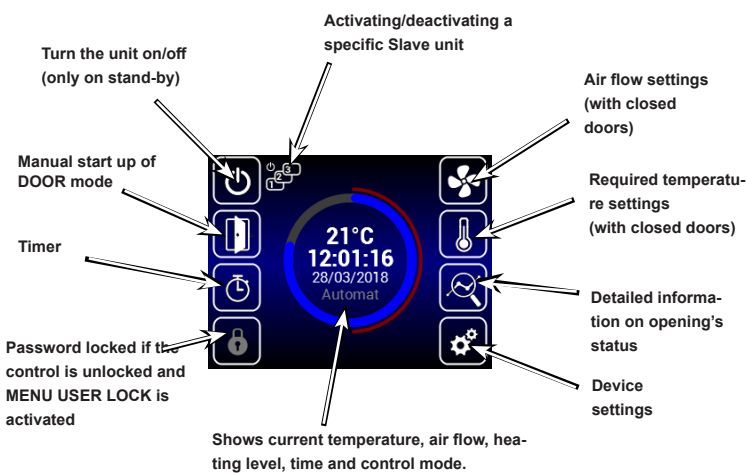

The menus are described below

- page 15
- page 16
- page 18

Warning icons

They inform about errors. Clicking on them opens a screen with the error report.

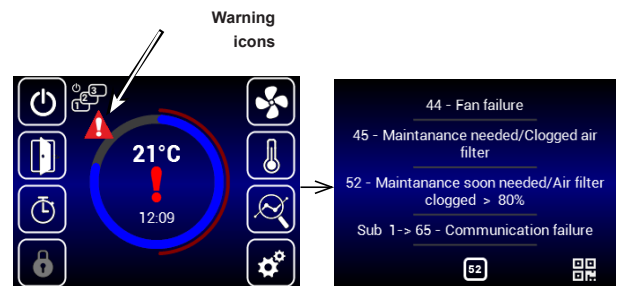

Information icons

They only inform about status, not errors.

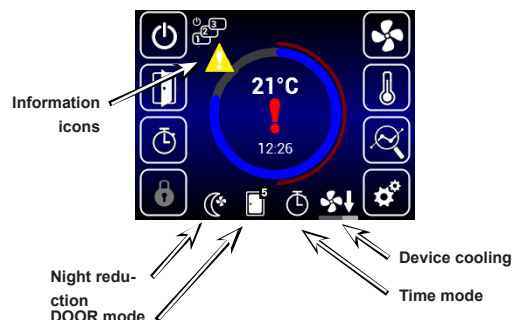

7. CONTROL



Current status

This screen shows the detailed status of the opening and the sensor values:

- Current air-flow settings (step or %), information icons
- Air temperature at intake*, exhaust*, room temperature* and outside temperature* (* – if the relevant sensors are installed and enabled)
- Heater output settings (if included)

Labels on the screen include: Outside temperature (16°C), Inlet temperature (20°C), Room temperature (22°C), Heat power (50%), Fan speed (80%), Return water temperature (21°C), SP= Temperature setpoint (45°C), and a 'Sun' icon indicating heating is blocked (summer mode). A green color indicates an active sensor.

The information on any connected SLAVE units will be shown here. It can be accessed moving the screen upwards.

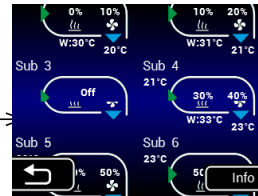

The settings can be found below, under "SUBUNITS"



Settings MENU

Options include: Display backlight, Language, Date and time, Air flow settings (with closed doors), App, Required temperature settings (with closed doors), Back to previous screen, and Parameters.



Required temperature settings with closed doors

Labels include: Actual temperature at selected sensor in menu 09 (21°C), Required output (Manual mode = %, Automatic mode = °C), and arrows for reducing or increasing the required temperature.

If the heating is blocked in summer mode (MENU - SUMMER HEATING), the screen will show a "Sun" icon and will not allow to select the output.



Air flow settings with closed doors

Labels include: Display required air flow (20% steps), Display the current air flow status (80%), and arrows for reducing or increasing opening's air flow (with closed doors).



Date and time settings

Labels include: Current date and time (09 03 28 02 2018) and a 'Back to main screen' button.

7. CONTROL



Timer

Unless otherwise set, the unit goes on stand-by mode after the timer expires.

Activate/deactivate timer

Weekly mode

Annual mode

Confirm + return

Back to main screen



Language

There are 5 languages available

Select language

Confirm + return

Back to main screen

Confirmation of selection

Weekly mode

Tap on a day to set different time modes

Button to copy the day plan to another day

Copy + return

Copy to

Annual mode

START / STOP interval

Tap to add a new time mode

Only MANUAL

Required ventilation rate in manual mode

Required heating rate in manual mode

CANCEL



Lightning settings

Display backlight when on

Lightning level on stand-by

Confirm + return

Back to main screen

7. CONTROL



AirGENIO App



QR code for downloading the AirGENIO application for smart devices

Pairing mobile device with unit using QR code.

Pairing smart device:

The IP address and PIN of the unit can be entered manually or by using a QR code for quick pairing of the unit.

1. Pairing using QR code:

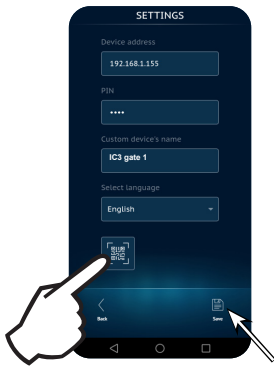
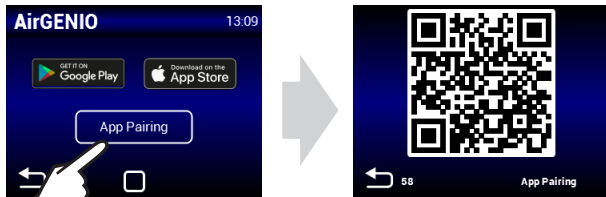

After scanning QR code from the controller press "Save" for saving the unit to the app.



2. Manual pairing:

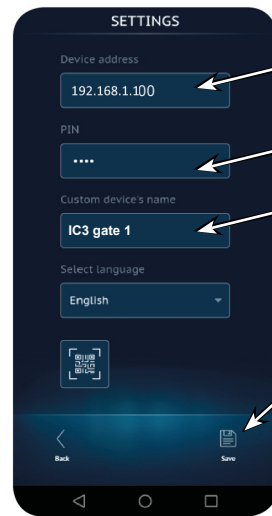
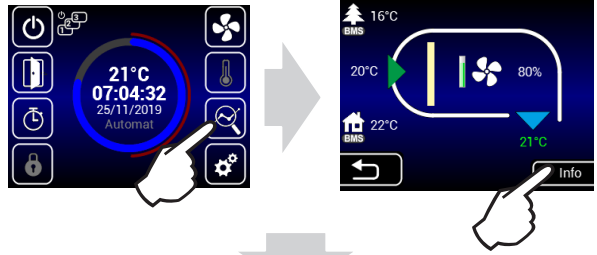

Enter the IP address from controller

Enter the PIN from the controller

Device's name

After entering all the information from the controller press "Save" for saving the unit to the app.

7. CONTROL



Servicing menu

Use code 1616 to access the servicing MENU

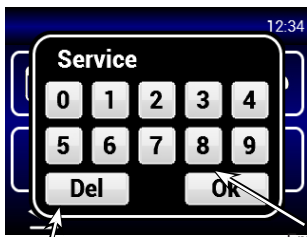

1616

Delete/go back

Enter menu

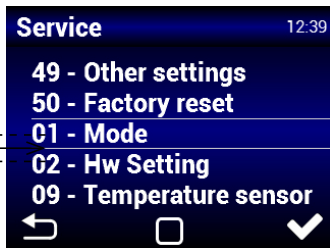

Select the MENU after scrolling to the middle of the page and clicking to enter

Enter selected menu

MENU - MODE

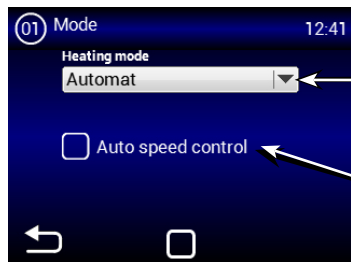

Select MANUAL/AUTOMATIC heating mode

Activation/deactivation of automatic motor rotation control by temperature

If you set the function AUTO or MANUAL, certain items can be enabled/disabled in the servicing MENU

MENU - HW SETTING

In this MENU you can set the detailed behaviour of the individual regulator inputs and outputs

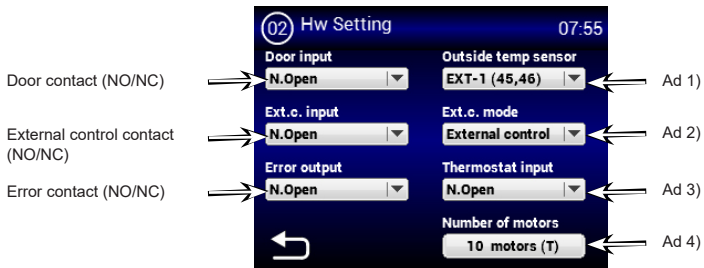

Ad 1) - Activation/settings of outer temperature sensor. Available selections:

- None - sensor not connected/inactive
- EXT-1 (45,46) - sensor connected (must be on connectors 45 and 46)
- BMS - temperature sensor active and used from master system

Ad 2) - Setting the behaviour of external contact input. Available selections:

- None - inactive
- External control - External activation/deactivation of device
- Night reduction - Activation/deactivation of night dimming (settings described later in this guide)

Ad 3) - Thermostat (NO/NC)

Ad 4) - Number of connected EC motors on regulator: 0-10pcs
Don't forget to connect the speed outputs of the motors to the appropriate connectors on the panel of the regulator, per the following schematic:

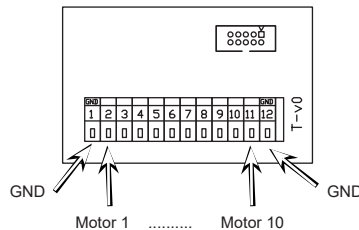

If the situation should occur that it is not required to check the speed output of the motors, this function can be blocked:

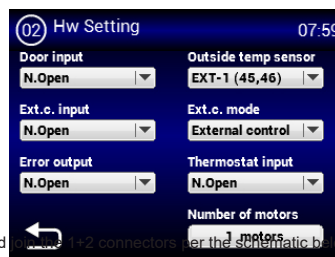

In the quantity of the "number of motors" menu, select the value "1"

And connect the 1+2 connectors per the schematic below.

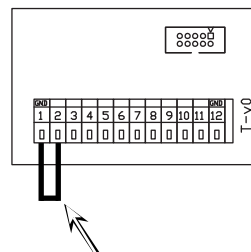

7. CONTROL

MENU - FILTER TIMER

This MENU allows you to set the time (by motor hours) after which an alert to replace filters is displayed, if applicable, to reset the timer after replacing filters

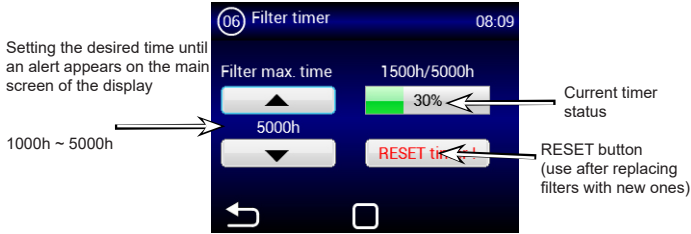

Sample display of status of fouled filter on main screen

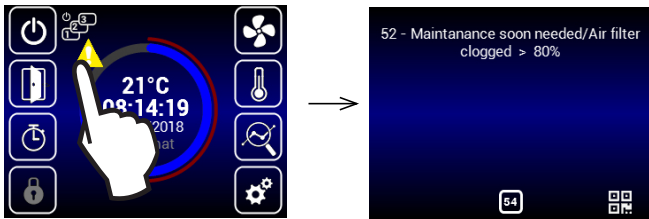

MENU - EXCHANGERS

The type of heat exchanger the controlled device contains may be set in this MENU.

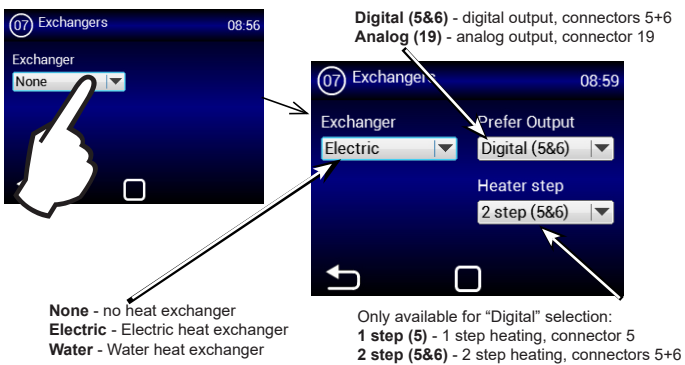

MENU - TEMPERATURE SENSOR

Available in Automatic Mode only.

In this menu the temperature sensor that will be used for primary temperature control can be selected
For air curtains with electric heaters, do not use the exhaust sensor to regulate the temperature. This setting can significantly reduce the service life of contactors!

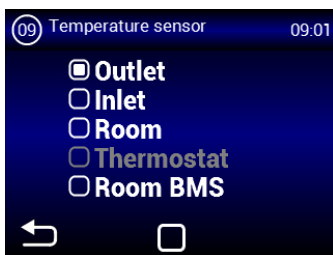

Available selections:

- Outlet - Temperature sensor for exhaust from device (behind heat exchanger)
- Inlet - Temperature sensor for part of device tray (before heat exchanger)
- Room - Spatial temperature sensor (for example, in the room)
- Thermostat - Spatial thermostat (functions ON/OFF)
- Room BMS - Spatial temperature sensor from master system

MENU - OUTLET TEMP LIMITS

This MENU enables limits to be set for exhaust from the device

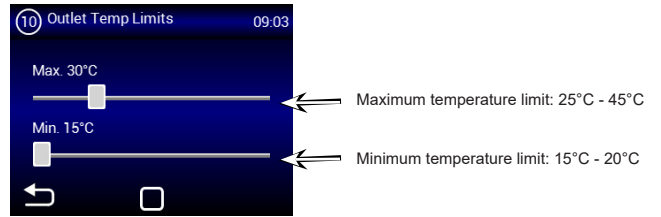

If the MENU TEMPERATURE SENSOR contains the set value "OUTLET", the values cannot be set in this MENU, because the limits are already defined by the sensor. This screen is displayed:

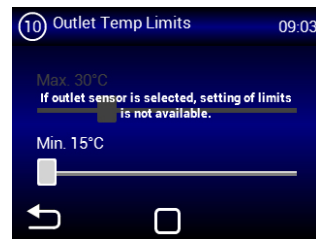

MENU - MODBUS RTU

This MENU allows for the setting of communications parameters for the Modbus RTU



Incorrect settings can lead to inability to communicate with the regulator

MENU - NETWORK

This MENU allows for the setting of communications parameters for network interfaces

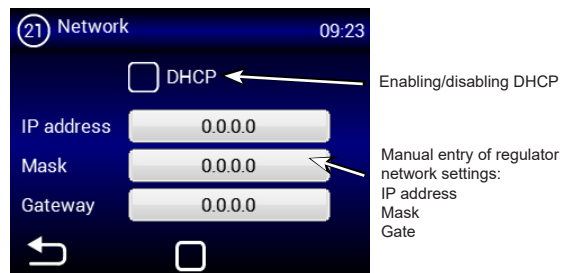

Incorrect settings can lead to inability to communicate with the regulator

7. CONTROL

MENU - USER LOCK

Use this menu to set the limits to control the regulator with a multi-level panel

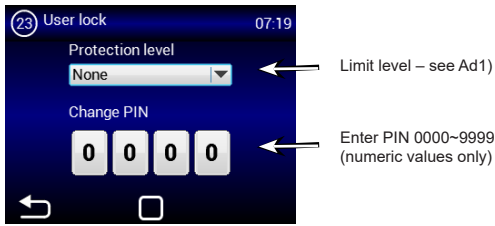

Limit level – see Ad1)

Enter PIN 0000-9999 (numeric values only)

Options:

None – Limit inactive

On/Off – Only On/Off and access to the information menu are enabled in the main screen

On/Off, Temp, Flow – On/Off, the information menu, and temperature and air flow settings can be accessed without password.

Full – Only the information menu can be accessed without password

User mode – Special user mode, see image below



MENU - SUMMER HEATING

Use this menu to set heating limits in summer months

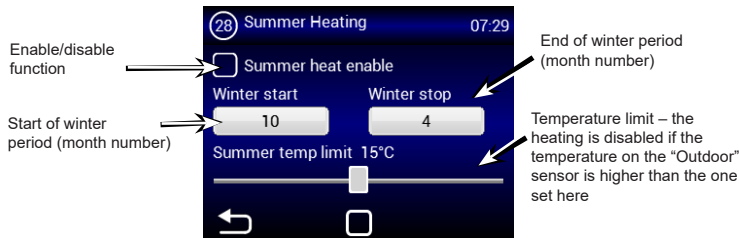

Enable/disable function

Start of winter period (month number)

End of winter period (month number)

Temperature limit – the heating is disabled if the temperature on the "Outdoor" sensor is higher than the one set here

If the outside temperature sensor is not set, the "summer heating" mode will operate only according to the selected time and the temperature will not be taken into account

MENU - Night Reduction

This MENU allows for setting reduced temperatures during night hours with closed doors.



Setting start time for reduced temperature

Setting time for ending reduced temperature.

Setting reduced temperature range -1~-5°C

Activating function

In this menu, the reduction of temperature may be set only by five degrees at the set time compared to the set (required) temperature.

MENU - DOOR CONTACT

This MENU allows for setting the behaviour of the regulator according to doors contact

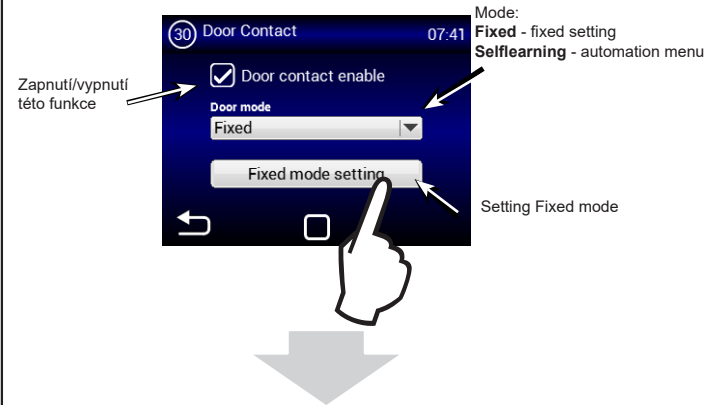

Zapnutí/vypnutí této funkce

Mode: Fixed - fixed setting Selflearning - automation menu

Setting Fixed mode

Time interval

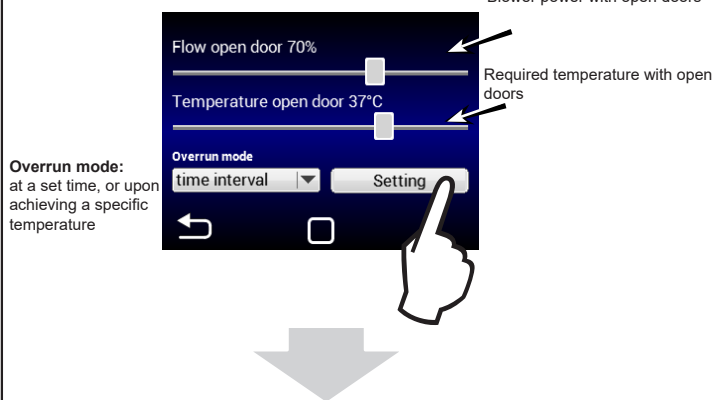

Blower power with open doors

Required temperature with open doors

Overrun mode: at a set time, or upon achieving a specific temperature

7. CONTROL

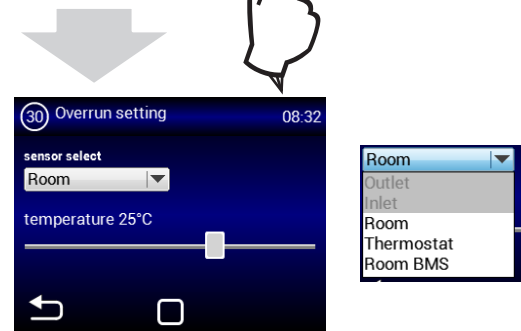
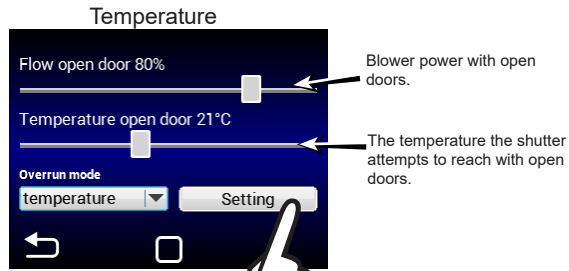
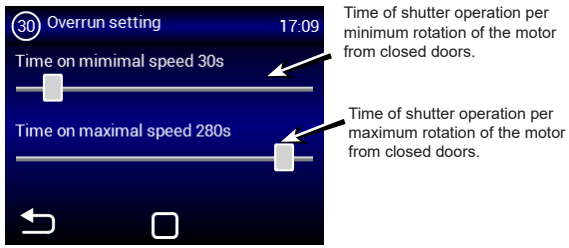

In this menu it is possible to specify which sensor will be active and the temperature the shutter will attempt to reach after closing doors so as to balance temperature loss. After reaching the set temperature, the shutter transitions into the selected automatic/manual mode.

MENU Selflearning

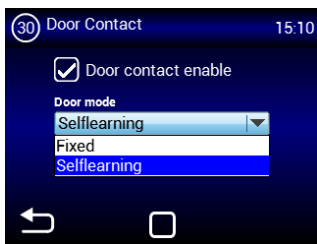

Self-learning - available only in automatic mode and active function (Auto speed control) optimizes the time when the curtain is in operation even when the vortex is closed.

Need to set to activate Selflearnig.

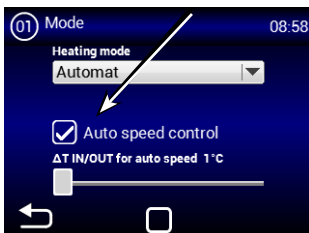

MENU - WATER ANTIFREEZE

The menu is enabled only in units with water exchanger

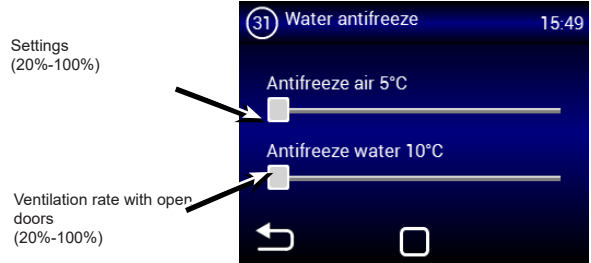

MENU - SUBUNITS

Use this menu to set the behaviour of the IC-S regulators connected as SLAVE

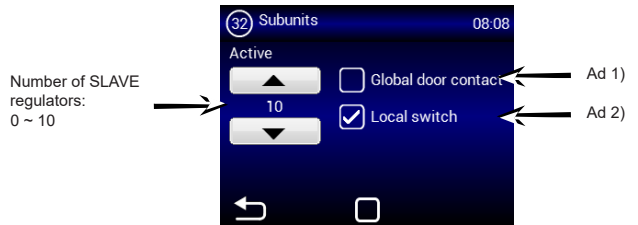

Slave address parameter:

ADDRESS	SLAVE UNIT	ADDRESS	SLAVE UNIT
1	1	6	6
2	2	7	7
3	3	8	8
4	4	9	9
5	5	A	10

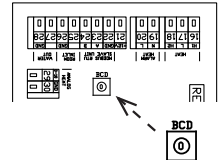

Ad 1) – Use one door contact as main. Its status will be sent to the SLAVE regulators and it will no longer be necessary to connect it to each regulator, if required.

- Not allowed = the door contact will not transmit to the SLAVE regulator from the MASTER
- Allowed = the door contact will transmit to the SLAVE regulator from the MASTER

Ad 2) – Activates in the main screen the icon to turn each SLAVE regulator ON/OFF. If inactive, all the SLAVE regulators will be turned on or off simultaneously.

- Not allowed = The SLAVE regulators are turned on/off simultaneously
- Allowed = The SLAVE regulators can be turned on/off individually from the main screen

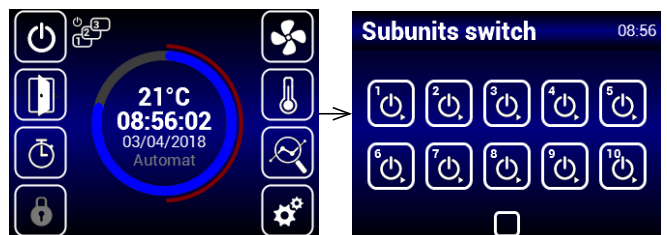

7. CONTROL

MENU - Adv. WATER SETTING

This MENU is available only for units with water heat exchanger it allows for advanced setting of water heat exchanger regulation.

MENU - Adv. fan setting

The MENU for setting the blowers when closing and opening doors. It allows for advanced settings of blower control.



The set limits on blower power restrict the extent of fan control for open and closed doors. This restriction is applied to manual and automatic control of blower power. Exceeding limits in any blower power setting is signalled when the setting element turns red with the text overruns.

Display mode of Menu Adv. fan setting for AC5 and EC

IC3-AC5

IC3-EC

MENU - OTHER SETTINGS

This MENU allows for setting other parameters

Ad 1) - Option to set CAN address of control panel such that up to 2 control panels can be connected to MASTER regulation
Options: CP 1 = control panel has address 1
CP 2 = control panel has address 2

! ATTENTION

Each panel must have its own address.
If this is not observed, it can result in improper functioning of the regulator.

When connecting multiple panels it is necessary to set the termination elements. These can be found on the main electronics and in the control:

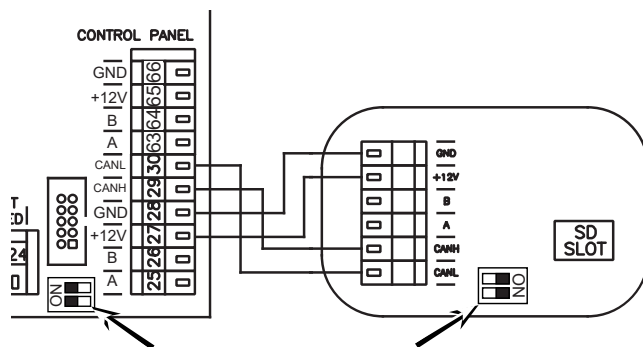

Setting termination elements

Example of connecting controllers - Option 1:

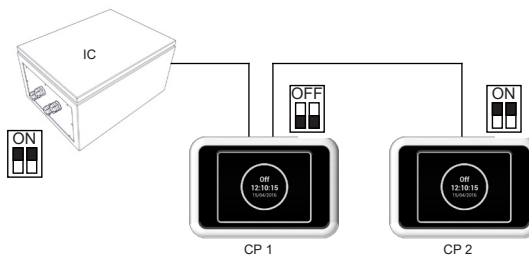

Electrical connection - Option 1:

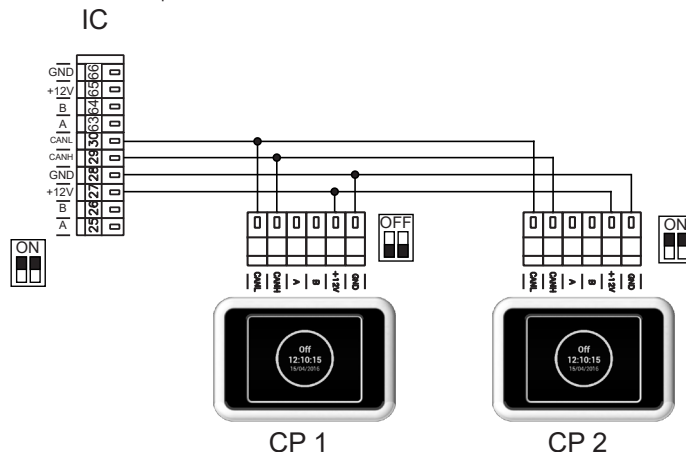

7. CONTROL

Electric connection – Option 2:

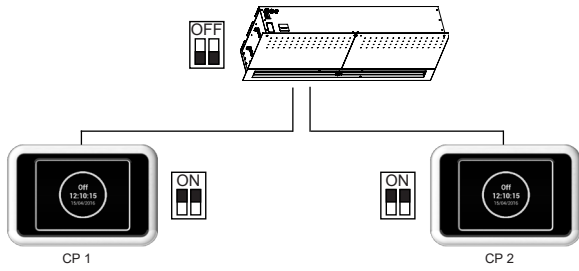

Electric connection – Option 2:

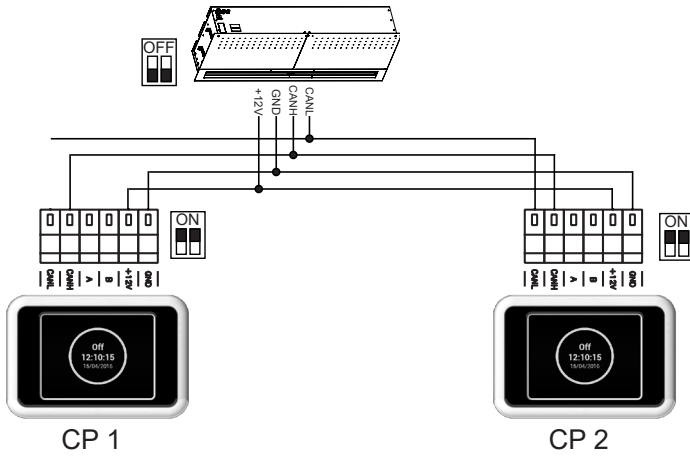

MENU - FACTORY RESET



Use this to reset the default values



Press "FACTORY RESET" to reset the default values of MENU 1616



Once completed, we recommend to turn the main supply off and on.

8. MALFUNCTIONS

8.1 MALFUNCTIONS

Disconnect the main power supply before any intervention to the unit. If you are not sure of the correct steps, do not attempt to perform any repairs and call a professional service!

Description	Unit behaviour	Likely problem	Solution
44 – Fan error	Unit out of order	Overheated fan or defect on thermal contact of inlet fan	Determine the cause of the overheating (defective bearing, short-circuit...) or replace the motor. Check the thermal contacts from the motor to the regulator.
45 – Mandatory maintenance/filter clogged	Unit operational	Filter clogged or the time to maintenance	Replace filters. After replacing or device maintenance, do not forget to reset the MENU 1616 – FILTER TIMER
46 – Heater malfunction	Unit out of order	Heater malfunction	Check the heater and the condition of the safety thermostat Does the heater have proper cooling? Check engine running.
47 - malfunction in external temperature sensor (45,46)	Unit out of order	Temperature sensor malfunction on terminals 45,46	Check that the sensor is correctly connected to the electronics or test it measuring its resistance (the resistance value at +20°C is around 10kΩ)
48 – Outlet temperature sensor malfunction (49,50)	Unit out of order	Temperature sensor malfunction on terminals 49,50	Check that the sensor is correctly connected to the electronics or test it measuring its resistance (the resistance value at +20°C is around 10kΩ)
49 – Inlet temperature sensor malfunction (51,52)	Unit out of order	Temperature sensor malfunction on terminals 51,52	Check that the sensor is correctly connected to the electronics or test it measuring its resistance (the resistance value at +20°C is around 10kΩ)
60 – Exchanger's return sensor malfunction (53,54)	Unit out of order	Temperature sensor malfunction on terminals 53,54	Check that the sensor is correctly connected to the electronics or test it measuring its resistance (the resistance value at +20°C is around 10kΩ)
61 – Room temperature sensor malfunction (55,56)	Unit out of order	Temperature sensor malfunction on terminals 55,56	Check that the sensor is correctly connected to the electronics or test it measuring its resistance (the resistance value at +20°C is around 10kΩ)
62 - malfunction in external temperature sensor from BMS	Limited operation of the device	Temperature sensor malfunction in BMS	Check that in the BMS that the address where the sensors sends the data is properly set (on the right regulator) Check the function of the sensor in the BMS
63 - malfunction in room temperature sensor from BMS	Limited operation of the device	Temperature sensor malfunction in BMS	Check that in the BMS that the address where the sensors sends the data is properly set (on the right regulator) Check the function of the sensor in the BMS
79 – Heating reduced due to low air flow	Unit operational	Only information	The air flow settings were reduced, limiting the heater output to prevent overheating
65 – Communication error	Unit out of order	Communication error	Check the communication cable for damages and if it is properly connected Observe the wiring diagram to prevent occurrences that may disrupt communication (wiring near high tension, phenomena on site causing disruptions)
Unit's not working	Unit out of order	Power supply interrupted	Check that the power supply is not interrupted
		Blown fuse	Check the fuse in side the control module
The heating switches off automatically	Unit operational but not heating	The heater overheats	The heater overheats due to insufficient air flow. Check that the ventilators are in good order and that the air supply is not disrupted.

9. MAINTENANCE

9.1 CLEANING

CAUTION!

- Do not use compressed air, chemicals, solvents or water to clean the unit.
- Use a soft brush or a vacuum cleaner to clean the suction cover and the inside of the unit.
- See the installation manual of the ESSENSSE NEO curtain

10. SERVICE

10.1 IF YOU ARE UNABLE TO REPAIR THE UNIT

If you were unable to solve a problem, contact the supplier or the representative of 2VV. Warranty and post-warranty service are provided by the supplier or an authorised service included in the list available at the supplier's.

Give the following information to the supplier or service:

- **type designation of the air curtain**
- **accessories in use**
- **place of installation**
- **serial number**
- **conditions of the installation (incl. electrical)**
- **period of operation**
- **detailed description of the malfunction**

10.2 – DECOMMISSIONING THE PRODUCT – LIQUIDATOIN

Before scrapping the product, make it unusable. Old products still have raw materials that can be reused. Take them to a collection centre for secondary raw materials. It is preferable to have the product liquidated by a specialist so that the recyclable materials may be reused. Take the unusable parts to an appropriate waste disposal site.



The liquidation of materials must observe the applicable waste management regulations.

11. WIRING DIAGRAM

IC3*-AC-*

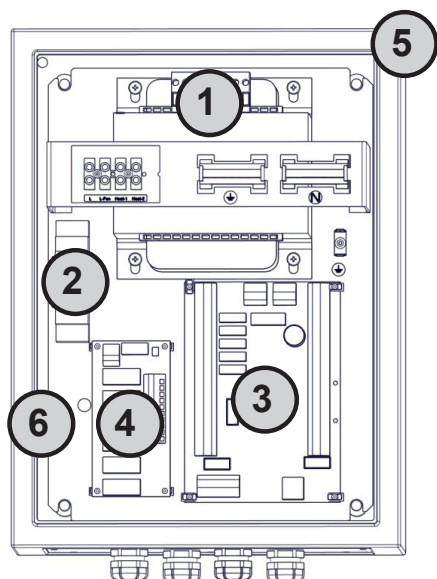

Označení	Popis
1	Transformer (4A / 7A / 16A)
2	Power supply
3	PCB modul A
4	PCB modul AC
5	Box
6	Relé SSR (only 16A type)

IC3*-EC-*

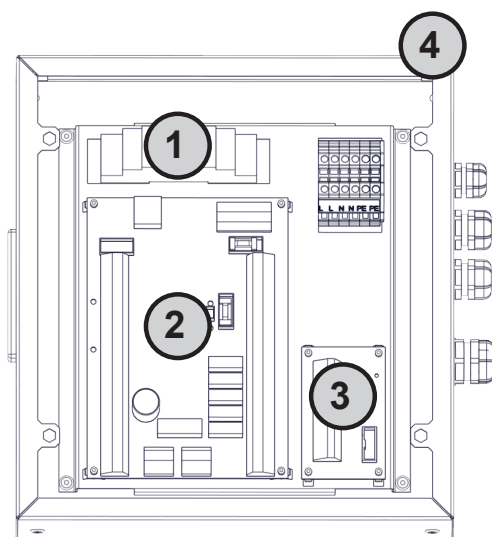

Označení	Popis
1	Power
2	PCB modul A
3	PCB modul TACHO
4	Box

11. WIRING DIAGRAM

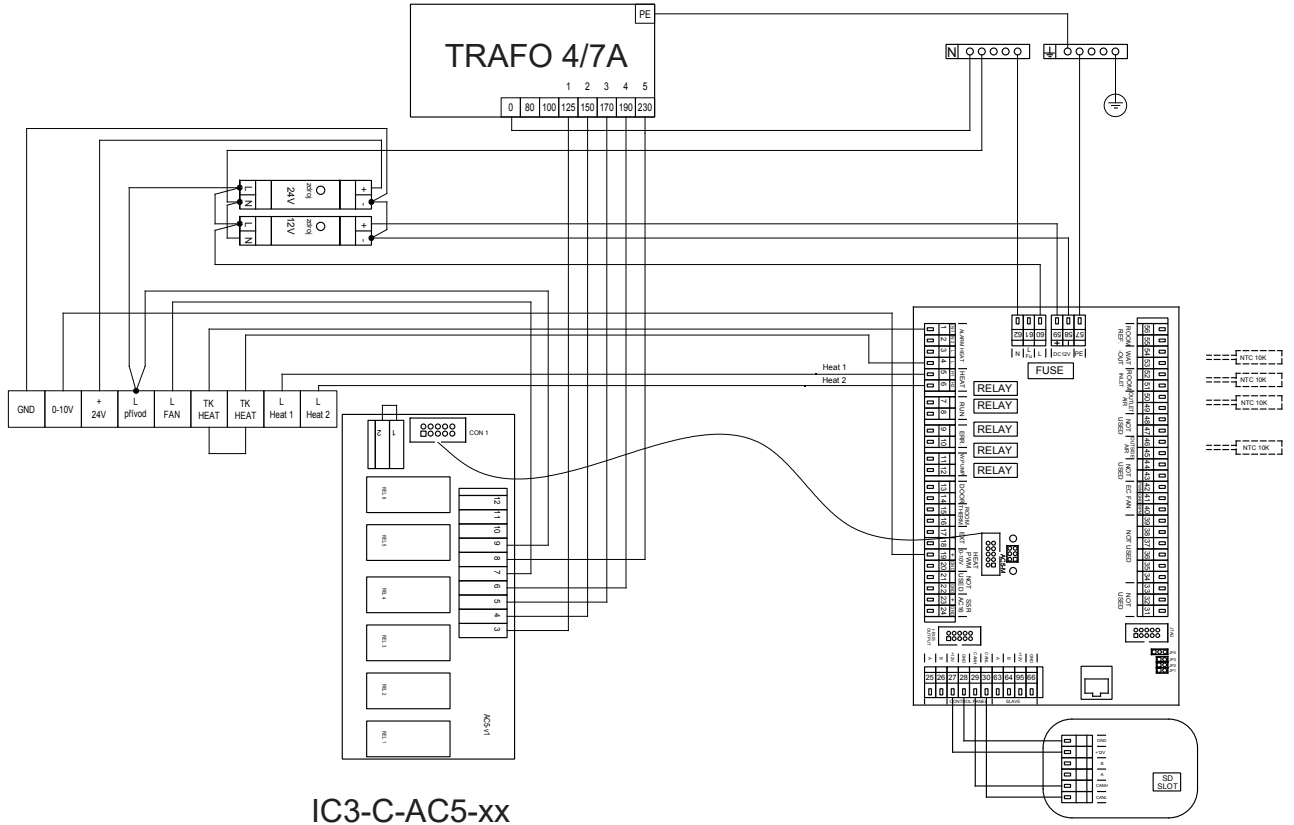

IC3-C-AC5-xx

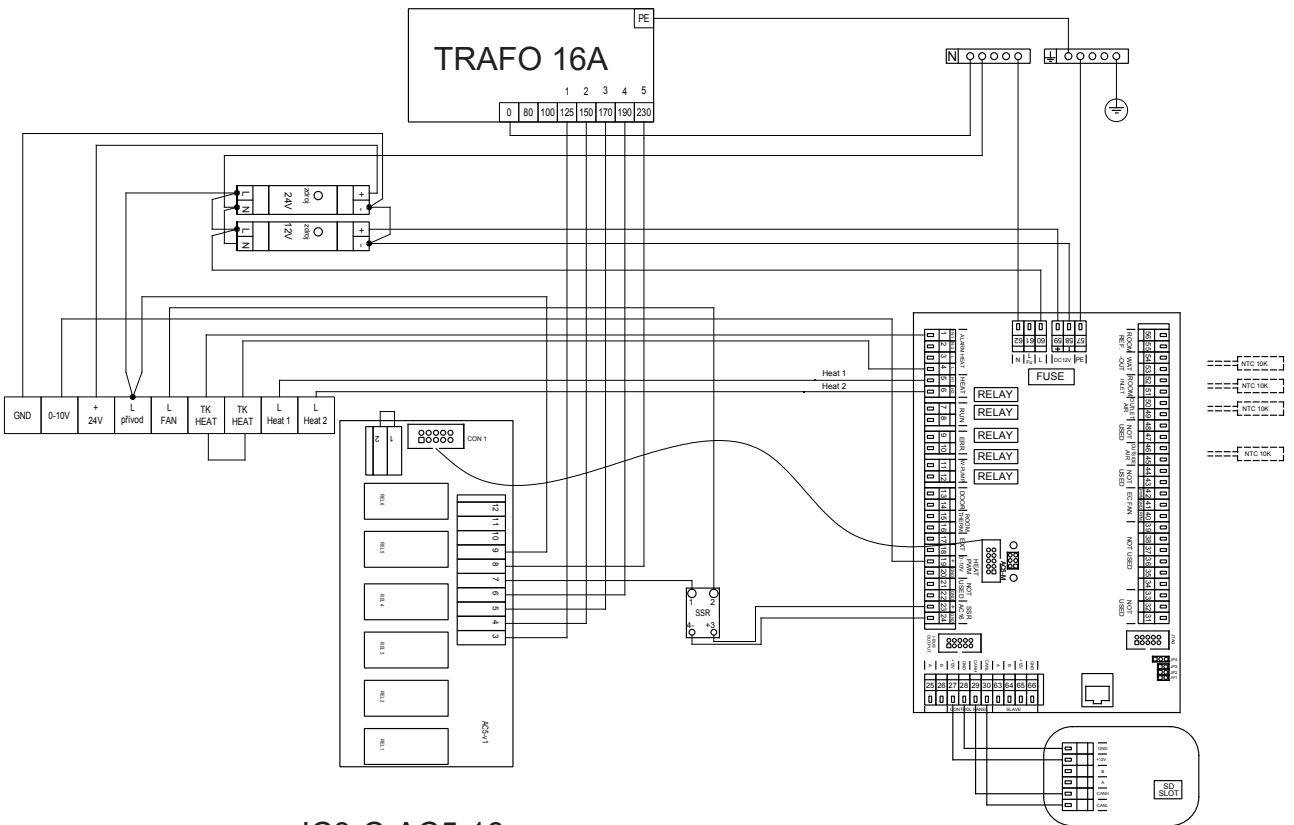

IC3-C-AC5-16

11. WIRING DIAGRAM

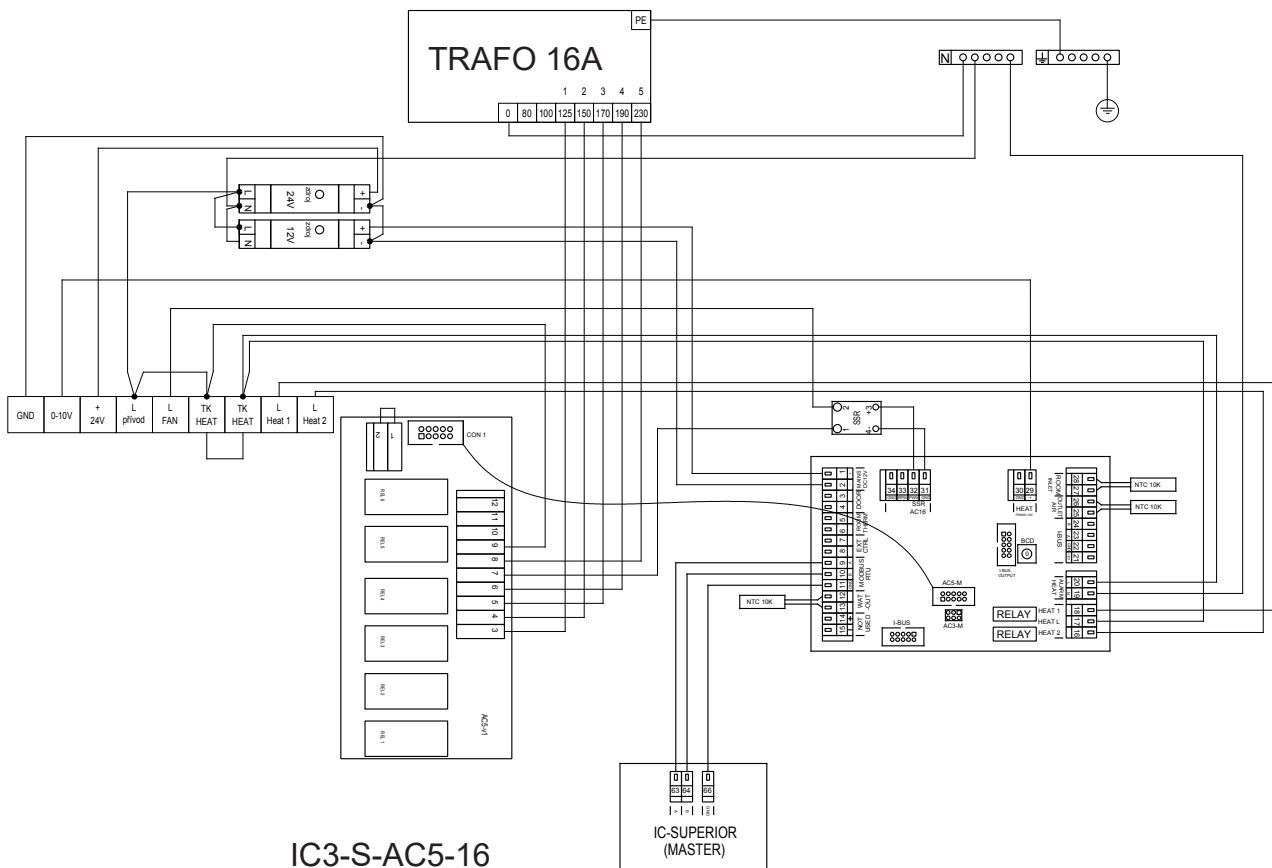
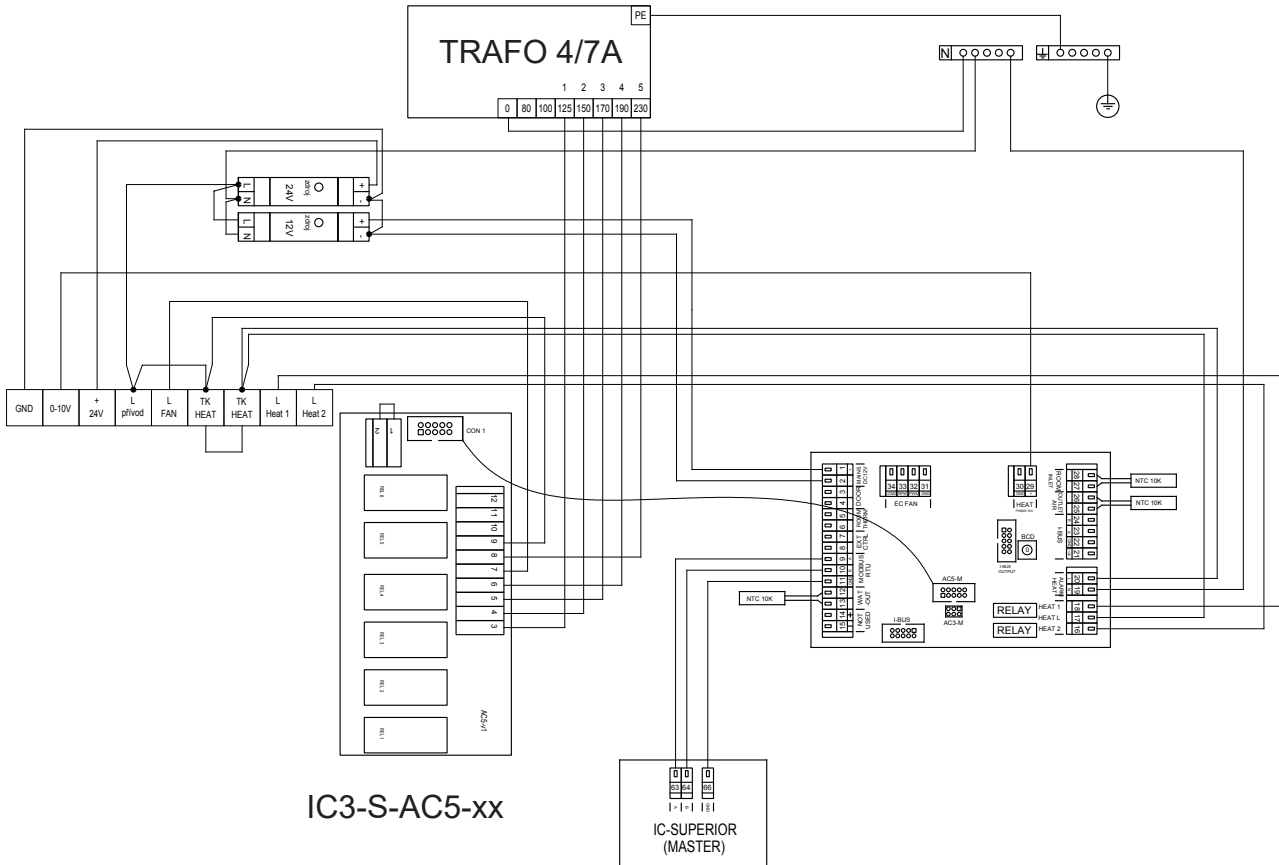

11. WIRING DIAGRAM

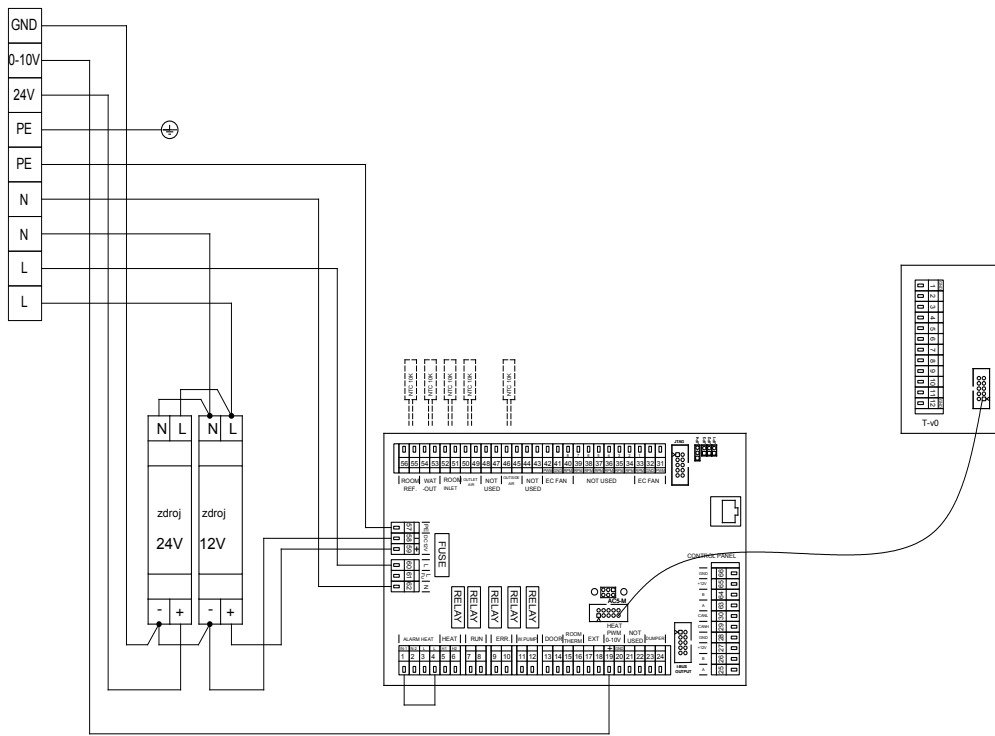

IC3-EC-C

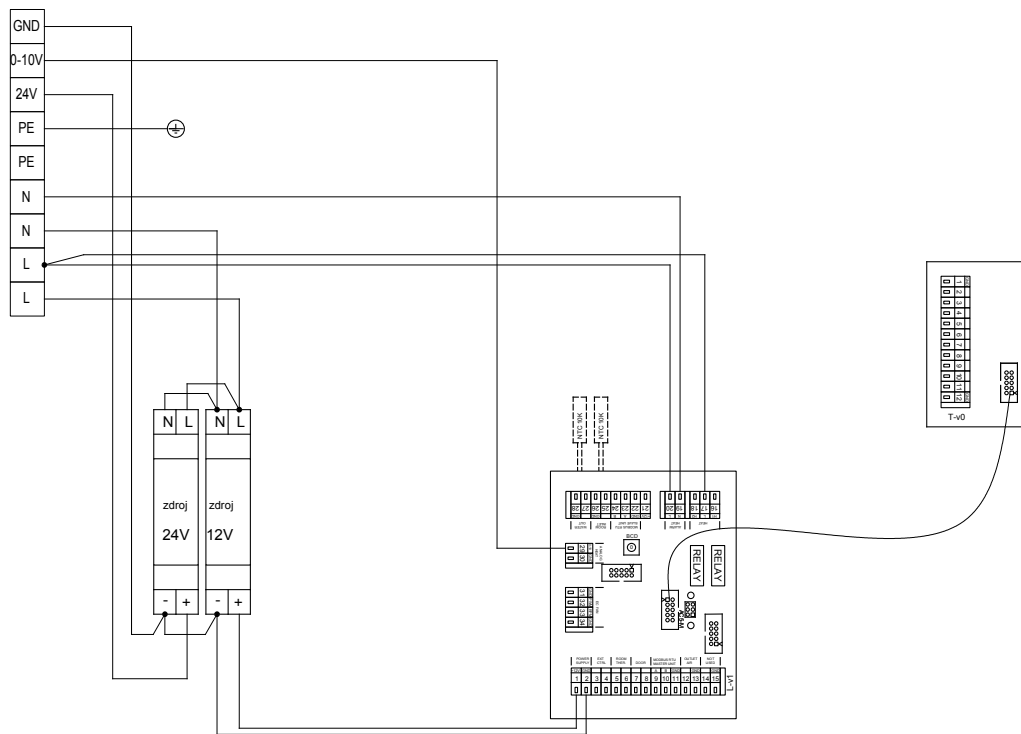

IC3-EC-S

12. CONCLUSION

12. CONCLUSION

In case of any doubt or query, do not hesitate to contact our sales or technical support departments.

CONTACT

Address:

2VV, s.r.o.,
Fáblovka 568,
533 52 Pardubice,
Czech Republic

Internet:

<http://www.2vv.cz/>

