



PARTNER
IN VENTILATION
2VV.CZ

EN

IC-ModBus

INSTALLATION AND SERVICE MANUAL

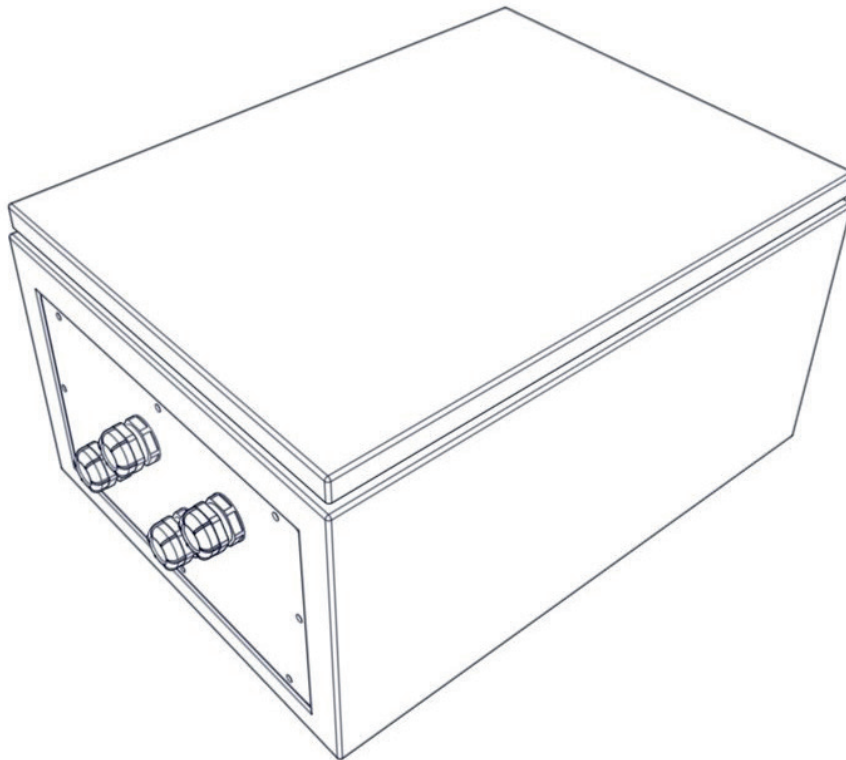

P04-0221-0216-00







H04-0221-0216-00

1/1

1. BEFORE YOU BEGIN

For better orientation in the manual, there are various symbols used in the text. The following table shows their portrayal and meaning.

Symbol	Meaning
 ATTENTION!	Warning or notice
 IMPORTANT NOTICE!	Important instructions
 YOU WILL NEED	Practical tips and information
 TECHNICAL INFORMATION	More technical information
	Link to another part of the manual



Before installation, properly read the manual how to safely and properly use this product.

This manual contains instructions for proper installation of the regulation. Before installation of the regulation, please properly read the whole manual. The manufacturer reserves the right to make changes, including the technical documentation without prior notice. Please save this manual for future use. The service manual is a part of the product.

Conformity declaration

The product has been designed, manufactured, placed on the market, complies with all applicable regulations and is in compliance with the requirements of the directives of the European Parliament and the Council, including amendments to the proposal, under which it was classified. Under normal conditions and in the instruction manual for the intended use and installation, it is safe. The harmonized European standards referred to in the relevant ES declaration of conformity have been applied in the assessment. For the current and full version of the ES Declaration of Conformity, please see www.2vv.cz

2.UNPACKING

2.1 CHECK THE DELIVERY

IMPORTANT NOTICE!

- Immediately after receiving the delivery, check if the product is damaged. In case of damage make a record with the forwarder.
- If the claim is not made in time, it will not be possible to guarantee possible future claims. Check whether the delivered type of product matches the ordered one. In case of disagreement, do not unpack the unit and report this fact to the supplier.
- After unpacking, check whether the unit and other parts are all right. If in doubt, contact the supplier.
- Never try to put a damaged product into operation.
- If a product is not unpacked immediately after delivery, it has to be stored in a dry interior with a maximum temperature range from **+5 °C to +40 °C**.
- This product should not be used by persons (including children) whose physical, sensory or mental disability or lack of experience and knowledge is insufficient for the safe use of the product, if they are not supervised or instructed on how to use the product by a person responsible for their safety.
- Do not allow children to play with the product.

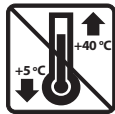

	All used packaging materials are ecological and re-usable or recyclable. Please contribute actively to environmental protection and ensure the regular disposal or re-use of the packaging materials.	
--	---	--

2.2 UNPACK THE UNIT

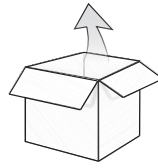

IC-ModBus regulation box

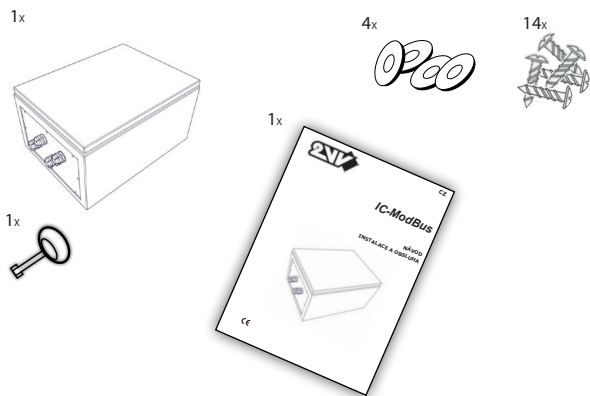

IMPORTANT NOTICE!

- If the product was transported at a temperature below 0 °C, it is necessary to leave it for at least 2 hours at rest, for temperature compensation inside the product to occur.

3. MAIN PARTS

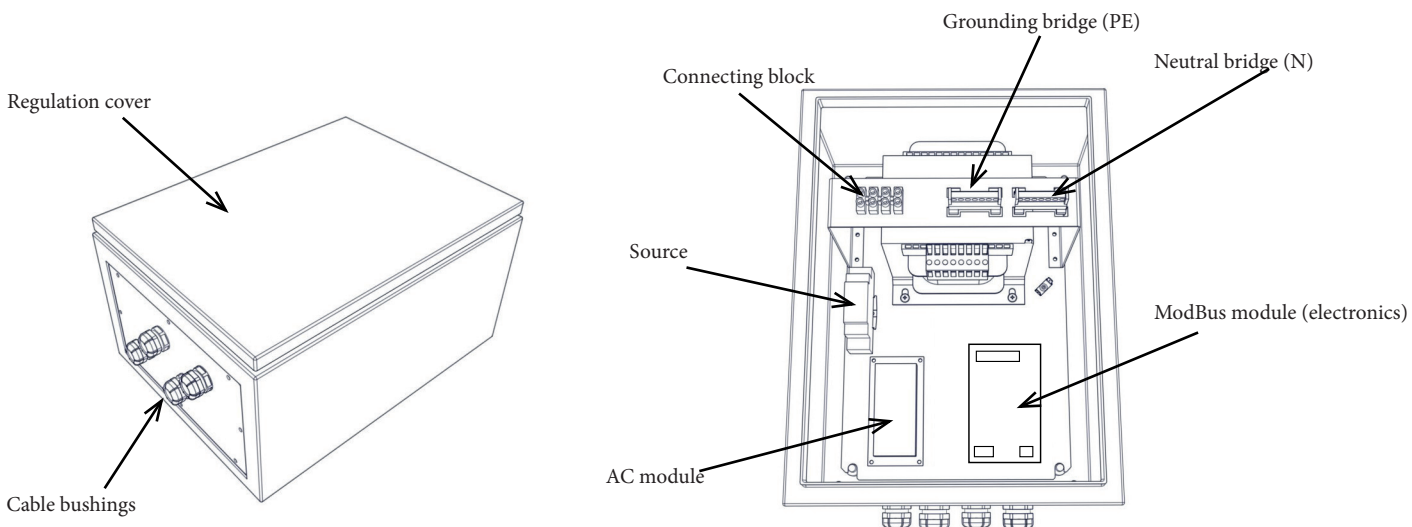

4. DIMENSIONS

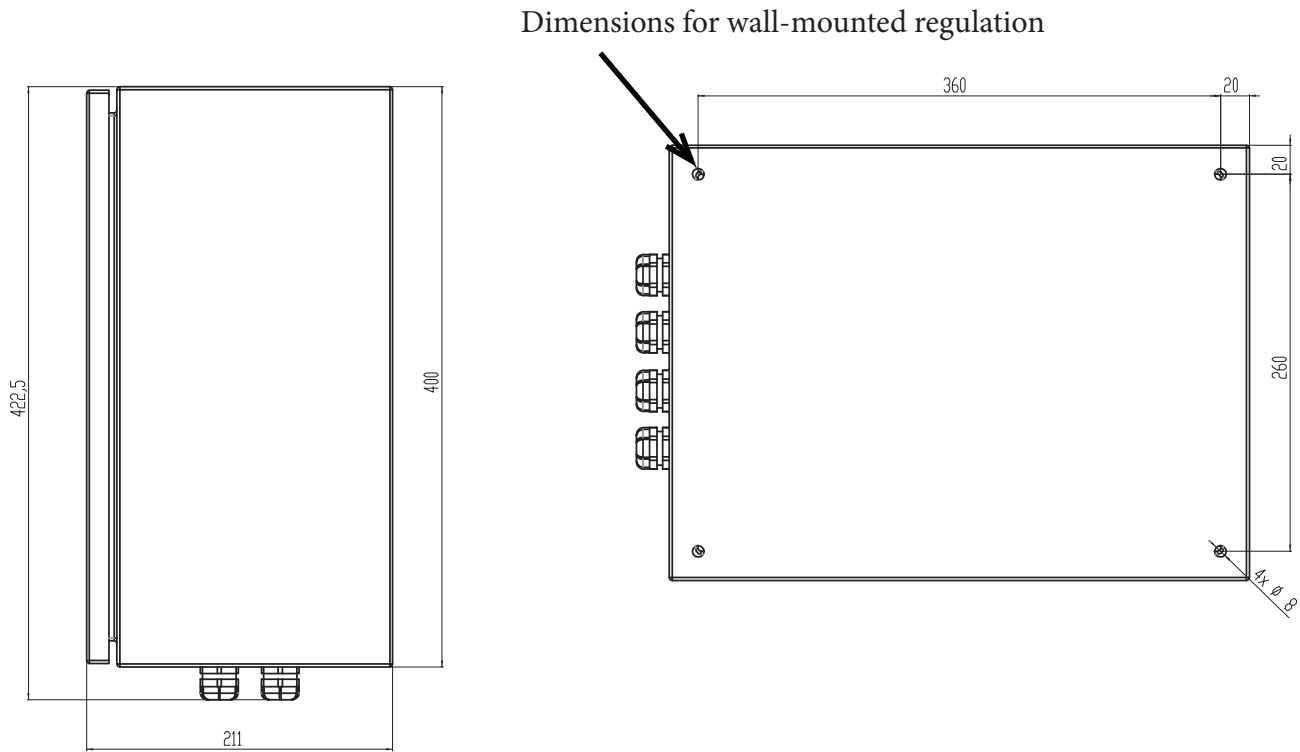

5. TECHNICAL SPECIFICATIONS

Type	Number of phases [pcs]	Voltage [V]	Frequency [Hz]	Max. fans current [A]	Weight [kg]
IC-M-AC5-04	1	230	50/60	4	13,5
IC-M-AC5-07	1	230	50/60	7	15
IC-M-AC5-16	1	230	50/60	16	23

6. INSTALLATION

6.1 CHOOSE THE PLACE OF INSTALLATION



The assembly and especially wiring of the control unit can be executed only by a trained person with appropriate authorization for the wiring of electric devices, who has suitable tools and means available. During assembly, it is necessary to follow all instructions and recommendations listed in this manual.

TECHNICAL INFORMATION

The regulator must be operated at places corresponding to the IP cover.

6.2 ASSEMBLY TO THE OPERATIONAL POSITION

The regulator is intended to be installed on a wall in the vertical position. The regulator must be installed in such a way that the air can flow around to prevent overheating. Comply the minimum recommended standoff distances. The regulator must be installed in such a way that ensures sufficient access for maintenance, service and disassembling. The regulator is attached using screws and dowels on a wall or bolts. There must not be any flammable materials within a distance of 100 mm from the regulator.

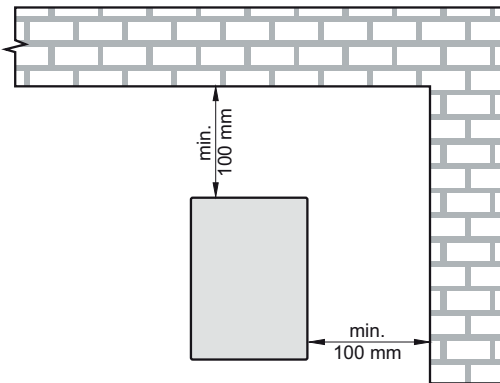

TECHNICAL INFORMATION

After installation of the regulator on the wall, we recommend separating the inner part (electronics+transformer) from the regulation box for easier manipulation.

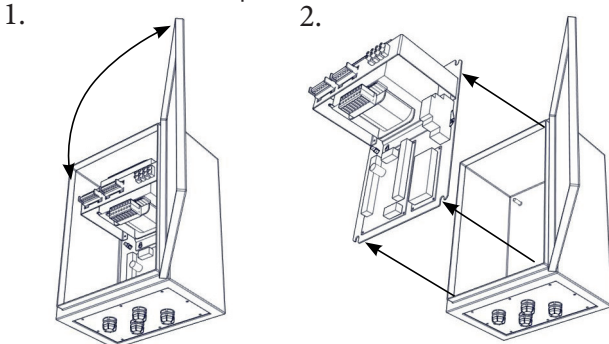

The regulation must be installed in the way shown in the above pictures, thus bushings downwards.

- Use corresponding screws and dowels for attaching the regulator.
- For maintaining the IP cover of the box, use bolts and the supplied washers.



- Driller
- 4x bolts
- 4x dowels
- 4x sealing washers (a part of the delivery)

6.3. ELECTRICAL WIRING AND ELECTRICAL ASSEMBLY

ATTENTION!

- The regulator must be disconnected from the main electric power supply before any intervention.
- The current installation can be executed only by a professional with education focused on electric.
- The service manual must be monitored together with the valid state regulations and directives.
- The unit must be connected to the main power supply using isolated, thermally resistant cable which is in accordance with the diameter and corresponding state regulations and directives.
- All phases of the electric supply to the regulator must be connected via a protective power circuit breaker of the corresponding current and type.



- The distance between unfastened contacts must be greater than 3 mm.
- The nominal values of electrical parameters of the unit are listed on the manufacturing label.
- The main electric power supply, switched elements and accessories are connected according to the wiring diagram.
- The connected fans must not exceed the nominal current value of the unit!
- Any interventions and changes in inner wiring of the control unit are not allowed and lead to a loss of warranty.
- In case of fire, it is necessary to extinguish the device using a powdered or CO2 fire extinguisher.
- The unit must be connected in such a way that allows disconnecting from the source using only one element.

Table of minimum dimensioning of circuit breakers according to the type of unit.

Recommended circuit breakers:

Circuit breakers	
IC-M-AC5-04	6A
IC-M-AC5-07	10A
IC-M-AC5-16	20A

6. INSTALLATION

6.4. DESCRIPTION OF CONNECTORS

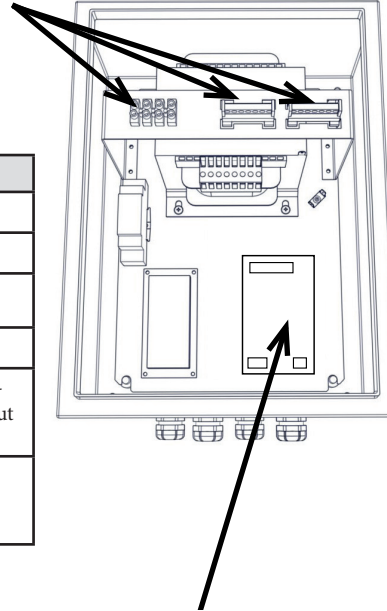
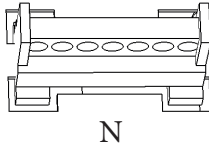
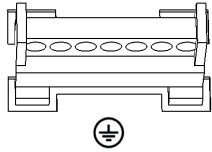
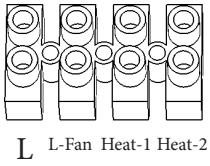

	Description (electric heat)	Description (water heat)
L	Power supply phase (230V)	
N	Neutral bridge (N)	
⊕	Grounding bridge (PE)	
L-Fan	Fan control phase (output)	
Heat -1	Heating degree 1 (electric heat - output 230V with I _{max} 3A)	* Controlling voltage of the actuating mechanism (water heat - output 230V)
Heat -2	Heating degree 1 (electric heat - output 230V with I _{max} 3A)	N/A

* In case of water heat, only the Heat-1 output is active

Connector No.	Description
5-4	DOOR - Digital input (eg. door contact)
6	A - ModBus A
7	B - ModBus B
8	GND - ModBus GND
9-10	T-EXT-1 - Temperature sensor
15	GND - GND for EC motor
16	PWM - PWM for EC motor 0-10V(adjustable factory driver 10005)
17	TACHO (EC motor)

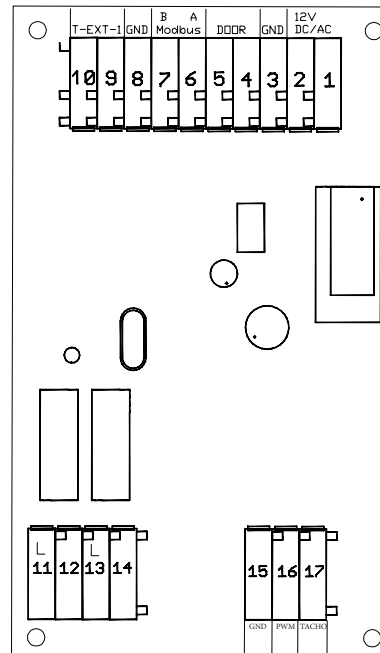

IC - ModBus is ready for control of AC and EC motors

6. INSTALLATION

6.5. EXAMPLE OF WIRING OF SHUTTER WITH ELECTRIC HEAT

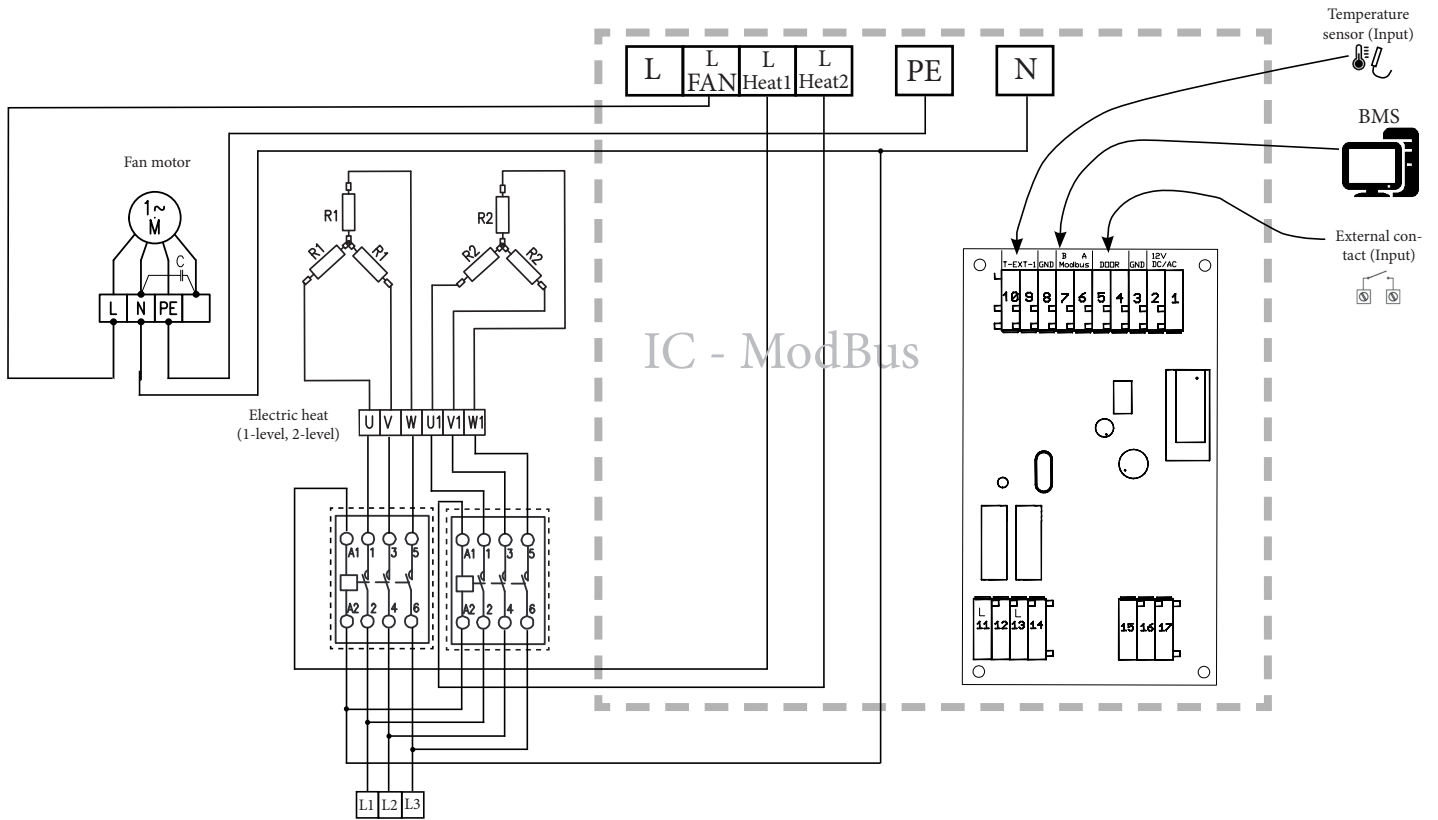

6.6. EXAMPLE OF WIRING OF SHUTTER WITH WATER HEAT

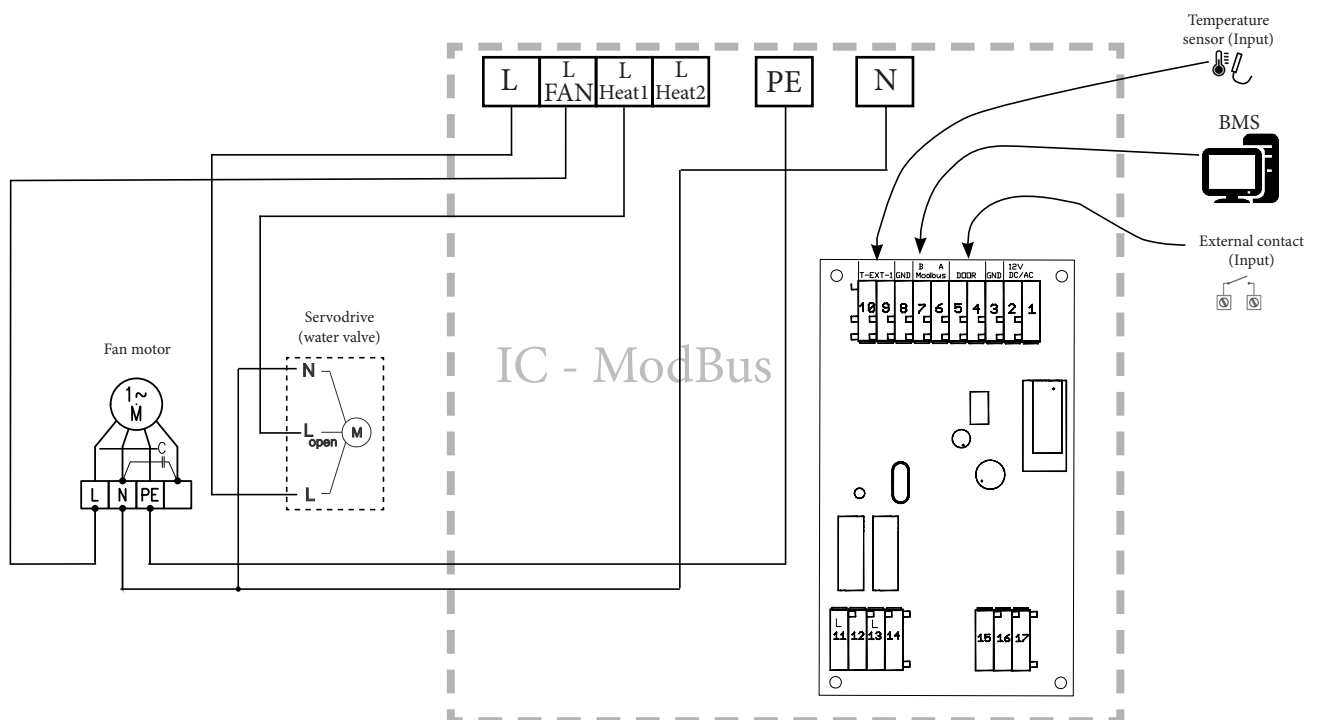

7. CONTROL

7.1. COMMUNICATION PROTOCOL - MODBUS RTU

*Address of module 0x01

Operational parameters of communication line RS485 MODBUS (RTU):

- 9600Bd
 - 1 start bit
 - 8 data bits
 - 1 bit even parity
 - 1 stop bit
- Each module must support even parity. If parity is not used, it is replaced by second stop bit.

Communication method:

- Master – control system (BMS)
- Slave – electronics Module D (Modbus module)



Only the control system can be connected.
 After the first connection of power supply, the module is in the OFF state. The requested operational mode must be sent by the superior control system! After the subsequent disconnection of the power supply, the module remembers its last operational mode.

Communication connector numbers:

- A - 6
- B - 7
- GND - 8

MODBUS RTU:

In the RTU mode, every 8-bit byte of message contains two 4-bit hexadecimal characters. The transmission of a message must be continuous, the spaces between the characters must not be longer than 1.5 character. The beginning and end of the message is identified according to the bus rest longer than 3.5 character. The RTU frame format is shown in the picture.

General structure of telegram [hex]:

Beginning	Address	Function	Data	CRC	End
> 3.5 characters	8 bits	8 bits	N * 8 bits	16 bits	> 3.5 characters

Data block length

Size of **ADU on RS-485** = 253 bytes PDU + address(1 byte) + CRC (2 bytes) = **256 bytes**

Address

Master has not any specific address, only slave units have to have an address unique in all MODBUS site.

CRC

Field with generating polynom $x^{16} + x^{15} + x^2 + 1$.

7.2. TABLE OF KEY CHARACTERS AND CONFIGURATION DATA

Factory Driver:

Intended for hardware setup (READ/WRITE)

Address	Name	Info	Min. Value	Max. Value	Default
Factory set register - without valid FactoryPass only read					
10001	AC_Switch	0 - AC3 1 - AC5	0	1	0
10002	MaxFlowManual	% of fan power	70	100	100
10003	MinFlowManual	% of fan power	0	40	20
10004	Postheat_1	0 - none 1 - electric 2 - water	0	2	0
10005	MotorEC_set	0 - PWM 1 - analog (0-10V)	0	1	0
10006	TempEXT1	0 - non 1 - used	0	1	0



At the IC-ModBus regulator, it is necessary to always set AC5 on address 10001 (five-degree module)

7. CONTROL

Address	Name	Info	Min. Value	Max. Value	Default
10007	Modbus Baudrate	0-4800 1-9600 2-19200 3-38400	0	3	1
10008	Modbus Parity	0-NONE 1-ODD 2-EVEN	0	2	2

Service hardware:

Intended for additional functions setup (READ/WRITE)

Address	Name	Info	Min. Value	Max. Value	Default
Service register - (Factory reset no effect)					
25000	Modbus1	Modbus adres port 1	1	247	1
25001	HeaterCoolDownTime	minutes	1	5	5
25002	HeaterCoolDownFlow	%	Factory_Driver 10003	Factory_Driver 10002	20
25003	LostCommunicattion-Protect		0	1	0

info:

(Status register - READ ONLY)

Address	Name	Info	Min. Value	Max. Value	Default
Status register - read only (Factory reset no effect)					
15000	UnitStatus	0-OFF 1-ON 2-COOLDOWN	0	2	
15001	Sensor Status	1 - TempEXT1_Error 0 - TempEXT1_OK	0	1	
15002	StatusDI1	1 - DI_open 0 - DI_closed	0	1	
15003	StatusDI2	1 - DI_TACHO_pulzy 0 - DI-TACHO_error	0	1	
15004	AirFlowFanManual	0% = OFF 1%-20% = 1. speed 21% - 40% = 2. speed 41% - 60% = 3. speed 61% - 80% = 4. speed 81% - 100% = 5. speed	0	100	
15005	AirFlowFanManualEC	0% = OFF 1% - 100% = % PWM	0	100	
15006	PowerPostheater1	Electric version: 0% = OFF, 1% až 50% = Heat1, 51% až 100% = Heat2 Water version: 0% = OFF, 1 až 100% = Heat1	0	100	
15007	TempEXT1	°C (temp * 10)	-400	1000	
15008	TempEXT1	°F (temp * 10)	-400	2120	

7. CONTROL

Control:

Control (READ/WRITE)

Address	Name	Info	Min. Value	Max. Value	Default
Share register					
21000	SwitchON	0 - OFF 1 - ON	0	1	0
21001	AirFlowManual	0% = OFF 1% - 20% = 1. speed 21% - 40% = 2. speed 41% - 60% = 3. speed 61% - 80% = 4. speed 81% - 100% = 5. speed	Factory_Driver 10003	Factory_Driver 10002	-
21002	AirFlowManualEC	0% = OFF 1% - 100% = % PWM	Factory_Driver 10003	Factory_Driver 10002	-
21003	HeatManual	Electric version: 0% = OFF, 1% až 50% = Heat1, 51% až 100% = Heat2 Water version: 0% = OFF, 1 až 100% = Heat1	0	100	0

Negative answers:

If a client sends a request to the server, he expects an answer. Four situations may occur:

- If a server receives a request flawlessly and is able to process it normally, it returns a normal answer to the client.
- If a server does not receive a request due to a communication failure, it does not return any answer. On the side of the client, the time limit for answer receipt expires.
- If a server receives a request but detects a communication failure (parity, CRC...), it does not return any answer. On the side of client, the time limit for answer receipt expires.
- If a server receives a request flawlessly but is not able to process it normally, it returns a negative answer to client, while giving a reason for the failure.

A normal and negative answer are different by the highest bit of the function code. If the bit is null, it is a normal answer, if the bit is set, it is a negative answer. In case of a negative answer, there is a failure code forwarded in the data part. There is a list of possible failure codes in the following table.

7. CONTROL

MODBUS failure codes		
Code	Name	Meaning
01	Illegal function	The requested function is not supported by server
02	Illegal data address	The entered address is out of the range supported by server
03	Illegal data value	The transmitted data is not valid
04	Device failure	An unremovable failure occurred while executing the request
05	Confirmation	Code intended for use at programming. The server reports the reception of a valid request but the execution will take a longer time
06	Device is busy	Code intended for use at programming. The server is busy with executing a long-standing command
08	Memory parity failure	Code intended for use at work with files. Server discovered a parity failure while trying to read the file

Supported telegrams Modbus, Modbus Module*

MODBUS failure codes		
Code	Name	Meaning
03	READ HOLDING REGISTER	according to Modbus standard
04	READ INPUT REGISTER	according to Modbus standard
06	WRITE REGISTER	according to Modbus standard
16	WRITE MULTIPLE REGISTERS	according to Modbus standard

Examples of communication:

Operational data reading:

It is possible to read all operational data of the unit from addresses 15000 to 15008.

Example 1:

Start of the unit, flow rate 60%.

address → value

21000 → 0x01

21001 → 60 (max. flow rate = address 10002)

Turning off the unit:

21000 → 0x00

8. CONCLUSION



For the safe and proper use of the regulation unit, it is necessary to read this manual and follow it.

Regarding any question or request of explanation, do not hesitate to contact our customer service or technical support department.

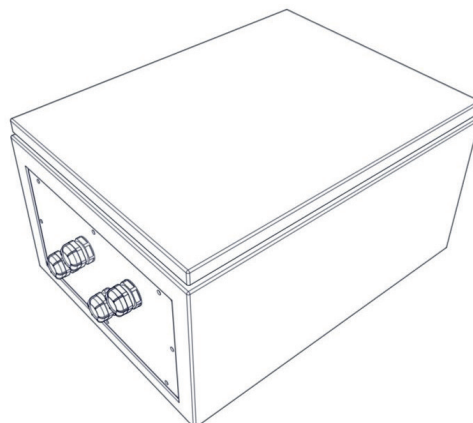

Contact:

**2VV s.r.o., Fáblovka 568
533 52 Pardubice
Czech Republic**

**Internet:
<http://www.2vv.cz>**



Copyright © 2VV
All rights reserved.

The producer is not responsible for damages incurred on the device, which were caused by an inexperienced installation and service, which are contrary with the manual and conventions during installation and service of ventilation units and regulation systems.