



PARTNER
IN VENTILATION
2VV.CZ

EN

SAVANA

AC: SAV-1, SAV-2, SAV-4, SAV-6

EC: SAV-1, SAV-2, SAV-4

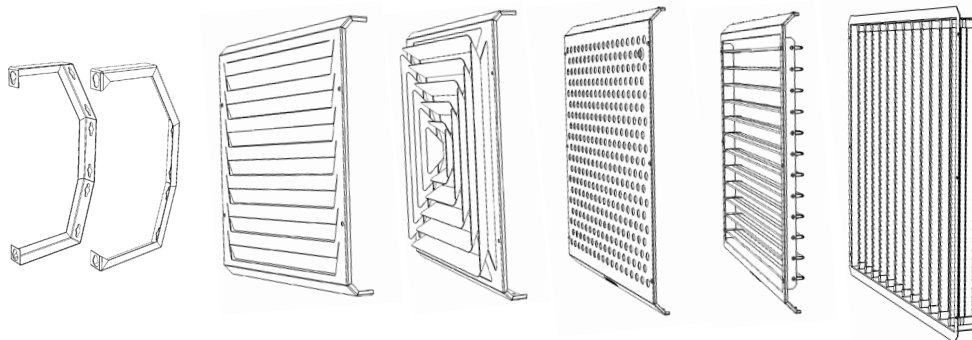
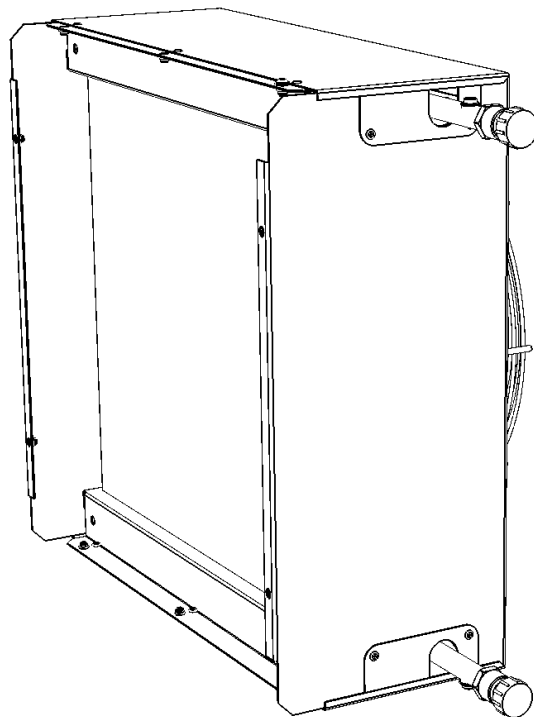

INSTALLATION AND OPERATION

1. BEFORE YOU START

Symbols are used in the text for better orientation in the user's manual. Following table includes their illustration and meaning:

Symbol	Meaning
ATTENTION!	Warning or notification
NOTE WELL!	Important instructions
YOU WILL NEED	Practical tips and information
TECHNICAL INFORMATION	Detail technical information
	Link to other section/part of the manual



This manual includes important instructions for correct installation of **SAVANA** Heat units. Before installation of the heater unit, please read and follow all the instructions below! The manufacturer reserves the right to make changes to the technical documentation without previous notification. Please save the manual for further use. Instructions in this manual should be considered integral part of the product

EC DECLARATION OF CONFORMITY

This manual includes important instructions for correct connection of the ventilation unit. Before connecting the unit, please read and follow all the instructions below! The manufacturer reserves the right to make changes, including the technical documentation, without previous notification. Please save the manual for further use. Instructions in this manual should be considered integral part of the product

For current and full version of the EC Declaration of Conformity see www.2vv.cz.

2. UNPACKING

2.1 CHECK THE SUPPLY



- -After the delivery, check immediately possible damage of the packed product. In case of damaged packaging, contact your forwarding company. Should the claim not be filed on time, no claims may be lodged in the future.
- -Check whether the product Typee corresponds with the order. In case of non-compliance, do not unpack the unit and report the fault to the supplier immediately.
- -After unpacking, please check the condition of the heater unit and other accessories. In case of doubt, contact your supplier.
- -Never install damaged heater unit!
- -If you do not unpack the heater unit immediately after its delivery, it must be stored in a dry indoor environment with the ambient temperature from **+5°C to +35°C**.

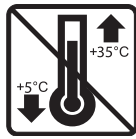

	<p>All used packaging materials are environment-friendly and may be reused or recycled. Contribute actively to the environmental protection and be particular in correct disposal and reuse of packaging materials.</p>	
--	---	--

2.2 UNPACK THE UNIT

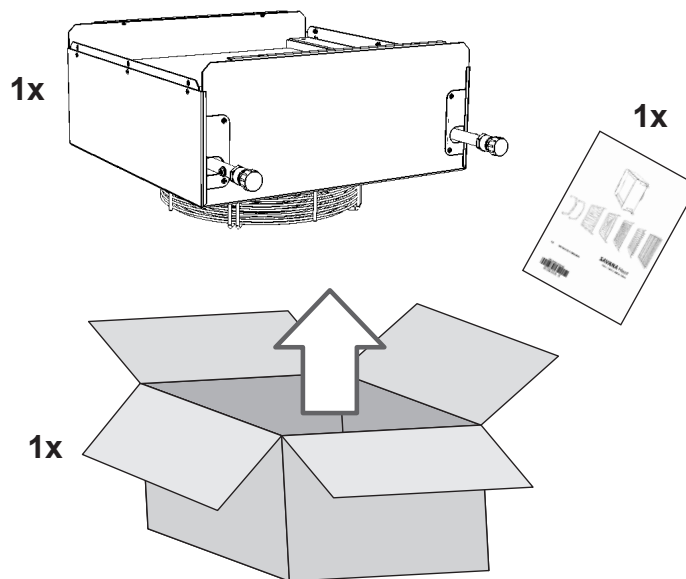

3. MAIN PARTS

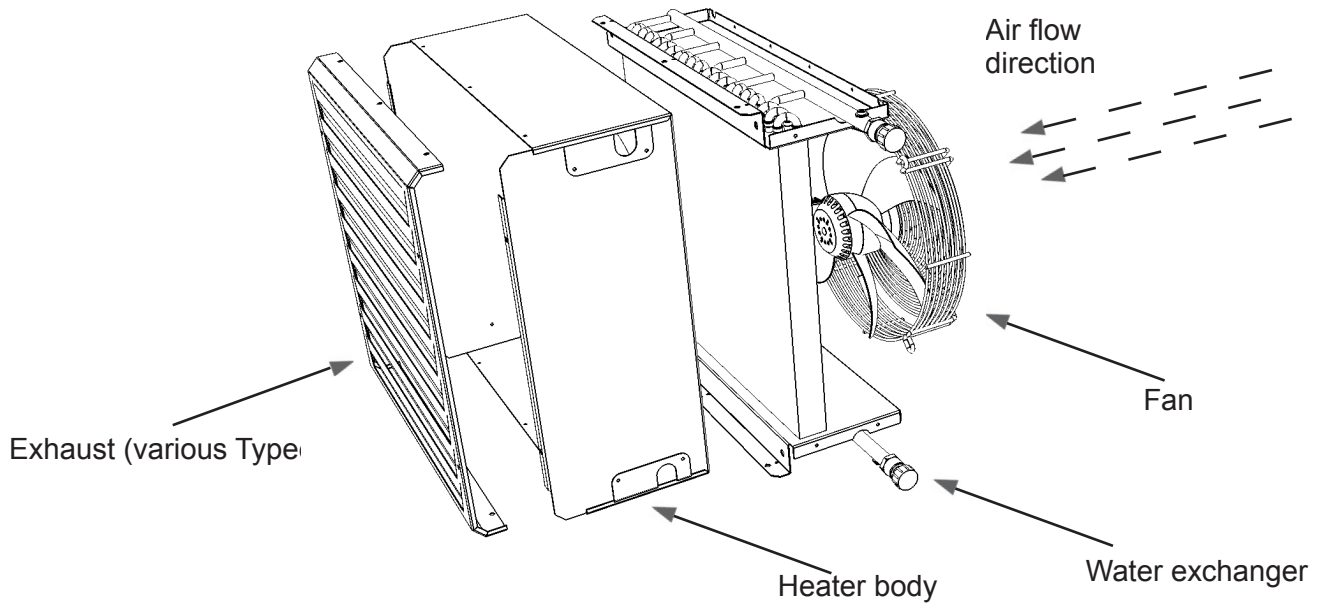

4. DIMENSIONS

Heater body without cover

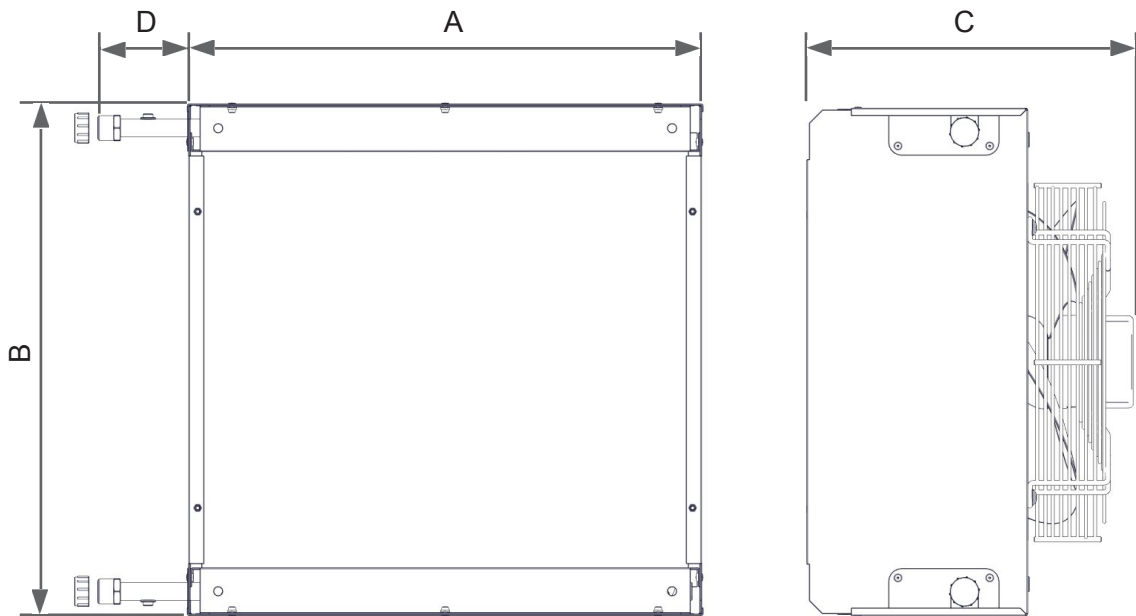

4. DIMENSIONS

Dimensions of the attachment

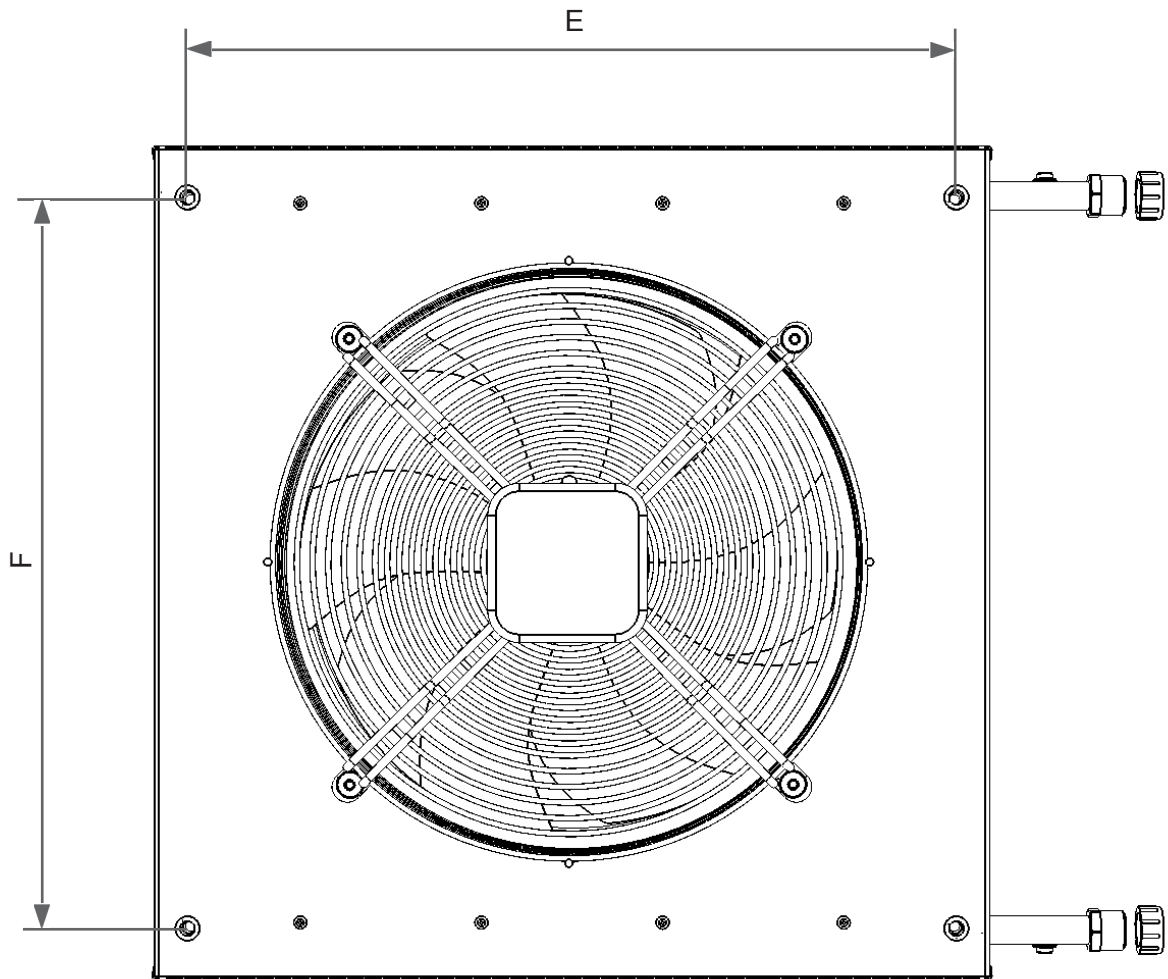

Type	A	B	C	D	E	F
SAV-1-AC	455	455	350	100	408	383
SAV-2-AC	555	555	350	100	508	483
SAV-4-AC	755	755	350	100	708	683
SAV-6-AC	855	855	350	100	808	783
SAV-1-EC	455	455	325	100	408	383
SAV-2-EC	555	555	335	100	508	483
SAV-4-EC	755	755	340	100	708	683

Dimensions in the table are in mm

4. DIMENSIONS

Dimensions of brackets

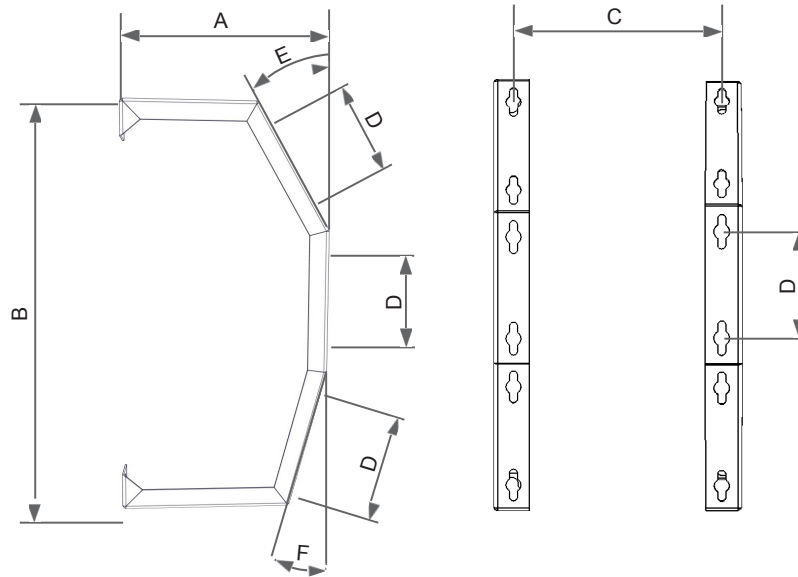

Type	A	B	C	D	E	F
SAV-1	250	452	404	100	30°	15°
SAV-2	280	552	504	130	30°	15°
SAV-4	280	753	704	200	30°	15°
SAV-6	280	853	804	230	30°	15°

Dimensions in the table are in mm

5. TECHNICAL PARAMETERS

Type	Air output	Voltage	Current	Input	Weight**
	[m ³ /h]	[V/Hz]	[A]	[W]	[kg]
SAV-1-2R-AC	1300	230/50	0,65	150	16
SAV-2-2R-AC	2100	230/50	0,95	200	22
SAV-4-2R-AC	4350	230/50	2,00	460	34
SAV-6-2R-AC	5850	230/50	3,00	690	45
SAV-1-2R-EC	1720	230/50-60	1,50	350	16
SAV-2-2R-EC	2550	230/50-60	2,10	455	22
SAV-4-2R-EC	4260	230/50-60	2,20	470	34

Type	Air output	Voltage	Current	Input	Weight**
	[m ³ /h]	[V/Hz]	[A]	[W]	[kg]
SAV-1-3R-AC	1200	230/50	0,65	150	18
SAV-2-3R-AC	2000	230/50	0,95	200	24
SAV-4-3R-AC	4050	230/50	2,00	460	36
SAV-6-3R-AC	5300	230/50	3,20	740	47
SAV-1-3R-EC	1560	230/50-60	1,50	350	18
SAV-2-3R-EC	2280	230/50-60	2,10	455	24
SAV-4-3R-EC	3820	230/50-60	2,20	470	36



Hot-water exchanger made from Cu/Al is designed for max. operating temperature of water +110°C and max. operating pressure 1.6 MPa.

**Weight of the heater unit without water in the exchanger

6. INSTALLATION

6.1 SELECT INSTALLATION POINT

6.1.-1 Development dimensions

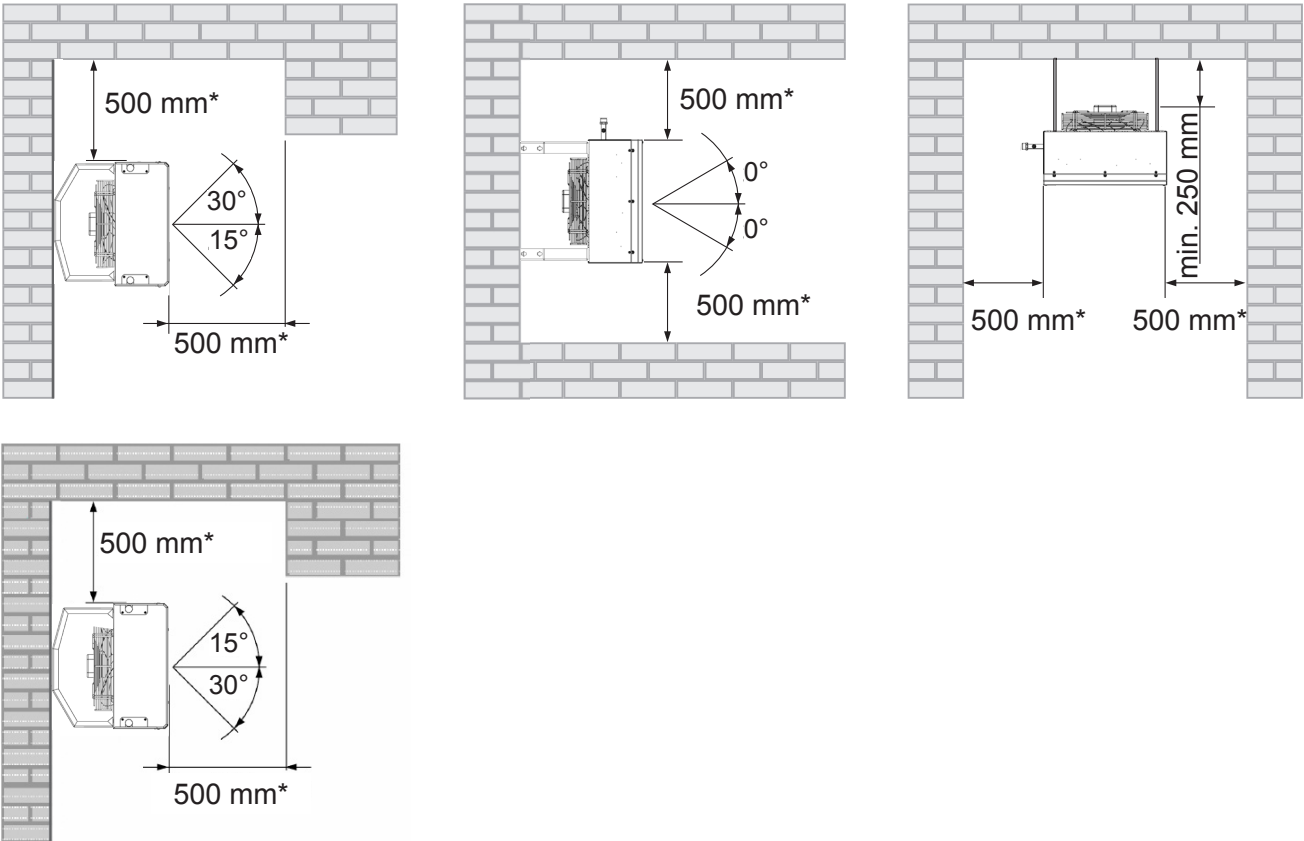

* - Recommended distance for easy access and installation.



- Heater unit may be installed on the wall or ceiling.
- It must be operated in indoor covered and dry premises with the ambient temperature from +5°C to +35°C and relative humidity up to 90%.
- Heater unit is not designed for circulation of air containing flammable or explosive compounds, chemical exhalations, rough dust, soot, grease, toxins, germs, etc.

6. INSTALLATION

INSTALLATION OF COVERS

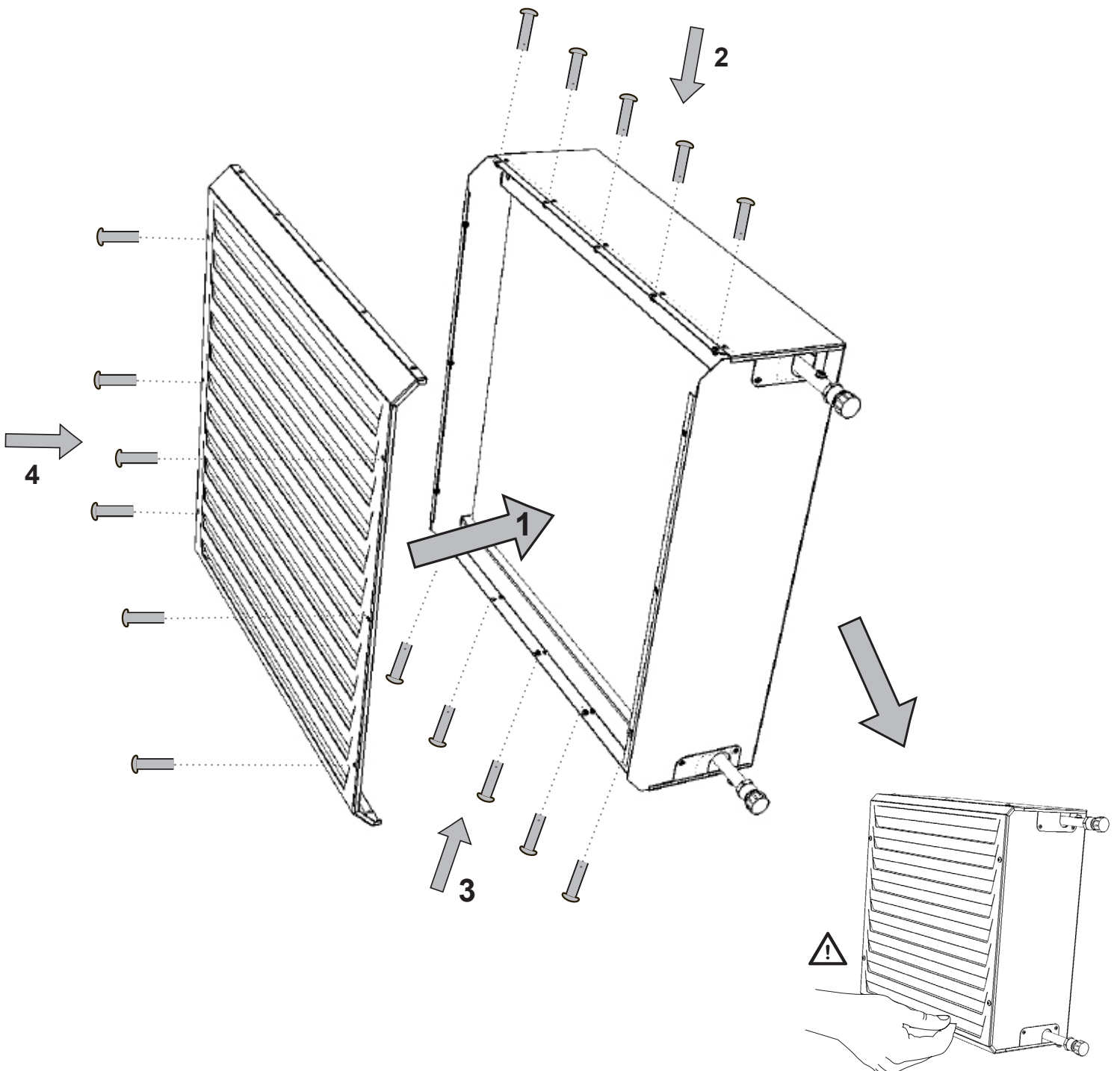
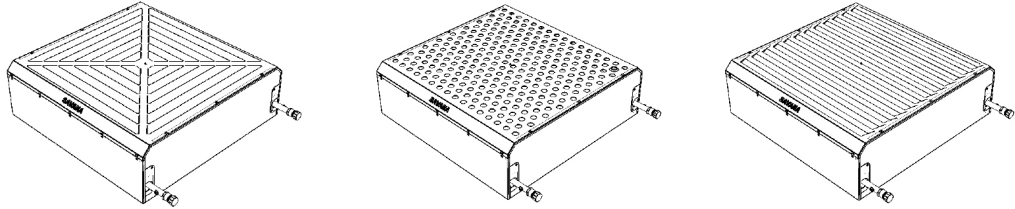

6. INSTALLATION

INSTALLATION OF COVERS

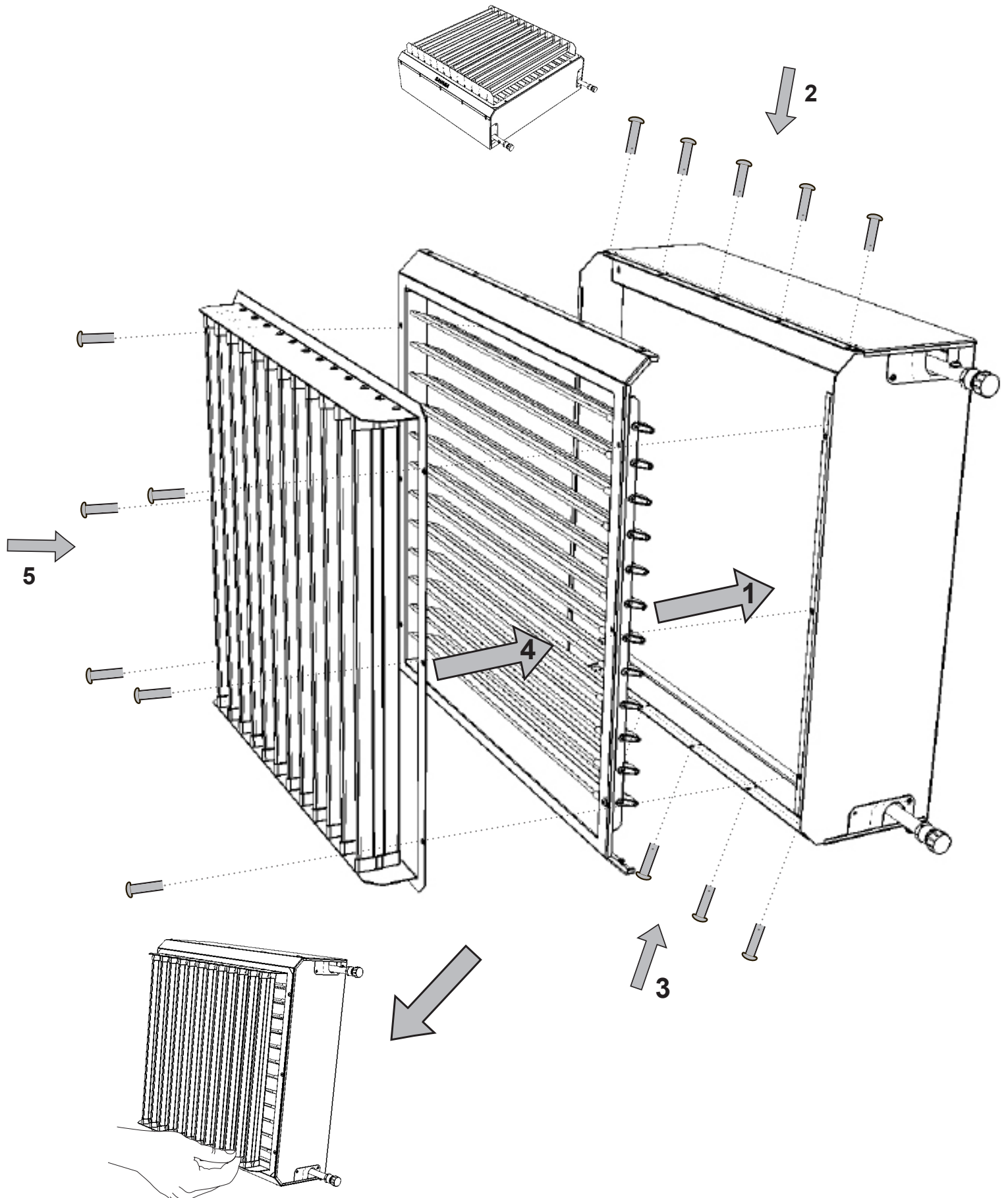

6. INSTALLATION

6.1-2 WALL INSTALLATION

Wall installation of **SAVANA** Heat units is made on brackets. The bracket is an optional accessory of the heater units and must be ordered separately.



For any manipulation with the heater unit, protective gloves must be used to avoid injury.

6.1-2.1 Allocate the wall installation point

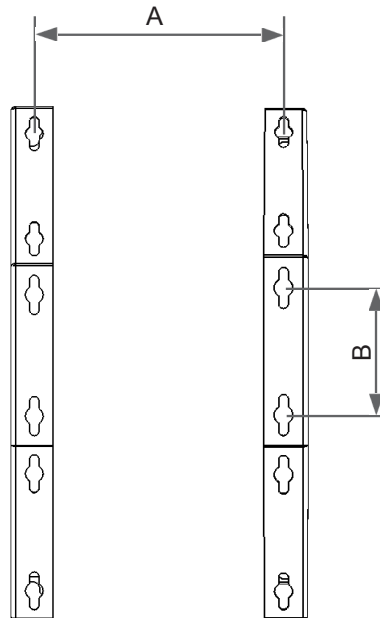

Type	A	B
SAV-1	404	100
SAV-2	504	130
SAV-4	704	200
SAV-6	804	230



Mark wholes for fixing the bracket on the wall. You can verify correct spacing of wholes by attaching the bracket to the point market.

6. INSTALLATION

6.1-2.2 Install the unit on the wall

1) Allocate wholes on the wall and screw in holders

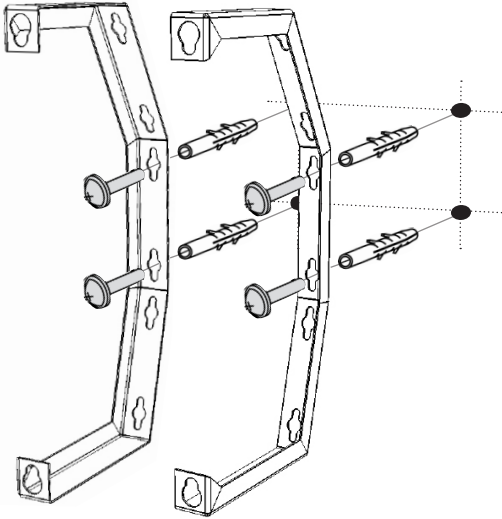

2) Screw in upper screws to the heater and leave space for holder insertion ca 1/3 of the screw length

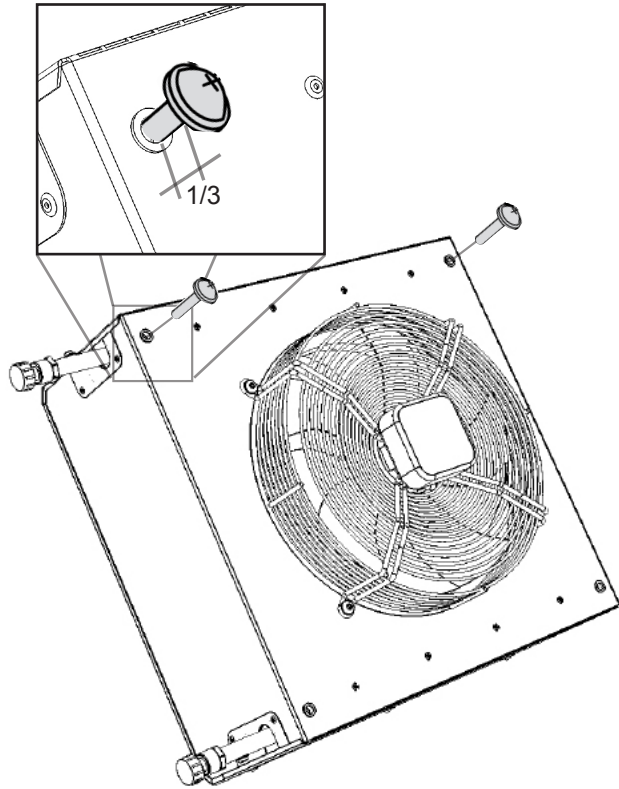

3) Put the unit on holders and screw it in all

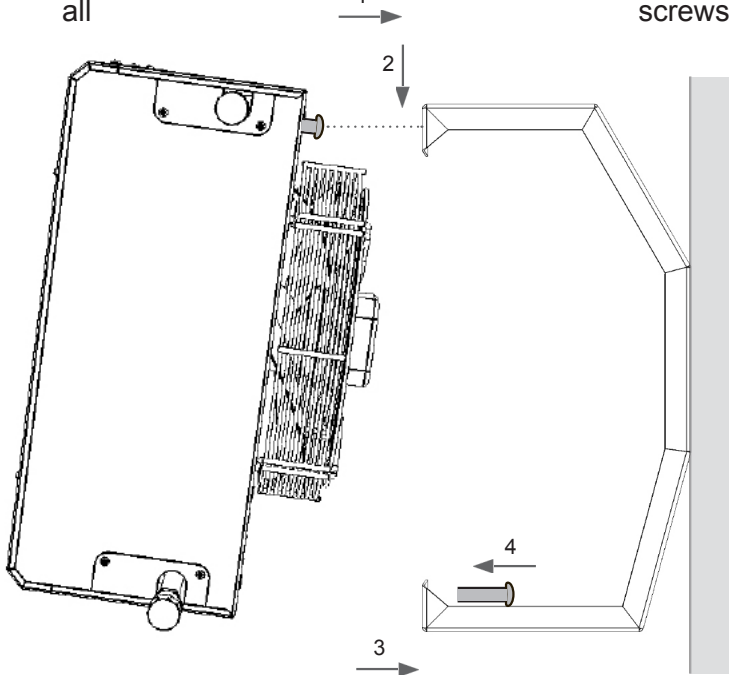

4) Screw lower screws on and check tightness of screws

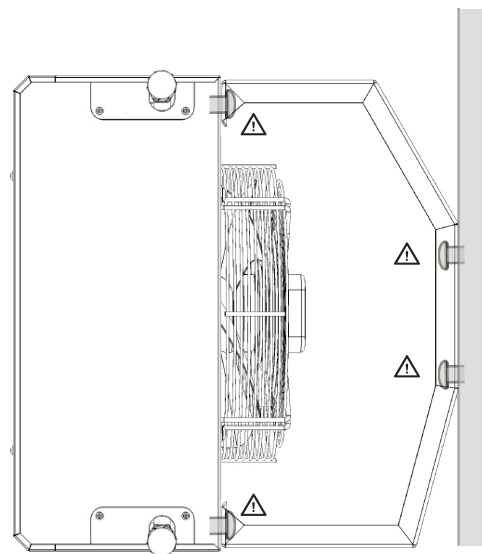

! It must be fixed firmly to the wall!
Use quality connecting material for anchoring!

6. INSTALLATION

6.1-3 CEILING INSTALLATION

Ceiling installation of **SAVANA** Heat units is made on threaded rods M8. Threaded rods are optional accessories and must be ordered separately



For any manipulation with the heater unit, protective gloves must be used to avoid injury by sharp edges.

6.1-3.1 Allocate the ceiling installation point

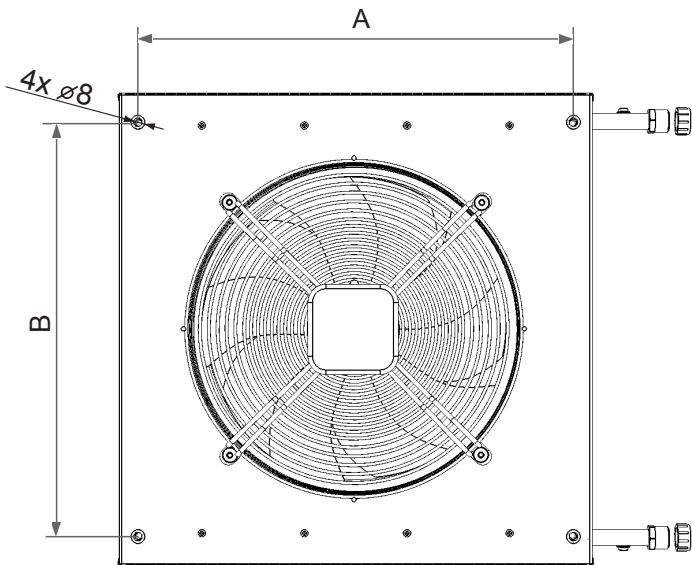

Type	A	B
SAV-1	408	383
SAV-2	508	483
SAV-4	708	683
SAV-6	808	783

Dimensions in the table are in mm

6.1-3.2 Install the unit on the ceiling

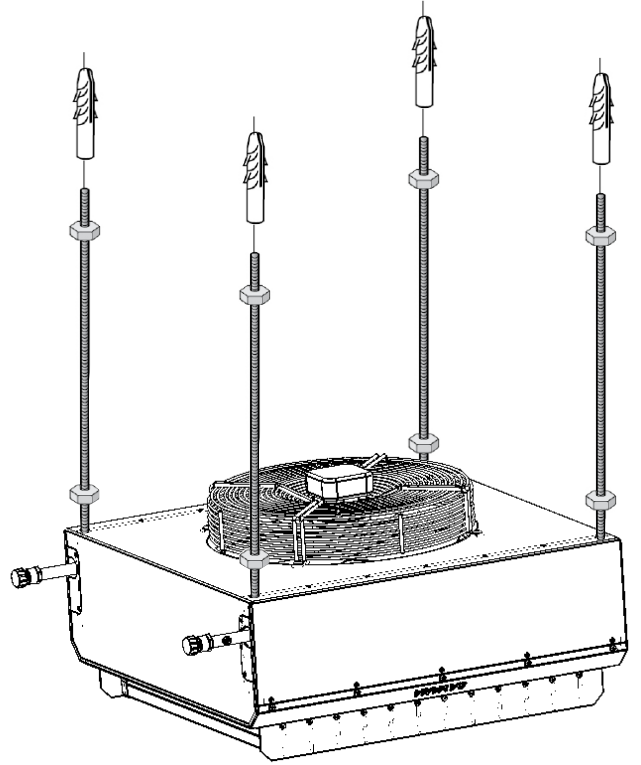

must be fixed firmly to the ceiling! Use quality connecting material for anchoring!

6. INSTALLATION

6.2 WATER EXCHANGER CONNECTION

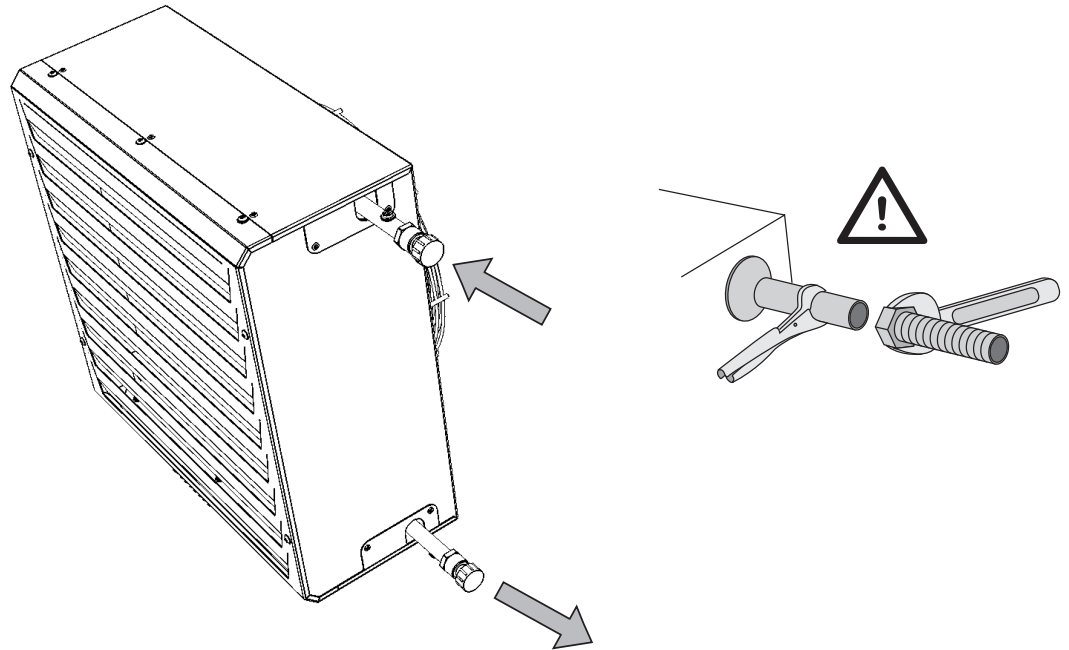

- Flexible hoses with connection; see the table



Type	Water connection
SAV-1-2R	3/4"
SAV-2-2R	3/4"
SAV-4-2R	3/4"
SAV-6-2R	1"

Type	Water connection
SAV-1-3R	1"
SAV-2-3R	1"
SAV-4-3R	1"
SAV-6-3R	1 1/4"

Connection and pressure tests of the heater must be carried out by person with technical knowledge in the area of water installations who is required to follow standards and regulations in force

- Water inlet and outlet positions are marked on the heater unit shell.
- **Maximum water temperature is +110°C. Maximum pressure is 1.6 MPa.**
- We suggest installation of stop valves on water inlets and outlets of the exchanger to be able to shut the water supply off.
- Exchangers dispose of bleeder screws located on both, pipe inlet and outlet.
- At water temperatures over 50C we recommend that the fan runs continuously.

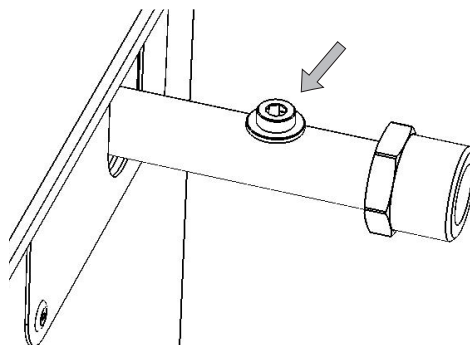

6. INSTALLATION

6.3 CONNECTING ELECTRICAL EQUIPMENT AND ACCESSORIES

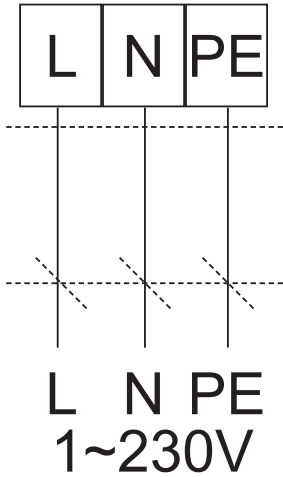

- Main power supply must be off prior to any intervention inside the heater unit!
- Electrical connection must be made based on a project of a qualified project designer of electrical equipment.
- Installation can be carried out by worker with higher specialized education in the electrical field.
- National regulations and directives must be complied with.
- Electrical diagrams on the product have higher priority than diagrams in this manual!
- Prior to installation, check whether indication of terminals corresponds with indication in the electrical diagram. In case of any doubts, please contact your supplier and do not connect the heater unit by any means.
- We recomend maximum 5 EC fans in parallel operation to one 0-10V signal

6.3-1 Supply cable

Connecting terminal board for the connection cable in the fan box.

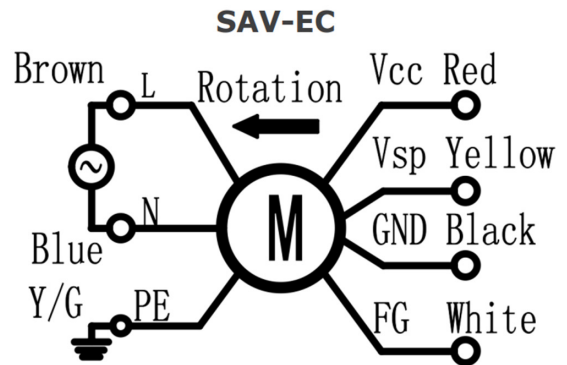
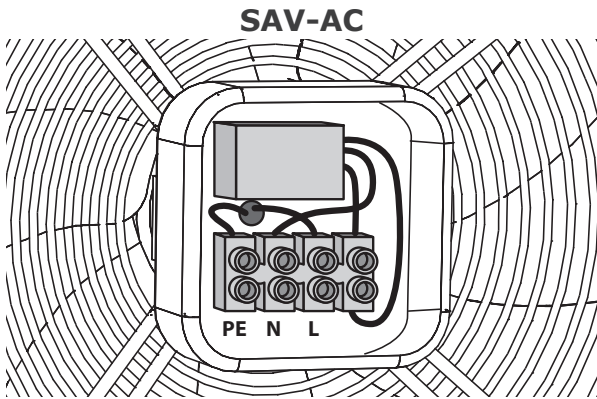

SAV-AC

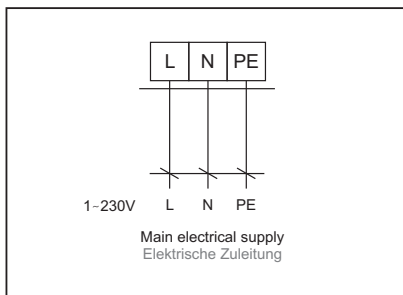

SAV-EC

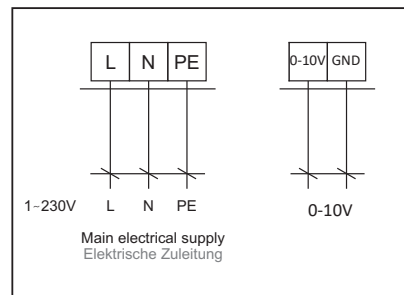

6. INSTALLATION

- Electrical parameters are stated on the model identification plate located on the heater unit shell.

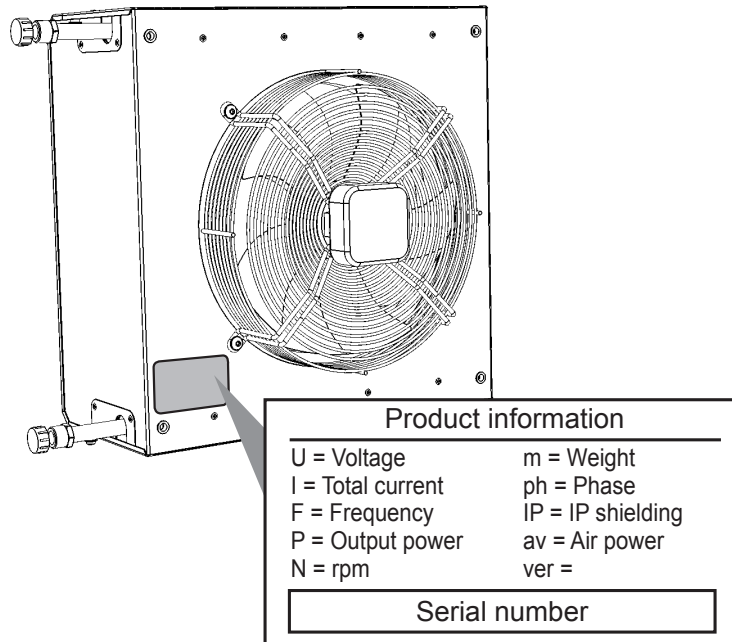

- Heater unit must be connected by TN-S system, which means that the neutral wire must always be connected.
- Main switch disconnecting all mains poles must always be included in the mains supply.
- Electrical shielding of the heater unit is IP44.

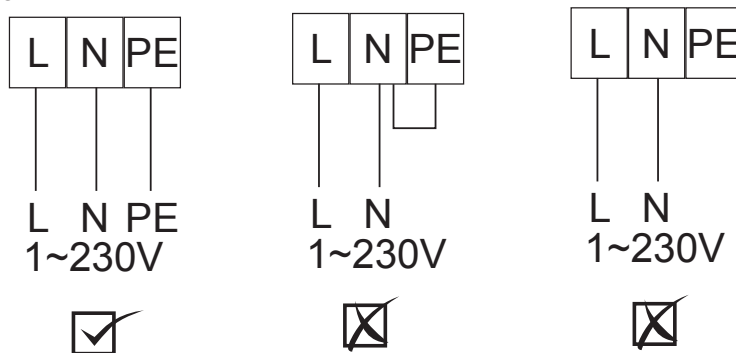

- El. power supply phases to the heater unit must be connected through a protective power circuit breaker of corresponding current and type. Distances between disconnected contacts must be higher than 3 mm.
- The heater unit must be connected so that it is possible to disconnect it from the el. power supply by single component.

Minimum dimensioning of supply cables:

Type	Cable
	[conductor x mm ²]
SAV-1	3 x 1,5
SAV-2	3 x 1,5
SAV-4	3 x 1,5
SAV-6	3 x 1,5

6. INSTALLATION

6.3-2 Electrical accessories

6.3.-2.1 Speed regulation

The supply voltage determining the speed of the fan of the **SAVANA** Heat unit can be regulated. Minimum permitted voltage is **125 V**.



- -to regulate the fan speed of **SAVANA** Heat units, no frequency converter may be used!
- -- In case of ceiling installation, take heat radiation from the water exchanger to the motor into account, and ensure that regulation enables cooling of the water exchanger first followed by motor turn off, when the unit is switched off.
- -Failing that, there is a risk of reduced service life of the motor or its damage. Should this procedure not be observed, a claim regarding possible motor damage will not be admitted.



- -For detail description of fan regulation see manuals of individual regulators.

6.3.-2.2 Water exchanger regulation



If the fan is off, it is recommended to stop the hot water supply to the exchanger. High temperatures inside the unit may reduce the service life of the fan!

Three-way valve with actuator ZV3

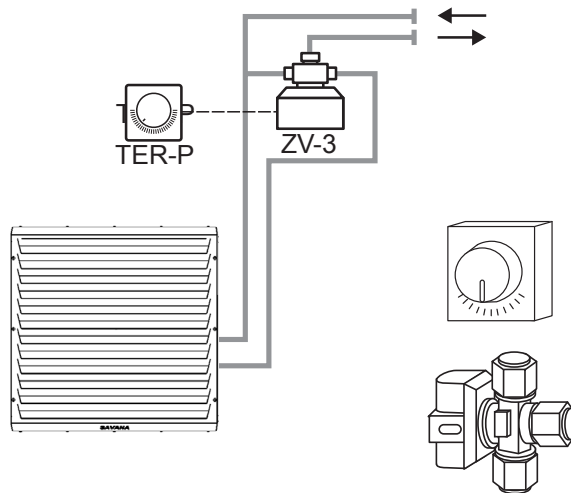

- For detail description of water exchanger regulation see manuals of individual regulating components

7. FIRST START-UP

Check the following before you put the heater unit into operation.

- Whether no tools or other subjects that could damage the unit were left inside the unit.
- Whether the el. power, or heating water, is supplied correctly.
- Whether the heater unit is duly covered.
- Whether the regulation is connected correctly.

7.1 ACTIVATION

Verify basic functions of the device (fan operation, heating) by first activation. Verify other possible settings and functions of the product according to the manual to the regulation used.

7.2 SETTING THE DIRECTION OF EXHAUST AIR (for adjustable laths)

Make the setting by deflection of laths in the direction required.

 **Laths must be always open when the unit is in operation!**

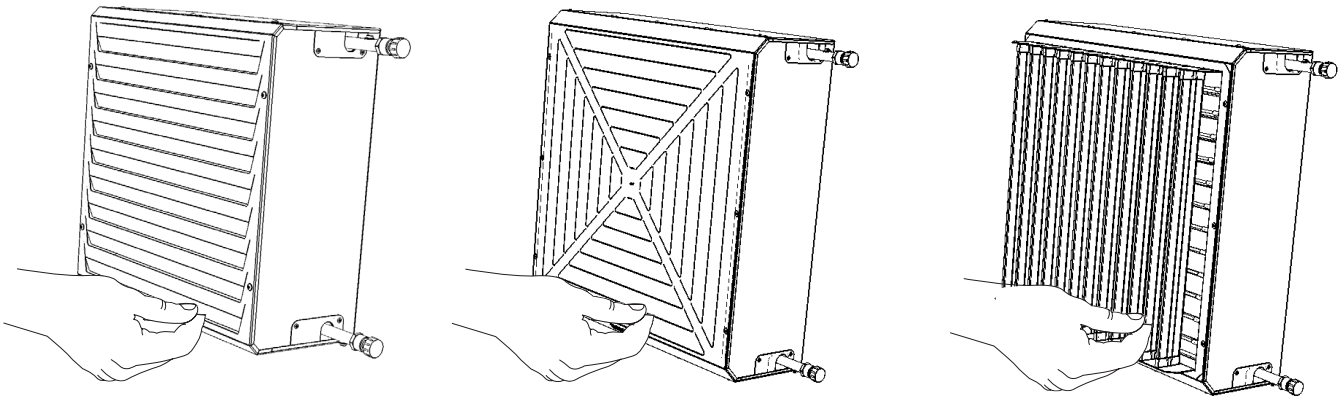

Or set up using the bracket 15° or 30°

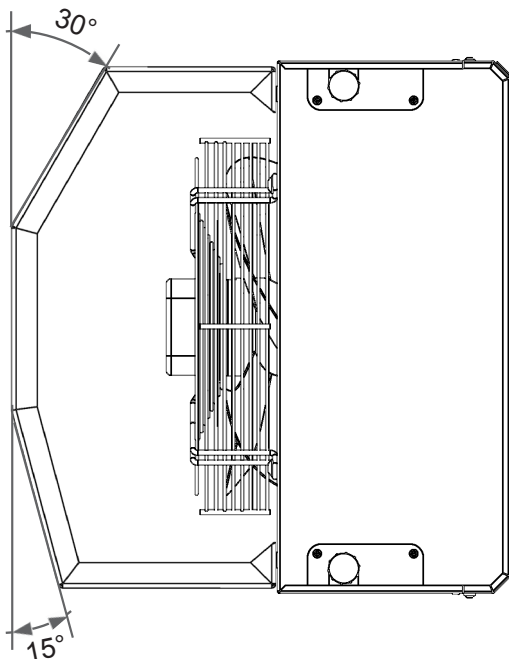

7.3 FILTER INSTALLATION

Dust filters may be added to units.

It is a special filtration medium from synthetic fibres KS 15/60, filtration class G2.

These filters are considered accessories and they are not regularly supplied with the unit.

Unit type	Filter code	Pcs
SAV-1	FI-PYTEL-KRUH-G2-SAV-1	1
SAV-2	FI-PYTEL-KRUH-G2-SAV-2	1
SAV-4	FI-PYTEL-KRUH-G2-SAV-4	1
SAV-6	FI-PYTEL-KRUH-G2-SAV-6	1

FILTER INSTALLATION PROCEDURE

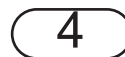
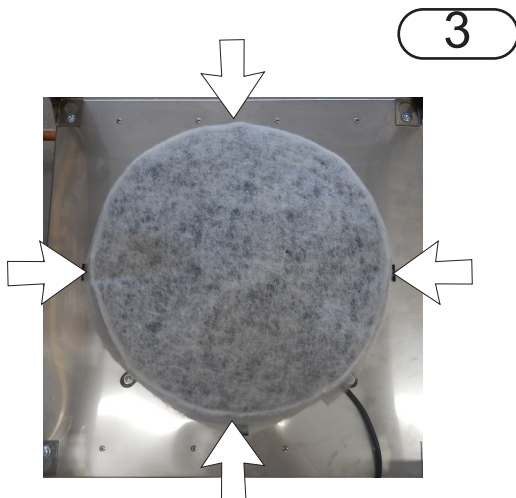
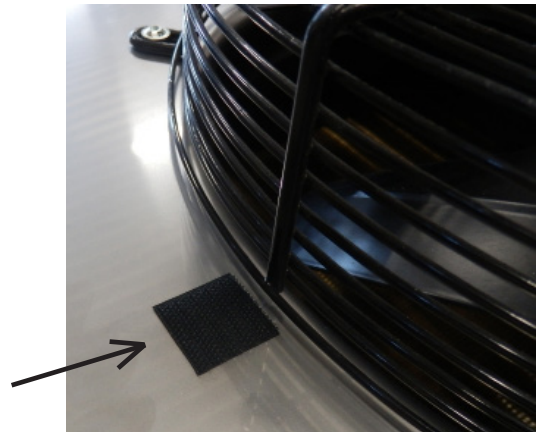
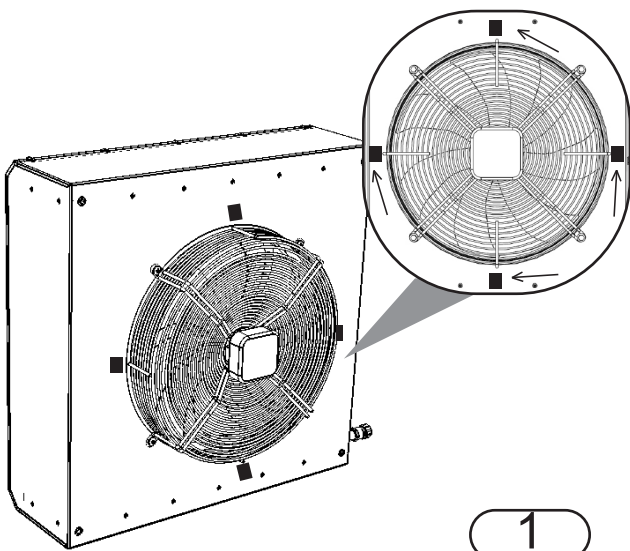

8. MAINTENANCE

8.1 PERIODIC CLEANING OF HEATER UNIT



During maintenance of the heater unit, main el. power supply must be off. It is necessary to let the unit cool down prior to maintenance works!

For any manipulation with the unit, it is necessary to wear protective gloves to avoid injury from sharp edges!



- -spanner, size 10 mm
- -vacuum cleaner
- -hand brush
- -rag
- -non-aggressive cleaning agent (soap water)

It is recommended to carry out periodic checks of unit and filter condition after each 500 hours of operation, and also before and after the heating season.

If the heater unit is not in operation for extended time, we suggest turning the unit on for at least one hour once every six months.

Adapt filter checks to local conditions.

8. MAINTENANCE

8.1-1 Cleaning procedure

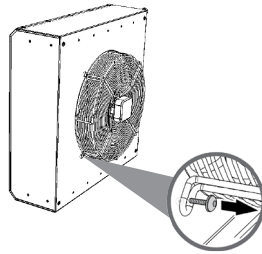

1) Dismantle the fan from the unit shell

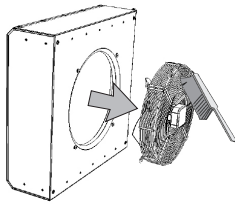

2) Clean the fan

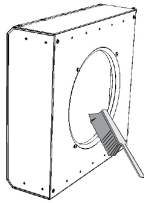

3) Clean the water exchanger and inside of the heater unit

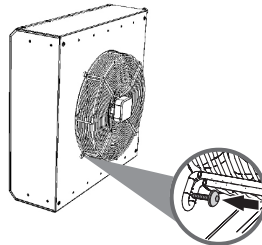

4) Mount the fan back on



- It is prohibited to use compressed air, chemicals, solvents, water or sharp subject for cleaning.
- Clean the water exchanger and inside of the heater unit using a fine hand brush or vacuum cleaner.
- Preferably use a rag and soap water for cleaning of the unit shell.

8.2 PERIODIC CHECKS OF HEATER UNITS

It is recommended to carry out periodic checks of the unit after each 500 hours of operation, and also before and after the heating season.

- water exchanger contamination check
- fan condition check (in particular fan and bearings function)
- check of water exchanger tightness and connection
- unit check for possible damage (in particular fan basket)
- check of bolt connection tightening, in particular for the bracket
- filter check

9. TROUBLESHOOTING

During maintenance of the heater unit, the main power supply must be off. It is necessary to let the unit cool down before maintenance works!

For any manipulation with the heater unit, protective gloves must be used to avoid injury from sharp edges!

If you are not sure by correctness of your steps, do not start any repairs and call the professional service!!!

Possible problems ...

Device behaviour	Anticipated problem	Solution
The device is noisy	Air in the device.	De-aerate the device by increased pressure and flow of the heating medium.
	Stop valves on the device are not fully open.	Open fully the stop valves.
	Damaged fan bearings. Impeller shows clearance or cannot rotate freely.	It is necessary to dismantle the fan and replace bearings in an authorised service, or replace the complete fan.
	Unbalanced impeller of the fan rotates freely, but vibrates shortly when the fan is turned on.	Dismantle the fan and give it to a professional service for balancing.
Insufficient heat capacity of the heater unit	The exchanger is blocked.	Dismantle the fan and clean the exchanger. Use preferably hot water or steam for cleaning. Do not use aggressive detergents.
	Stop or regulation valves on the device are not fully open.	Open fully the stop valves, and check whether the regulation valve is open.
	Incorrect rotation direction of the mixing valve.	Correct el. connections on the terminal board of the regulation.
	Clogged filter.	Replace or clean the filter thoroughly.
The fan is not working	No power supply or control voltage	Check the main power supply or control signal
	Motor is over heated. Check temperature and check if fan is possible to rotate.	Integrated thermal protection disconnected the motor. Try function after motor will cool down - needed POWER ON reset

If you cannot find, remove the defect or if it requires intervention to the device, please call an authorised service!

10. SERVICE

10.1 IF YOU CANNOT CLEAR THE FAULT BY YOURSELF

If you cannot solve the problem, please call the supplier.

Provide following information to get a prompt solution:

- product type
- serial number
- operation time
- accessories used
- installation place
- installation conditions (incl. electrical)
- detail description of the fault and steps made to its removal

Warranty and after-warranty service is provided by the manufacturer, supplier or authorised service organisation. When ordering a service intervention, it is necessary to provide fault specification, unit type on the label, and place of installation.

10.2 PRODUCT DISCHARGE FROM OPERATION – DISPOSAL

Before you discard the product, make it unusable. Even old products contain raw materials that can be reused. Dispose them in the collection point for processed raw materials.

It is better to let the product discard in a place specialised for such purpose, it will also be possible to reuse recyclable materials. Dispose unusable parts of the product in a controlled dumping site.



When disposing materials, it is necessary to comply with respective national regulations for waste disposal

11. ACCESSORIES

Various accessories may be purchased to the heater unit SAVANA. For detail information see technical sheet of the product.

CONTACT:

2VV, s.r.o.,
Fáblovka 568,
533 52 Pardubice,
Czech Republic

Website:

<http://www.2vv.cz/>

