

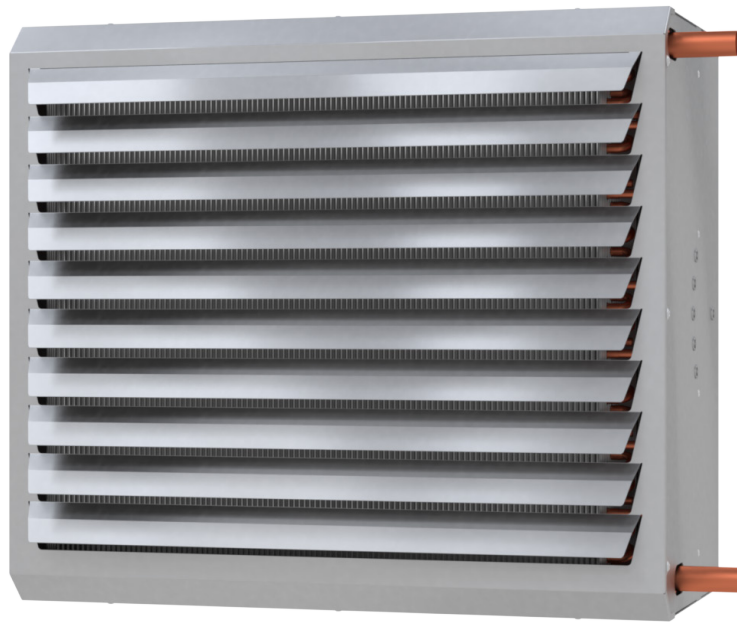

PARTNER
IN VENTILATION
2VV.CZ

EN

SAVANA 3 INOX



INSTALLATION AND OPERATION

CE



MEANING OF SYMBOLS IN THE MANUAL



WARNING!



READ CAREFULLY!



TECHNICAL INFORMATION



CHECK THE SUPPLY

CHECK THAT THE PRODUCT DELIVERED CORRESPONDS TO YOUR ORDER.

UNPACK AND CHECK THE SHIPMENT.

AFTER UNWRAPPING, CHECK THE STATE OF THE UNIT AND ALL THE COMPONENTS.

NEVER USE A UNIT THAT IS DAMAGED.

IF THE UNIT IS NOT IMMEDIATELY UNWRAPPED AFTER RECEIPT, IT SHOULD BE STORED IN DRY INDOOR PREMISES AT A TEMPERATURE OF +5 °C TO +40 °C.

DO NOT LET CHILDREN PLAY WITH THE UNIT.

CHECK THE SUPPLY

- AFTER THE DELIVERY, CHECK IMMEDIATELY POSSIBLE DAMAGE OF THE PACKED PRODUCT. IN CASE OF DAMAGED PACKAGING, CONTACT YOUR FORWARDING COMPANY. SHOULD THE CLAIM NOT BE FILED ON TIME, NO CLAIMS MAY BE LODGED IN THE FUTURE.
- CHECK WHETHER THE PRODUCT TYPEE CORRESPONDS WITH THE ORDER. IN CASE OF NON-COMPLIANCE, DO NOT UNPACK THE UNIT AND REPORT THE FAULT TO THE SUPPLIER IMMEDIATELY.
- AFTER UNPACKING, PLEASE CHECK THE CONDITION OF THE HEATER UNIT AND OTHER ACCESSORIES. IN CASE OF DOUBT, CONTACT YOUR SUPPLIER.
- NEVER INSTALL DAMAGED HEATER UNIT!
- IF YOU DO NOT UNPACK THE HEATER UNIT IMMEDIATELY AFTER ITS DELIVERY, IT MUST BE STORED IN A DRY INDOOR ENVIRONMENT WITH THE AMBIENT TEMPERATURE FROM **+5°C TO +35°C**.

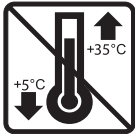

	<p>All used packaging materials are environment-friendly and may be reused or recycled. Contribute actively to the environmental protection and be particular in correct disposal and reuse or packaging materials.</p>	
--	---	--

UNPACK THE UNIT

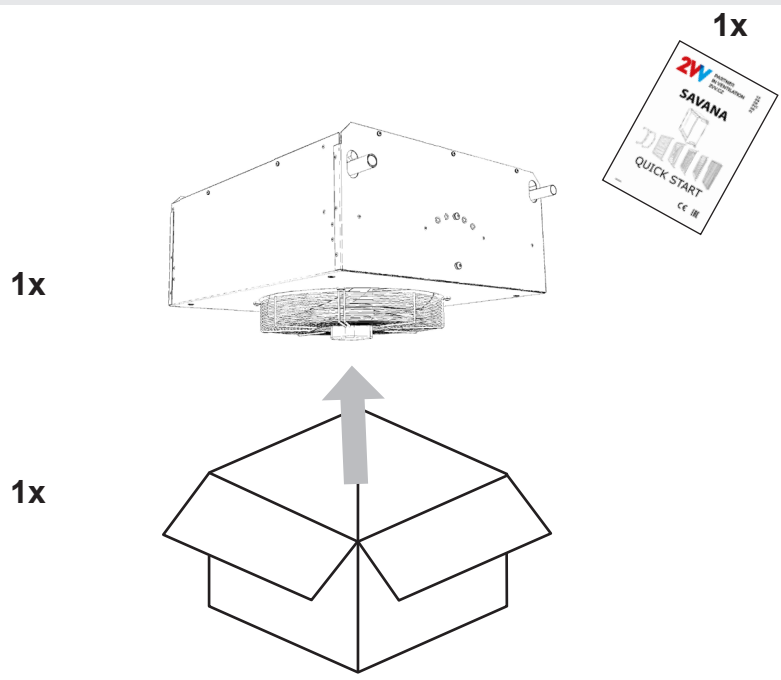

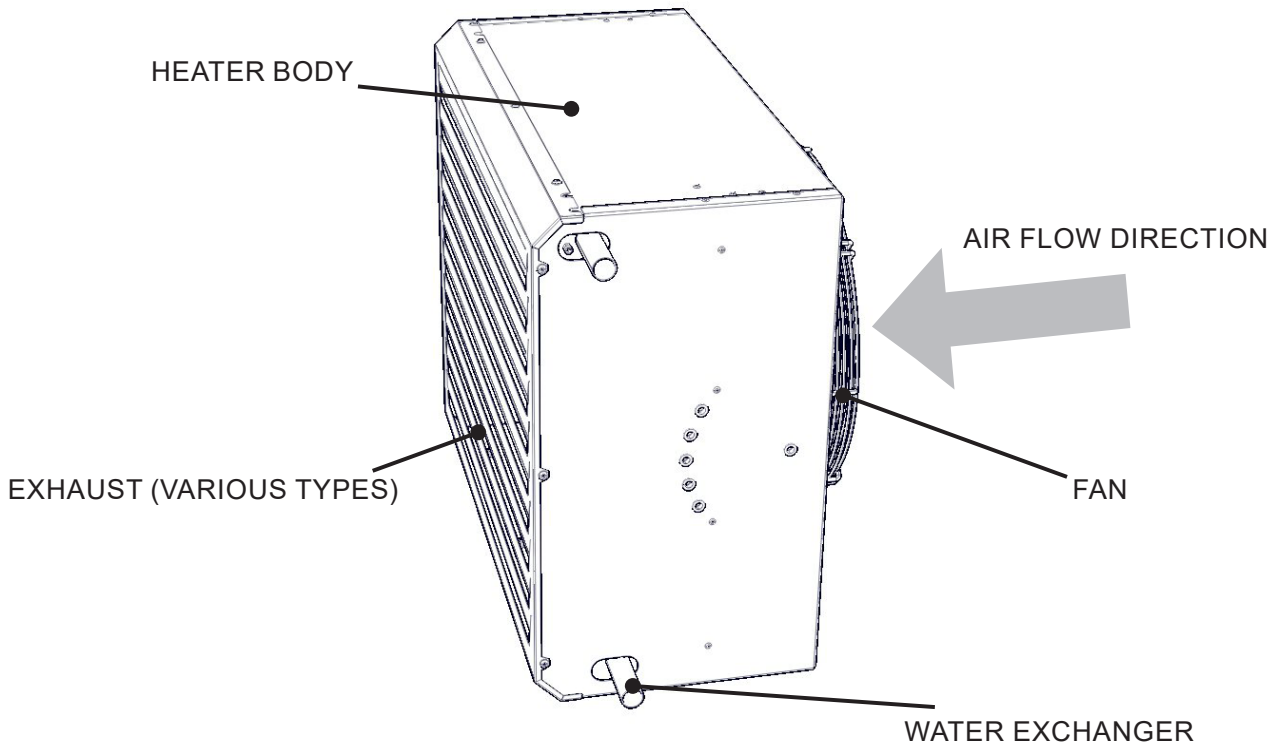

TECHNICAL INFORMATION

TYPE	AIR OUTPUT	VOLTAGE	CURRENT	POWER INPUT	WEIGHT*
	[m ³ /h]	[V/Hz]	[A]	[W]	[kg]
OHSA3-200-2R	2600	230/50-60	1,50	180	22
OHSA3-400-2R	4700	230/50-60	1,40	320	35
OHSA3-600-2R	7000	230/50-60	2,60	630	46

HOT-WATER EXCHANGER MADE FROM CU/AL IS DESIGNED FOR MAX. OPERATING TEMPERATURE OF WATER +110°C AND MAX. OPERATING PRESSURE 1.6 MPA.

* WEIGHT OF THE HEATER UNIT WITHOUT WATER IN THE WATER COIL.

DIMENSIONS

OHSA3-200

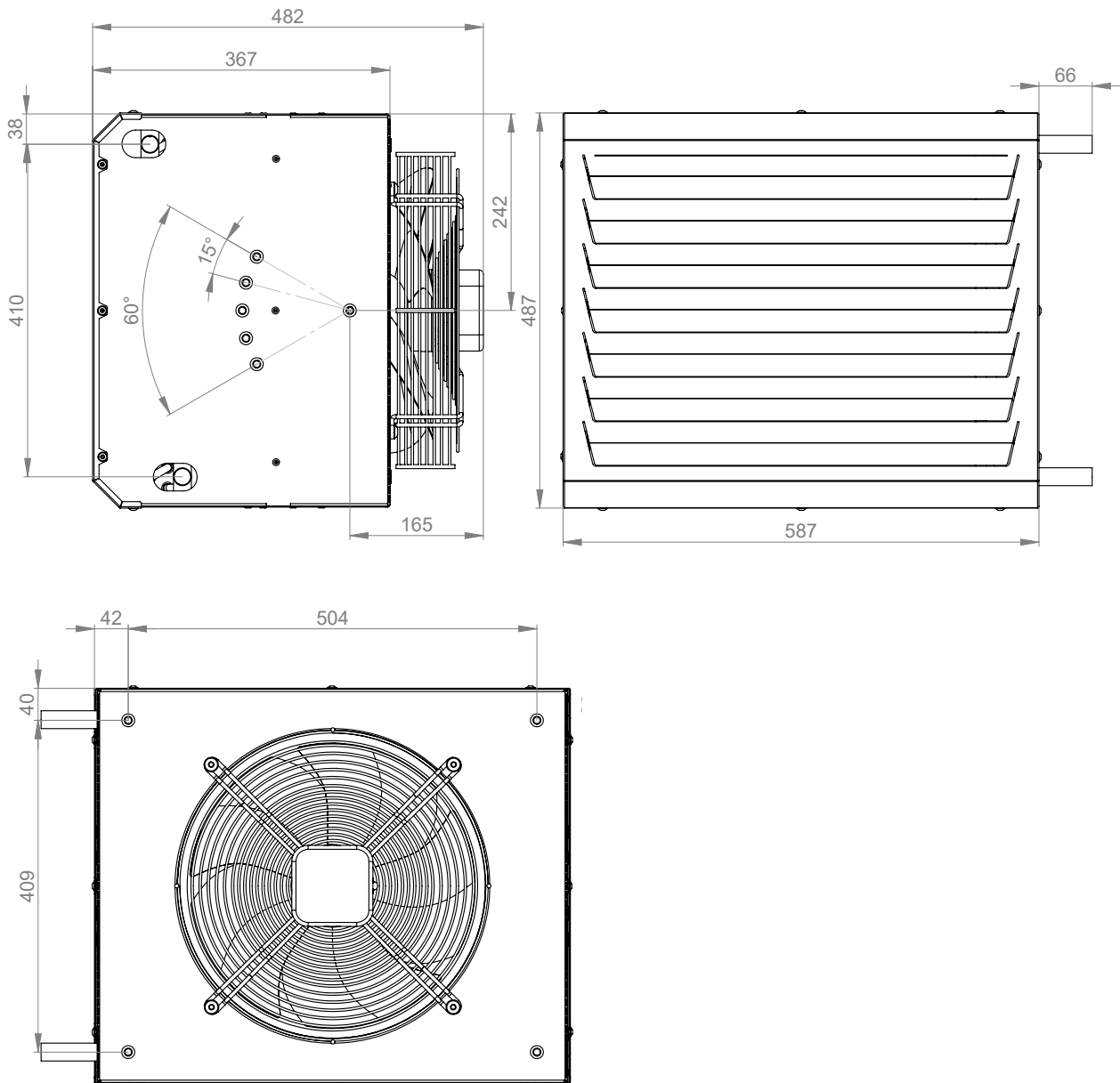

DIMENSIONS

OHSA3-400

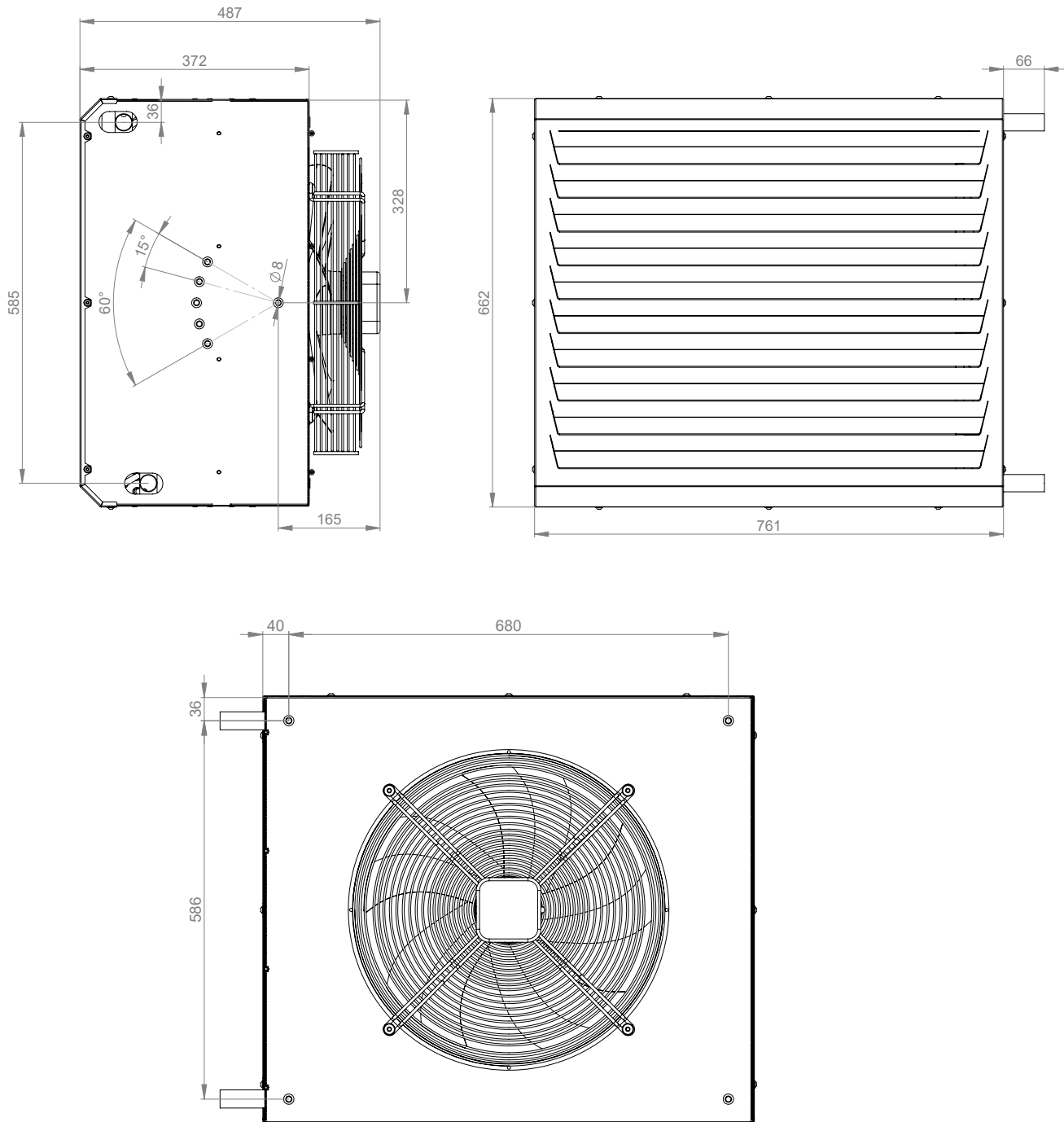

OHSA3-600

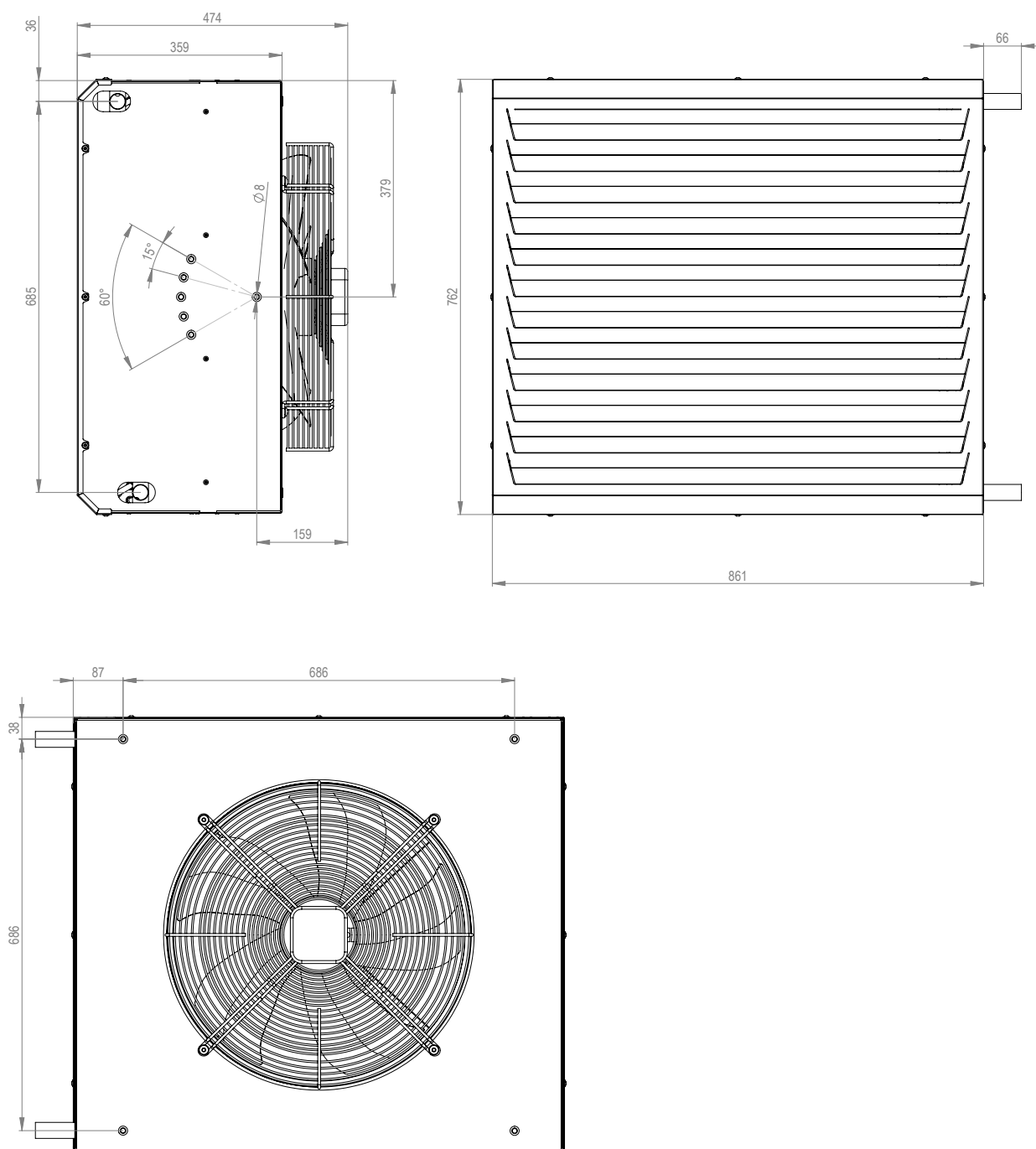



SELECT INSTALLATION POINT

RECOMMENDED INSTALLATION DISTANCES

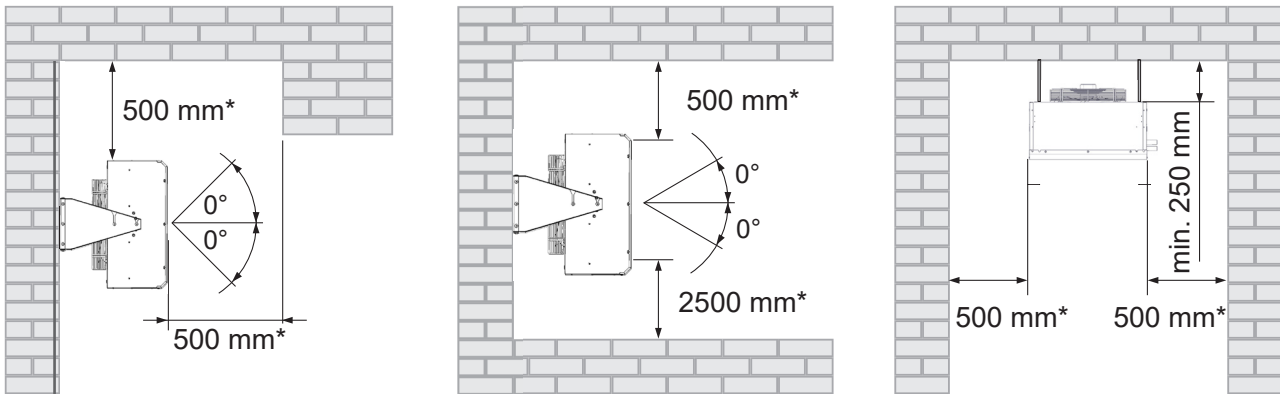

- * - RECOMMENDED DISTANCE FOR EASY ACCESS AND INSTALLATION.
- * - THE INSTALLATION DISTANCE FROM THE FLOOR MUST BE AT LEAST 2500 MM.



READ CAREFULLY

- THE HEATER UNIT MAY BE INSTALLED ON THE WALL OR CEILING.
- IT MUST BE OPERATED IN INDOOR COVERED AND DRY PREMISES WITH THE AMBIENT TEMPERATURE FROM +5°C TO +35°C AND RELATIVE HUMIDITY UP TO 90%.
- HEATER UNIT IS NOT DESIGNED FOR CIRCULATION OF AIR CONTAINING FLAMMABLE OR EXPLOSIVE COMPOUNDS, CHEMICAL EXHALATIONS, ROUGH DUST, SOOT, GREASE, TOXINS, GERMS, ETC.
- THE HEATER UNIT UNIT CAN BE INSTALLED IN ANY POSITION/ORIENTATION

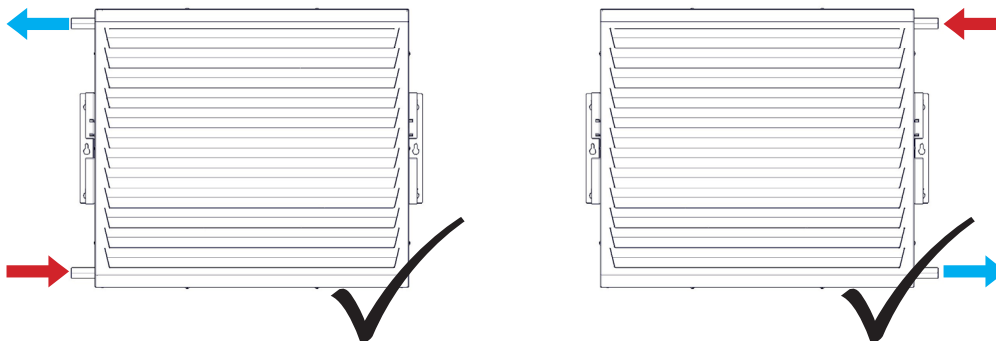

INSTALLATION OF COVERS

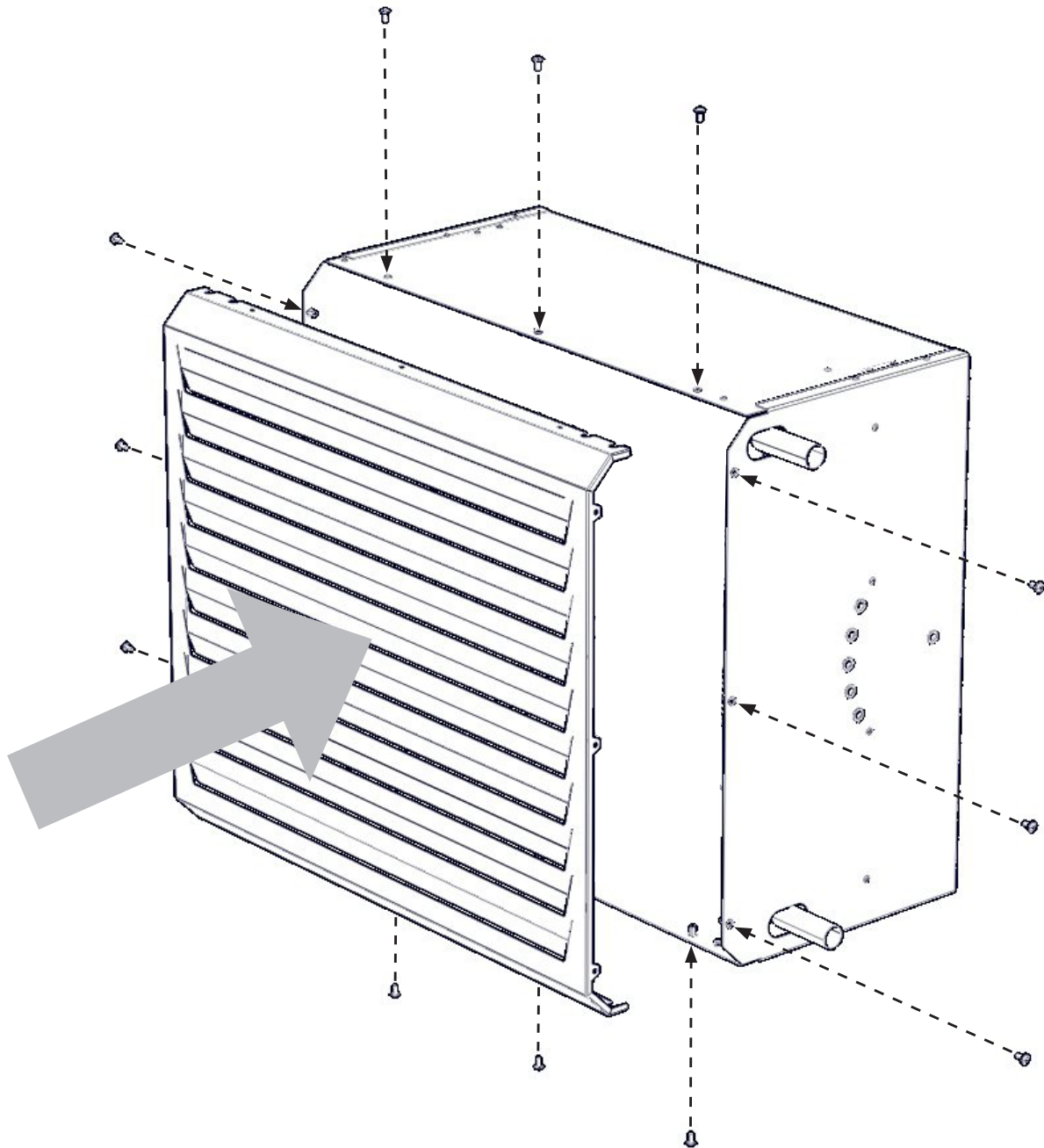

WALL INSTALLATION

WALL INSTALLATION OF **SAVANA** HEAT UNITS IS MADE ON BRACKETS. THE BRACKET IS AN OPTIONAL ACCESSORY OF THE HEATER UNITS AND MUST BE ORDERED SEPARATELY.



READ CAREFULLY

FOR ANY MANIPULATION WITH THE HEATER UNIT, PROTECTIVE GLOVES MUST BE USED TO AVOID INJURY.

ALLOCATE THE WALL INSTALLATION POINT

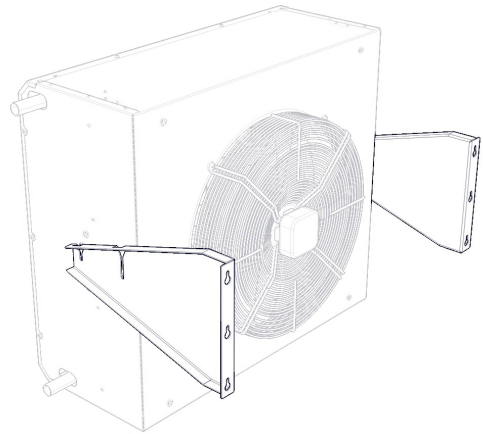
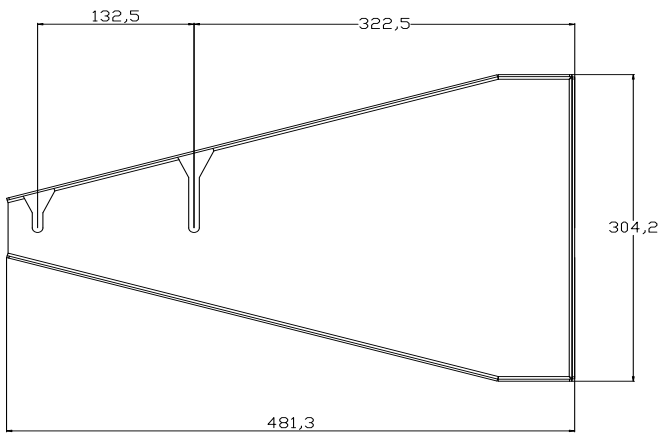

TEMPLATE FOR POSITIONING SAVANA WALL-MOUNTING BRACKET

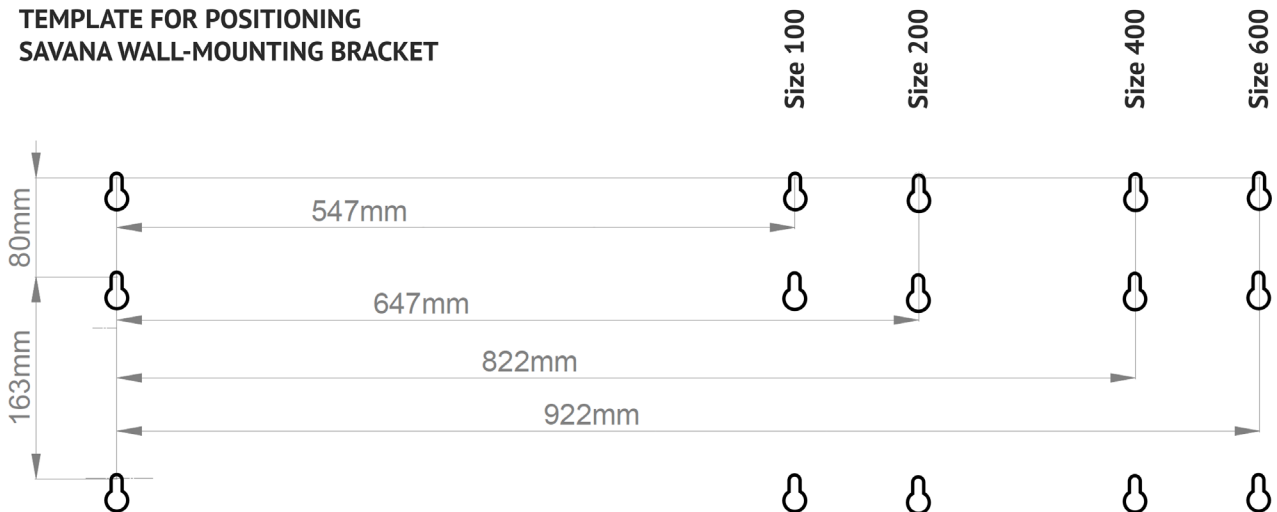

TECHNICAL INFORMATION

MARK HOLES FOR FIXING THE BRACKET ON THE WALL. YOU CAN VERIFY CORRECT SPACING OF HOLES BY ATTACHING THE BRACKET TO THE POINT MARKER.

WALL INSTALATION

1) ALLOCATE HOLES ON THE WALL AND MOUNT IN HOLDERS

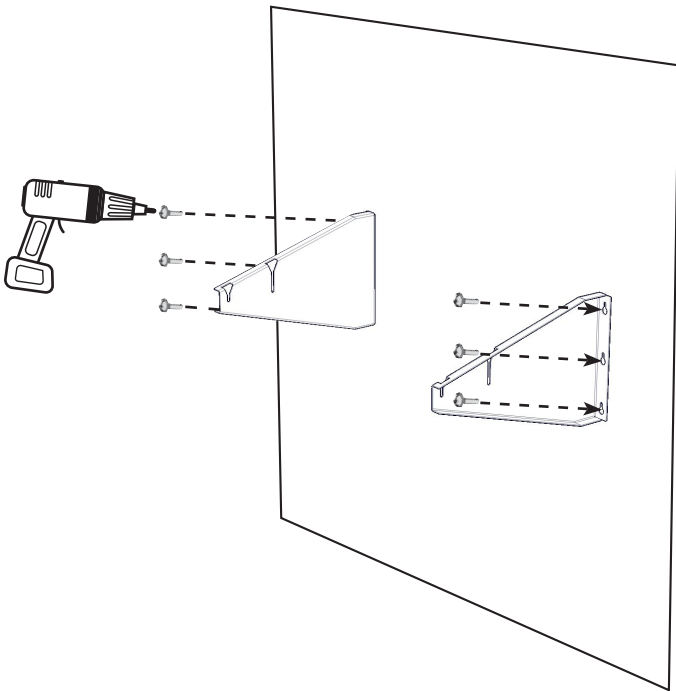

2) SCREW IN SCREWS TO THE HEATER AND LEAVE SPACE FOR HOLDER INSERTION CA 1/3 OF THE SCREW LENGTH

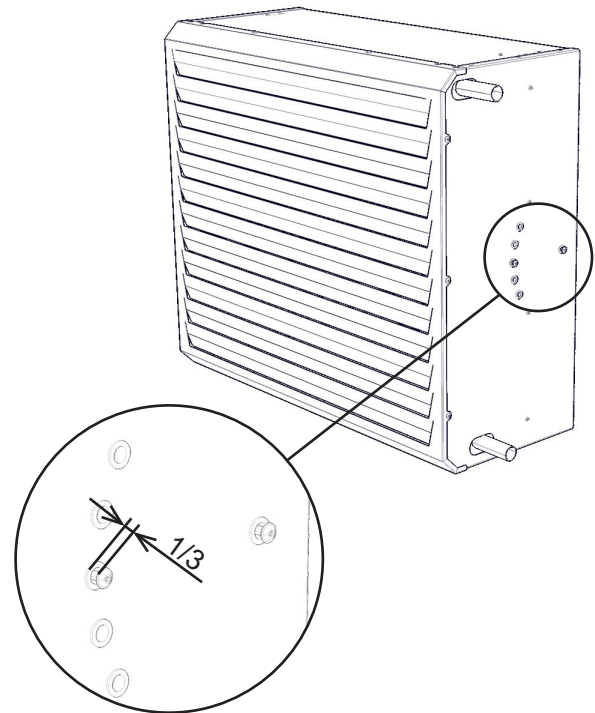

THE UNIT MUST BE FIXED FIRMLY TO THE WALL! USE QUALITY CONNECTING MATERIAL FOR ANCHORING!

3) PUT THE UNIT ON HOLDERS FROM ABOVE

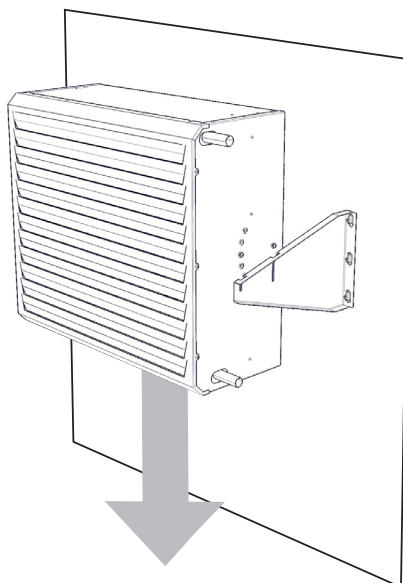

4) TIGHTEN THE SCREWS TO FIX THE UNIT POSITION

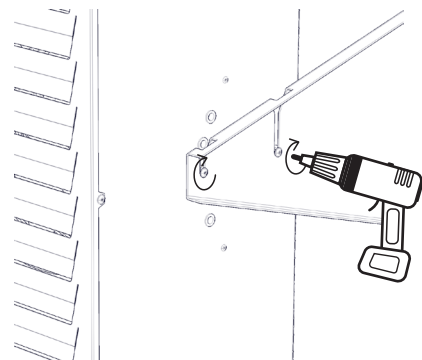



CEILING INSTALLATION

CEILING INSTALLATION OF **SAVANA** HEAT UNITS IS MADE ON THREADED RODS M8. THREADED RODS ARE OPTIONAL ACCESSORIES AND MUST BE ORDERED SEPARATELY



READ CAREFULLY

FOR ANY MANIPULATION WITH THE HEATER UNIT, PROTECTIVE GLOVES MUST BE USED TO AVOID INJURY BY SHARP EDGES.

ALLOCATE THE CEILING INSTALLATION POINT

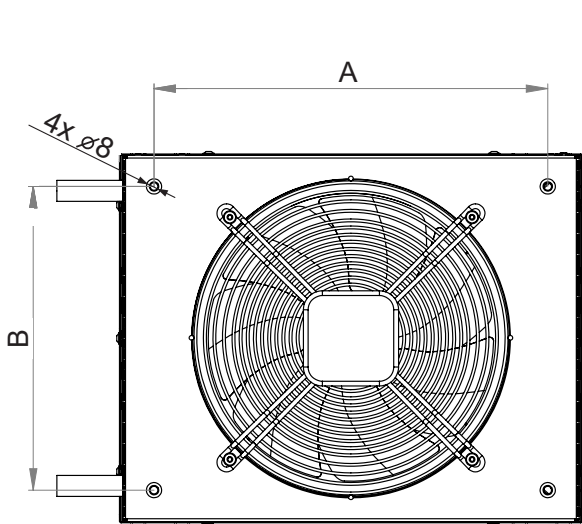

Typ	A	B
OHSA3-200	504	409
OHSA3-400	679	584
OHSA3-600	686	686

Dimensions in the table are in mm

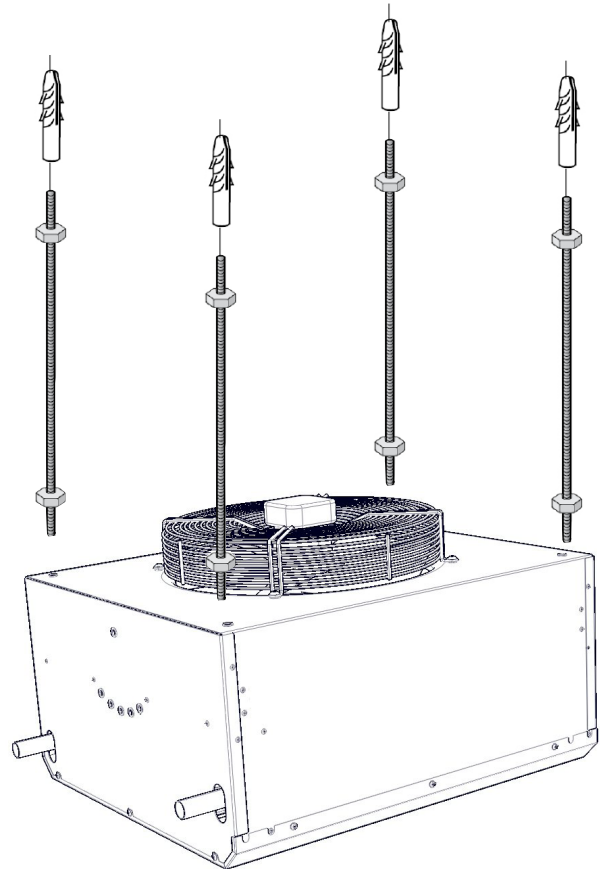

WATER EXCHANGER CONNECTION

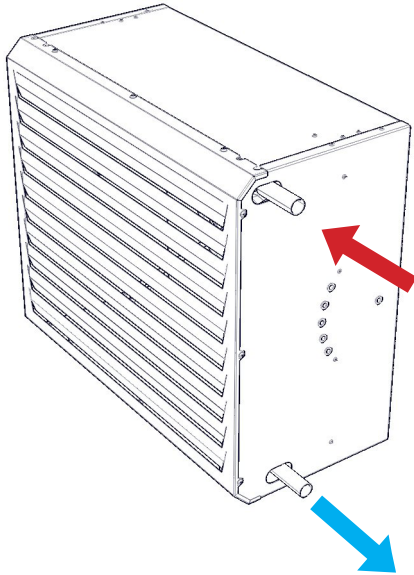

OHSA3-200-2R	22 mm
OHSA3-400-2R	28 mm
OHSA3-600-2R	28 mm

CONNECTING

CONNECTION AND PRESSURE TESTS OF THE HEATER MUST BE CARRIED OUT BY PERSON WITH TECHNICAL KNOWLEDGE IN THE AREA OF WATER INSTALLATIONS WHO IS REQUIRED TO FOLLOW STANDARDS AND REGULATIONS IN FORCE

- WATER INLET AND OUTLET POSITIONS ARE MARKED ON THE HEATER UNIT SHELL.
- **MAXIMUM WATER TEMPERATURE IS +110°C. MAXIMUM PRESSURE IS 1.6 MPA.**
- WE SUGGEST INSTALLATION OF STOP VALVES ON WATER INLETS AND OUTLETS OF THE EXCHANGER TO BE ABLE TO SHUT THE WATER SUPPLY OFF.
- EXCHANGERS DO NOT DISPOSE BLEEDER SCREWS LOCATED ON BOTH, PIPE INLET AND OUTLET.
- WE RECOMMEND THAT THE FAN RUNS CONTINUOUSLY AT WATER TEMPERATURES OVER 50°C.

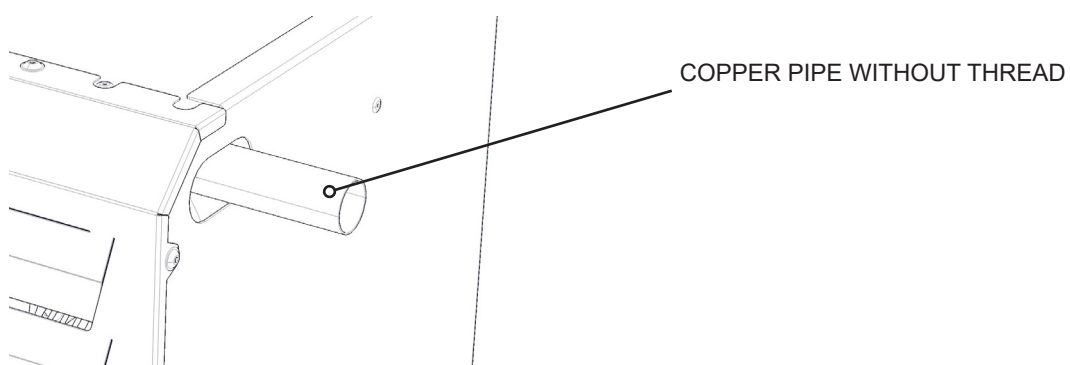



CONNECTING ELECTRICAL EQUIPMENT AND ACCESSORIES

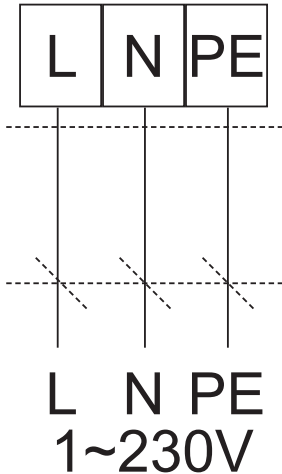

- MAIN POWER SUPPLY MUST BE OFF PRIOR TO ANY INTERVENTION INSIDE THE HEATER UNIT!
- ELECTRICAL CONNECTION MUST BE MADE BASED ON A PROJECT OF A QUALIFIED PROJECT DESIGNER OF ELECTRICAL EQUIPMENT.
- INSTALLATION CAN BE CARRIED OUT BY WORKER WITH HIGHER SPECIALIZED EDUCATION IN THE ELECTRICAL FIELD.
- NATIONAL REGULATIONS AND DIRECTIVES MUST BE COMPLIED WITH.
- ELECTRICAL DIAGRAMS ON THE PRODUCT HAVE HIGHER PRIORITY THAN DIAGRAMS IN THIS MANUAL!
- PRIOR TO INSTALLATION, CHECK WHETHER INDICATION OF TERMINALS CORRESPONDS WITH INDICATION IN THE ELECTRICAL DIAGRAM. IN CASE OF ANY DOUBTS, PLEASE CONTACT YOUR SUPPLIER AND DO NOT CONNECT THE HEATER UNIT BY ANY MEANS.
- WE RECOMEND MAXIMUM 5 EC FANS IN PARALLEL OPERATION TO ONE 0-10V SIGNAL



POWER SUPPLY CABLE

CONNECTING TERMINAL BOARD FOR THE CONNECTION CABLE IN THE FAN BOX.

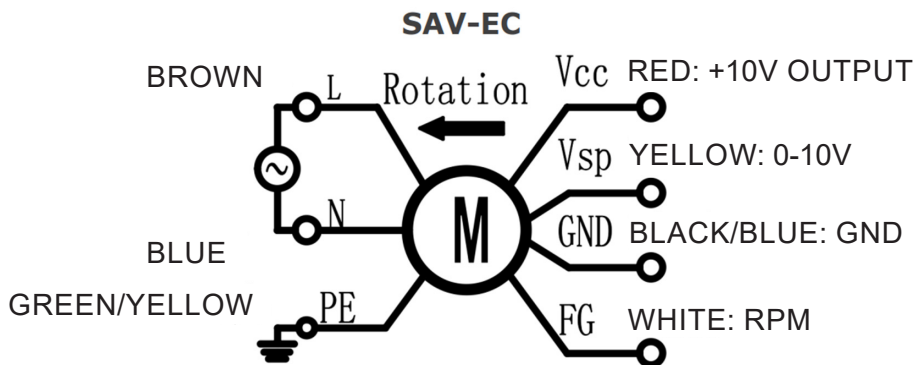

ELECTRICAL PARAMETERS ARE STATED ON THE MODEL IDENTIFICATION PLATE LOCATED ON THE HEATER UNIT BODY

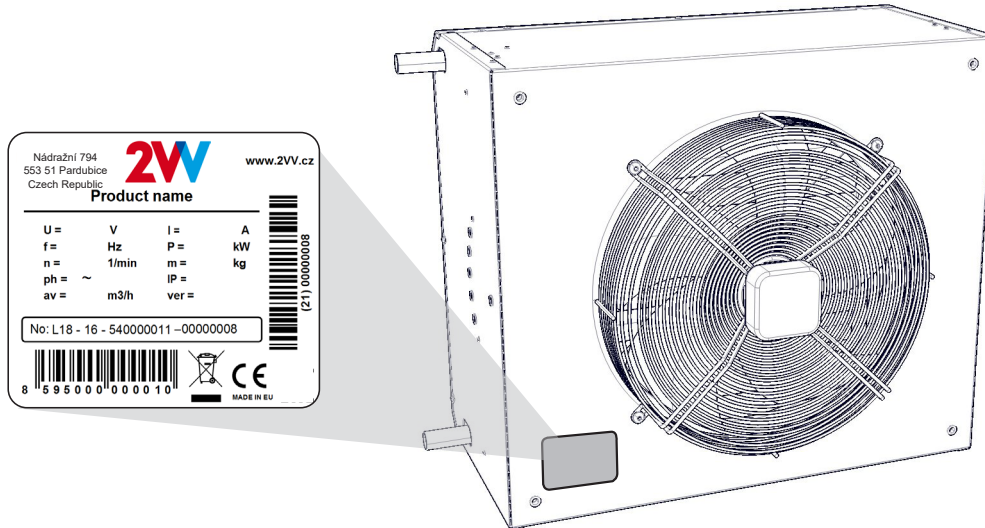

HEATER UNIT MUST BE CONNECTED BY TN-S SYSTEM, WHICH MEANS THAT THE NEUTRAL WIRE MUST ALWAYS BE CONNECTED.
 MAIN SWITCH DISCONNECTING ALL MAINS POLES MUST ALWAYS BE INCLUDED IN THE MAINS SUPPLY.
 ELECTRICAL SHIELDING OF THE HEATER UNIT IS IP44.

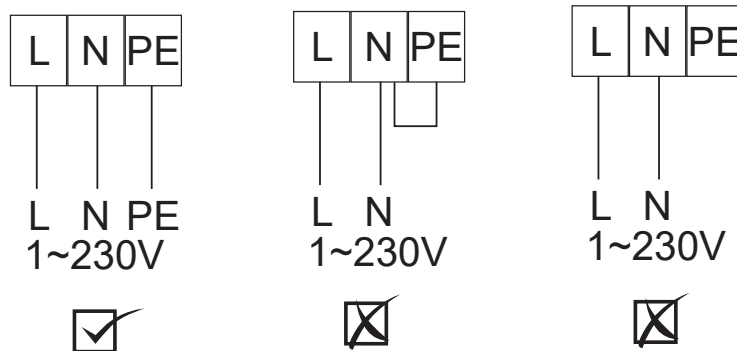

EL. POWER SUPPLY PHASES TO THE HEATER UNIT MUST BE CONNECTED THROUGH A PROTECTIVE POWER CIRCUIT BREAKER OF CORRESPONDING CURRENT AND TYPE. DISTANCES BETWEEN DISCONNECTED CONTACTS MUST BE HIGHER THAN 3 MM.
 THE HEATER UNIT MUST BE CONNECTED SO THAT IT IS POSSIBLE TO DISCONNECT IT FROM THE EL. POWER SUPPLY BY SINGLE COMPONENT.

ELECTRICAL ACCESSORIES

SPEED REGULATION

THE CONTROL VOLTAGE DETERMINING THE SPEED OF THE FAN OF THE **SAVANA** UNIT CAN BE REGULATED IN RANGE 0-10V.

- TO REGULATE THE FAN SPEED OF **SAVANA** HEAT UNITS, NO FREQUENCY CONVERTER MAY BE USED!
- IN CASE OF CEILING INSTALLATION, TAKE HEAT RADIATION FROM THE WATER EXCHANGER TO THE MOTOR INTO ACCOUNT, AND ENSURE THAT REGULATION ENABLES COOLING OF THE WATER EXCHANGER FIRST FOLLOWED BY MOTOR TURN OFF, WHEN THE UNIT IS SWITCHED OFF.
- FAILING THAT, THERE IS A RISK OF REDUCED SERVICE LIFE OF THE MOTOR OR ITS DAMAGE. SHOULD THIS PROCEDURE NOT BE OBSERVED, A CLAIM REGARDING POSSIBLE MOTOR DAMAGE WILL NOT BE ADMITTED.

SPEED REGULATION

- FOR DETAIL DESCRIPTION OF FAN REGULATION SEE MANUALS OF INDIVIDUAL REGULATORS.

WATER EXCHANGER REGULATION

IF THE FAN IS OFF, IT IS RECOMMENDED TO STOP THE HOT WATER SUPPLY TO THE EXCHANGER. HIGH TEMPERATURES INSIDE THE UNIT MAY REDUCE THE SERVICE LIFE OF THE FAN!

THREE-WAY VALVE WITH ACTUATOR ZV3

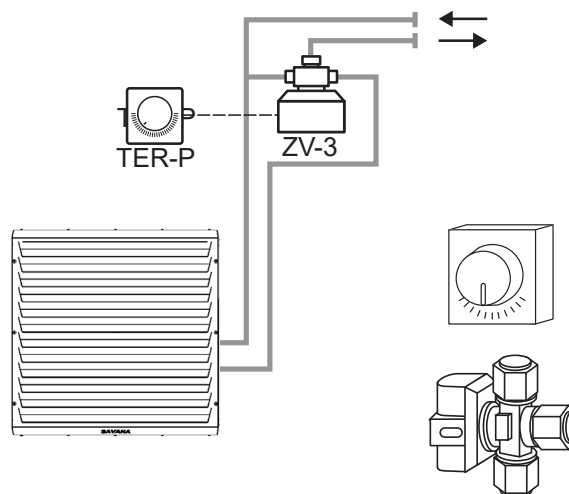

FOR DETAILED DESCRIPTION OF WATER EXCHANGER REGULATION SEE MANUALS OF INDIVIDUAL REGULATING COMPONENTS

ACTIVATION

CHECK THE FOLLOWING BEFORE YOU PUT THE HEATER UNIT INTO OPERATION.

- WHETHER NO TOOLS OR OTHER SUBJECTS THAT COULD DAMAGE THE UNIT WERE LEFT INSIDE THE UNIT.
- WHETHER THE EL. POWER, OR HEATING WATER, IS SUPPLIED CORRECTLY.
- WHETHER THE HEATER UNIT IS DULY COVERED.
- WHETHER THE REGULATION IS CONNECTED CORRECTLY.

VERIFY BASIC FUNCTIONS OF THE DEVICE (FAN OPERATION, HEATING) BY FIRST ACTIVATION. VERIFY OTHER POSSIBLE SETTINGS AND FUNCTIONS OF THE PRODUCT ACCORDING TO THE MANUAL TO THE REGULATION USED.

SETTING THE DIRECTION OF EXHAUST AIR

MAKE THE SETTING BY DEFLECTION OF LATHS IN THE DIRECTION REQUIRED.



LATHS MUST BE ALWAYS OPEN WHEN THE UNIT IS IN OPERATION!

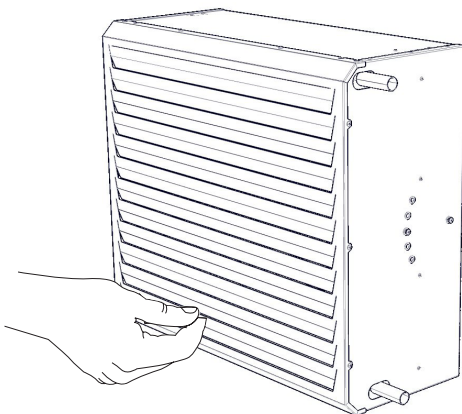

OR SET UP USING THE BRACKET 15° OR 30°

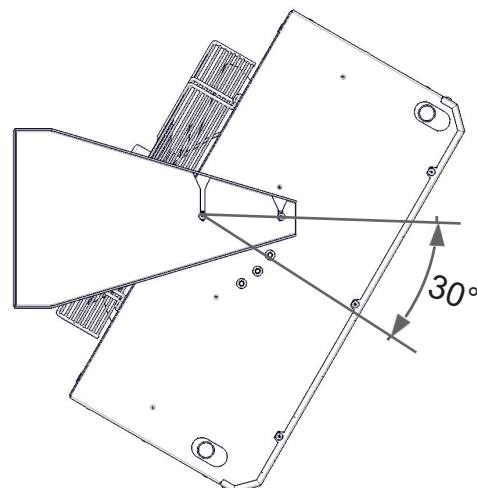
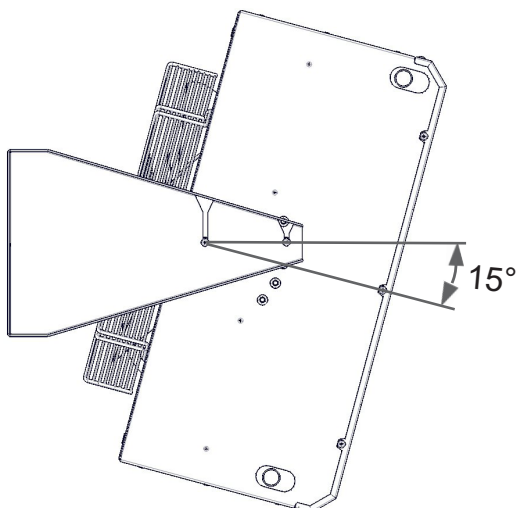



FILTER INSTALLATION PROCEDURE

Unit type	Filter code	Pcs
OHSA3-200	FI-PYTEL-KRUH-G2-SAV-2	1
OHSA3-400	FI-PYTEL-KRUH-G2-SAV-4	1
OHSA3-200	FI-PYTEL-KRUH-G2-SAV-6	1

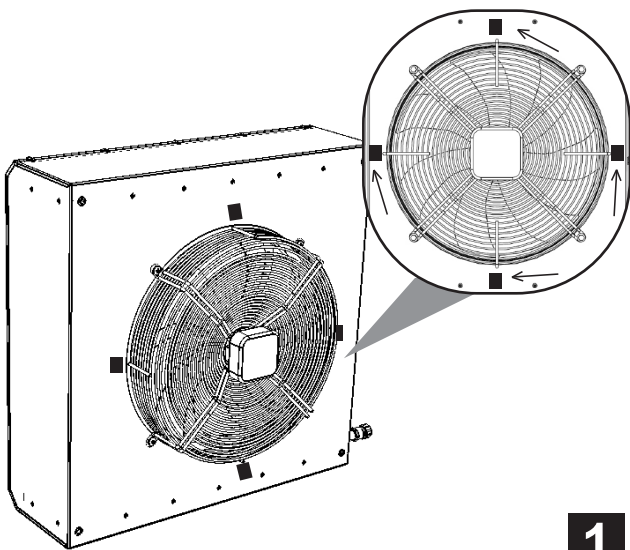

1

2

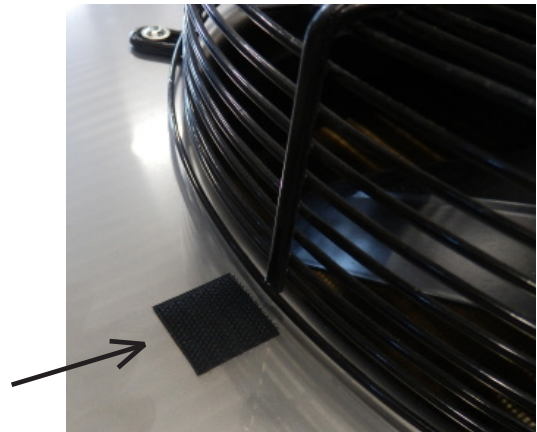

3

4

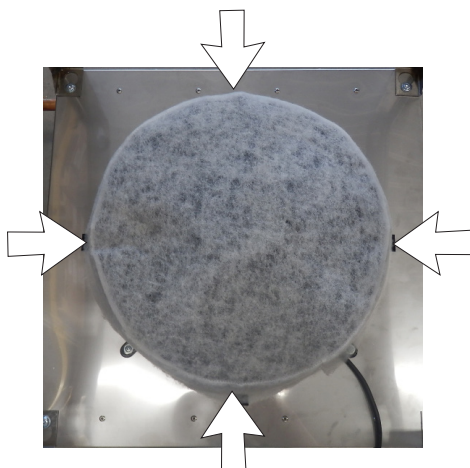



PERIODIC CLEANING OF HEATER UNIT

DURING MAINTENANCE OF THE HEATER UNIT, MAIN EL. POWER SUPPLY MUST BE OFF. IT IS NECESSARY TO LET THE UNIT COOL DOWN PRIOR TO MAINTENANCE WORKS!
FOR ANY MANIPULATION WITH THE UNIT, IT IS NECESSARY TO WEAR PROTECTIVE GLOVES TO AVOID INJURY FROM SHARP EDGES!



TOOLS NEEDED

- -SPANNER, SIZE 10 MM
- -VACUUM CLEANER
- -HAND BRUSH
- -RAG
- -NON-AGGRESSIVE CLEANING AGENT (SOAP WATER)

IT IS RECOMMENDED TO CARRY OUT PERIODIC CHECKS OF UNIT AND FILTER CONDITION AFTER EACH 500 HOURS OF OPERATION, AND ALSO BEFORE AND AFTER THE HEATING SEASON.
IF THE HEATER UNIT IS NOT IN OPERATION FOR EXTENDED TIME, WE SUGGEST TURNING THE UNIT ON FOR AT LEAST ONE HOUR ONCE EVERY SIX MONTHS.
ADAPT FILTER CHECKS TO LOCAL CONDITIONS.

CLEANING PROCEDURE

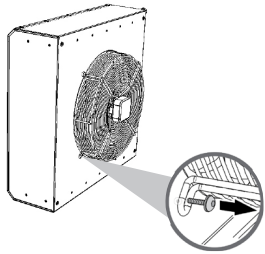

1) DISMANTLE THE FAN FROM THE UNIT SHELL

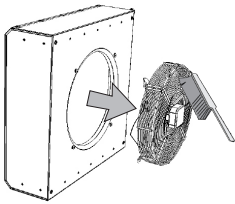

2) CLEAN THE FAN

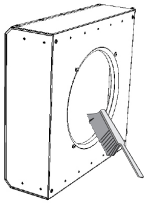

3) CLEAN THE WATER EXCHANGER AND INSIDE OF THE HEATER UNIT

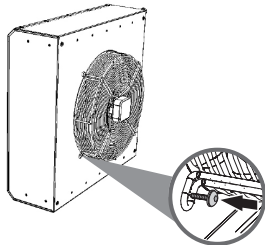

4) MOUNT THE FAN BACK ON

- IT IS PROHIBITED TO USE COMPRESSED AIR, CHEMICALS, SOLVENTS, WATER OR SHARP SUBJECT FOR CLEANING.
- CLEAN THE WATER EXCHANGER AND INSIDE OF THE HEATER UNIT USING A FINE HAND BRUSH OR VACUUM CLEANER.
- PREFERABLY USE A RAG AND SOAP WATER FOR CLEANING OF THE UNIT SHELL.

PERIODIC CHECKS OF HEATER UNITS

IT IS RECOMMENDED TO CARRY OUT PERIODIC CHECKS OF THE UNIT AFTER EACH 500 HOURS OF OPERATION, AND ALSO BEFORE AND AFTER THE HEATING SEASON.

- WATER EXCHANGER CONTAMINATION CHECK
- FAN CONDITION CHECK (IN PARTICULAR FAN AND BEARINGS FUNCTION)
- CHECK OF WATER EXCHANGER TIGHTNESS AND CONNECTION
- UNIT CHECK FOR POSSIBLE DAMAGE (IN PARTICULAR FAN BASKET)
- CHECK OF BOLT CONNECTION TIGHTENING, IN PARTICULAR FOR THE BRACKET
- FILTER CHECK

DURING MAINTENANCE OF THE HEATER UNIT, THE MAIN POWER SUPPLY MUST BE OFF. IT IS NECESSARY TO LET THE UNIT COOL DOWN BEFORE MAINTENANCE WORKS!

FOR ANY MANIPULATION WITH THE HEATER UNIT, PROTECTIVE GLOVES MUST BE USED TO AVOID INJURY FROM SHARP EDGES!

IF YOU ARE NOT SURE BY CORRECTNESS OF YOUR STEPS, DO NOT START ANY REPAIRS AND CALL THE PROFESSIONAL SERVICE!!!

POSSIBLE ISSUES ...

DEVICE BEHAVIOUR	ANTICIPATED PROBLEM	SOLUTION
THE DEVICE IS NOISY	AIR IN THE DEVICE.	DE-AERATE THE DEVICE BY INCREASED PRESSURE AND FLOW OF THE HEATING MEDIUM.
	STOP VALVES ON THE DEVICE ARE NOT FULLY OPEN.	OPEN FULLY THE STOP VALVES.
	DAMAGED FAN BEARINGS. IMPELLER SHOWS CLEARANCE OR CANNOT ROTATE FREELY.	IT IS NECESSARY TO DISMANTLE THE FAN AND REPLACE BEARINGS IN AN AUTHORISED SERVICE, OR REPLACE THE COMPLETE FAN.
	UNBALANCED IMPELLER OF THE FAN ROTATES FREELY, BUT VIBRATES SHORTLY WHEN THE FAN IS TURNED ON.	DISMANTLE THE FAN AND GIVE IT TO A PROFESSIONAL SERVICE FOR BALANCING.
INSUFFICIENT HEAT CAPACITY OF THE HEATER UNIT	THE EXCHANGER IS BLOCKED.	DISMANTLE THE FAN AND CLEAN THE EXCHANGER. USE PREFERABLY HOT WATER OR STEAM FOR CLEANING. DO NOT USE AGGRESSIVE DETERGENTS.
	STOP OR REGULATION VALVES ON THE DEVICE ARE NOT FULLY OPEN.	OPEN FULLY THE STOP VALVES, AND CHECK WHETHER THE REGULATION VALVE IS OPEN.
	INCORRECT ROTATION DIRECTION OF THE MIXING VALVE.	CORRECT EL. CONNECTIONS ON THE TERMINAL BOARD OF THE REGULATION.
	CLOGGED FILTER.	REPLACE OR CLEAN THE FILTER THOROUGHLY.
THE FAN IS NOT WORKING	NO POWER SUPPLY OR CONTROL VOLTAGE	CHECK THE MAIN POWER SUPPLY OR CONTROL SIGNAL
	MOTOR IS OVER HEATED. CHECK TEMPERATURE AND CHECK IF FAN IS POSSIBLE TO ROTATE.	INTEGRATED THERMAL PROTECTION DISCONNECTED THE MOTOR. TRY FUNCTION AFTER MOTOR WILL COOL DOWN - NEEDED POWER ON RESET

IF YOU CANNOT FIND, REMOVE THE DEFECT OR IF IT REQUIRES INTERVENTION TO THE DEVICE, PLEASE CALL AN AUTHORISED SERVICE!

IF YOU CANNOT CLEAR THE FAULT BY YOURSELF

IF YOU CANNOT SOLVE THE PROBLEM, PLEASE CALL THE SUPPLIER.

PROVIDE FOLLOWING INFORMATION TO GET A PROMPT SOLUTION:

- PRODUCT TYPE
- SERIAL NUMBER
- OPERATION TIME
- ACCESSORIES USED
- INSTALLATION PLACE
- INSTALLATION CONDITIONS (INCL. ELECTRICAL)
- DETAIL DESCRIPTION OF THE FAULT AND STEPS MADE TO ITS REMOVAL

WARRANTY AND AFTER-WARRANTY SERVICE IS PROVIDED BY THE MANUFACTURER, SUPPLIER OR AUTHORISED SERVICE ORGANISATION. WHEN ORDERING A SERVICE INTERVENTION, IT IS NECESSARY TO PROVIDE FAULT SPECIFICATION, UNIT TYPE ON THE LABEL, AND PLACE OF INSTALLATION.



READ CAREFULLY

PRODUCT DISCHARGE FROM OPERATION – DISPOSAL

BEFORE YOU DISCARD THE PRODUCT, MAKE IT UNUSABLE. EVEN OLD PRODUCTS CONTAIN RAW MATERIALS THAT CAN BE REUSED. DISPOSE THEM IN THE COLLECTION POINT FOR PROCESSED RAW MATERIALS.

IT IS BETTER TO LET THE PRODUCT DISCARD IN A PLACE SPECIALISED FOR SUCH PURPOSE, IT WILL ALSO BE POSSIBLE TO REUSE RECYCLABLE MATERIALS. DISPOSE UNUSABLE PARTS OF THE PRODUCT IN A CONTROLLED DUMPING SITE.

WHEN DISPOSING MATERIALS, IT IS NECESSARY TO COMPLY WITH RESPECTIVE NATIONAL REGULATIONS FOR WASTE DISPOSAL



ACCESSORIES

VARIOUS ACCESSORIES MAY BE PURCHASED TO THE HEATER UNIT SAVANA. FOR DETAIL INFORMATION SEE TECHNICAL SHEET OF THE PRODUCT.



CHECK THE SUPPLY

FOR CORRECT AND SAFE USE OF THE UNIT, IT IS NECESSARY TO READ THIS MANUAL AND COMPLY WITH THE ABOVE MENTIONED.

FOR ANY INQUIRY OR REQUEST FOR EXPLANATION, PLEASE DO NOT HESITATE TO CONTACT OUR BUSINESS DEPARTMENT OR THE DEPARTMENT OF TECHNICAL SUPPORT.

CONTACT

2VV, s.r.o.
Nádražní 794
553 51 Pardubice
Czech Republic

WEBSITE

<http://www.2vv.cz/>

