



PARTNER  
IN VENTILATION  
2VV.CZ

**EN**



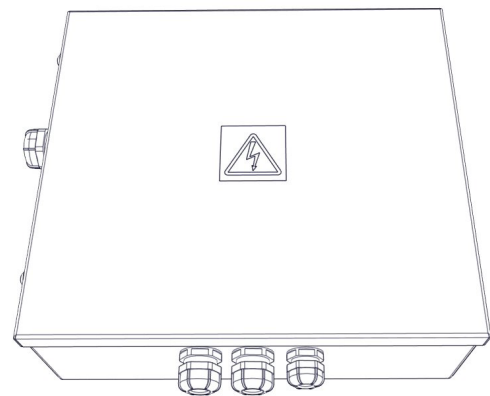
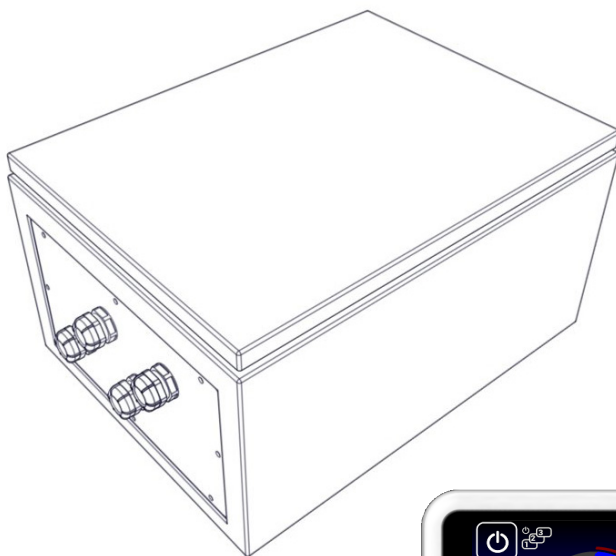

**SC-C/S**

**MANUAL  
INSTALLATION AND OPERATION**



# 1. BEFORE YOU BEGIN

The following symbols in the manual serve for better guidance. The following table describes the symbols and their meaning.

Symbol	Meaning
 <b>CAUTION!</b>	Warning or Caution
 <b>DO NOT SKIP!</b>	Important instructions
 <b>YOU WILL NEED</b>	Practical tips and information
 <b>TECHNICAL INFORMATION</b>	Detailed technical information
	Reference to a different part of the manual



Before you begin the installation, **thoroughly read the manual** to safely and properly using this product.

This manual provides instructions on how to properly install the unit. Before installing the unit, carefully read the entire manual. The manufacturer reserves the right to make changes, including in the technical documentation, without prior notice. Keep the manual in a safe place for future reference. The manual is an integral part of the product.

## Declaration of conformity

The product has been designed, produced and marketed in compliance with all the applicable provisions, and abides to the provisions of the European Parliament and Council, including the amendments under which it has been classified. It is safe under normal conditions and under the conditions laid down by the manual. The assessment was conducted pursuant to harmonized European standards included in the relevant EC Declaration of Conformity. The current and full version of the EC Declaration of Conformity can be found at [www.2vv.cz](http://www.2vv.cz)

## 2. UNPACKING

### 2.1 INSPECT THE DELIVERY

**DO NOT SKIP!**



- Unpack the product upon delivery and control for damages. In case of damage, inform and file a report with the carrier.
- Any claims that have not been filed in due time, will be disregarded later.
- Check that you have received the model ordered. Should the delivered model differ from the one ordered, do not unpack the unit and notify the supplier immediately.
- After unpacking the product, check that the unit and the accessories are in good order. Contact the supplier in case of any doubt.
- Do not attempt to commission a damaged unit.
- In the event that you decide not to unpack the unit immediately after delivery, it must be stored in a dry place with temperatures ranging **from +5 °C to +40 °C**.
- This product must not be used by persons (incl. minors) with mental or physical disabilities, or insufficient experience or knowledge in the safe use thereof, unless they are supervised or instructed on how to use the product by a person responsible for their safety.
- Do not let children play with the unit.

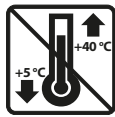

	<p>All the packing material is environmentally friendly and can be reused or recycled. Please, contribute actively to the protection of the environment and procure the regular disposal or recycling of packing materials.</p>	
--	---	--



**DO NOT SKIP!**

- If the unit was shipped at temperatures below 0°C, let it rest for at least 2 hours without turning it on, so that its interior temperature can match the surroundings.

#### SC-C-ACx

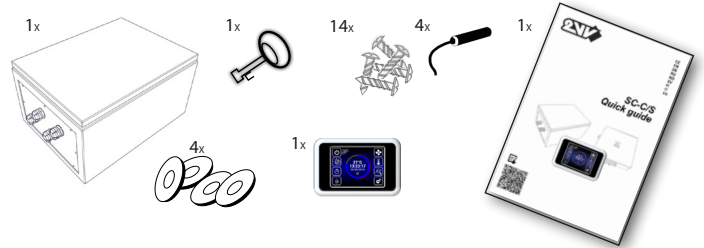

#### SC-S-ACx

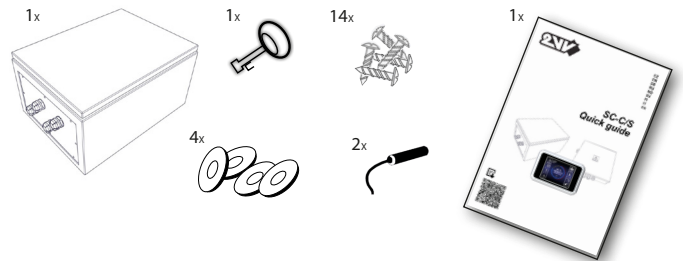

#### SC-C-EC

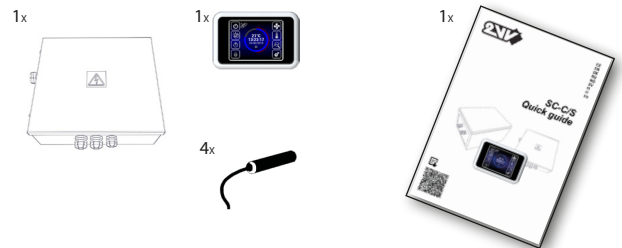

#### SC-S-EC

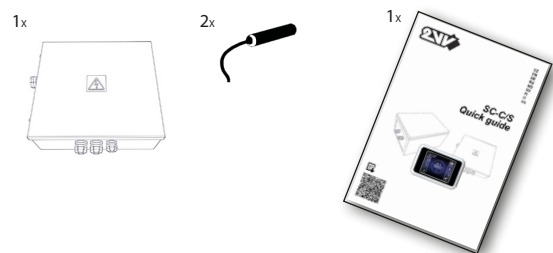

### 3. MAIN SECTION SC-x-ACx

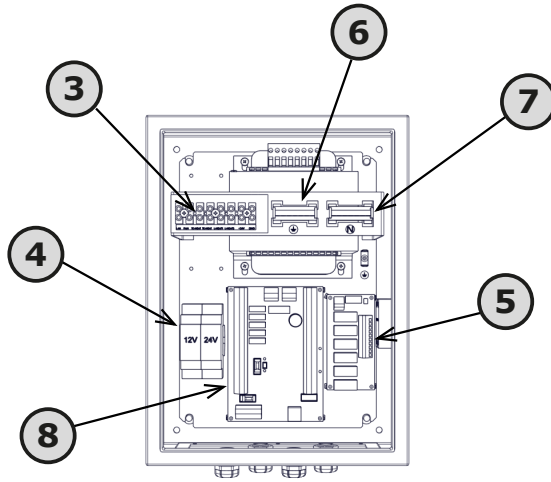
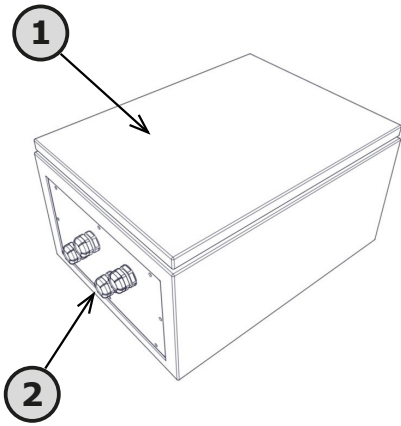

### SC-x-EC

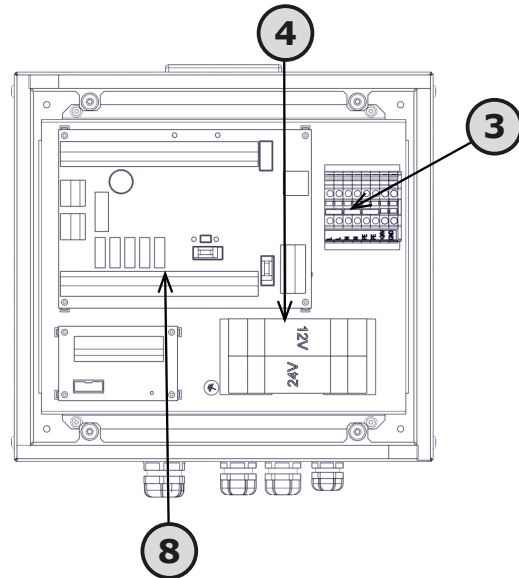
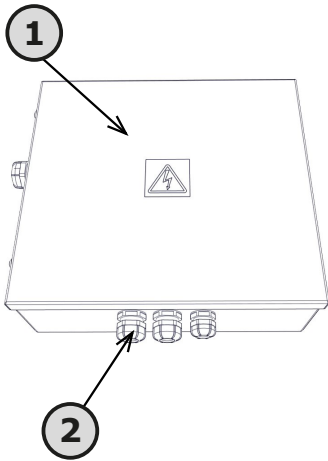

1	Regulator lid
2	Cable housing
3	Connecting distributor plate
4	Source
5	AC module
6	Grounding bridge (PE)
7	Null bridge (N)
8	Controlling electronics

# 4. DIMENSIONS

## SC-x-ACx regulation box

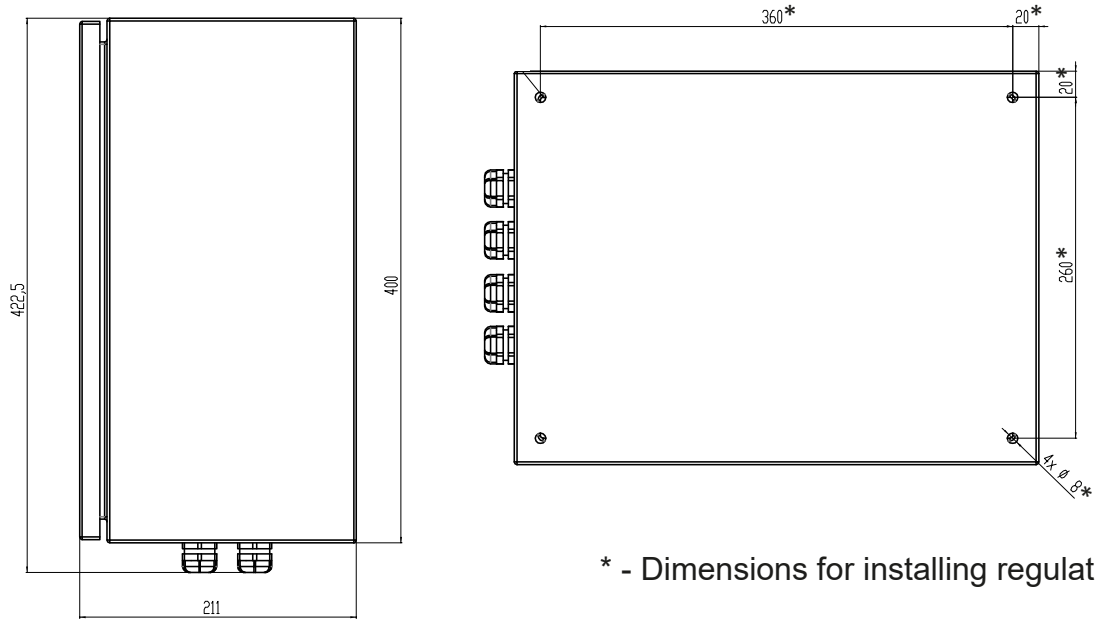

\* - Dimensions for installing regulation on wall

## SC-x-EC regulation box

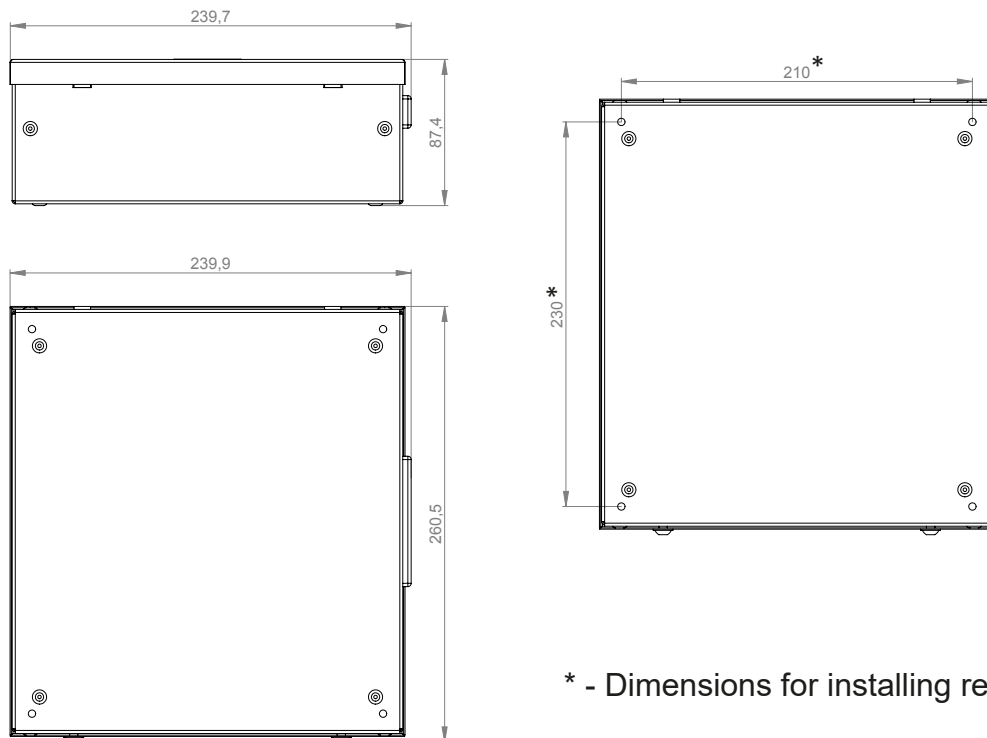

\* - Dimensions for installing regulation on wall

## 5. TECHNICAL PARAMETERS

Type	Voltage [V/Hz]	Maximum current AC fans [A]	Electric sheathing [IP]	Weight [kg]	Maximum number of connectible EC fans [units]
SC-C-AC5-04	230 / 50~60	4	65	13.5	---
SC-C-AC5-07	230 / 50~60	7	65	15	---
SC-C-AC5-16	230 / 50~60	16	65	23	---
SC-S-AC5-04	230 / 50~60	4	65	13.5	---
SC-S-AC5-07	230 / 50~60	7	65	15	---
SC-S-AC5-16	230 / 50~60	16	65	23	---
SC-C-EC	115~230 / 50~60	---	40	3	10
SC-S-EC	115~230 / 50~60	---	40	3	5

## 6. INSTALLATION

### 6.1 SELECT INSTALLATION SITE



The assembly and above all the connection of the control unit may only be carried out by a trained person with the appropriate permit for connecting electrical devices who has suitable tools and resources available. During assembly it is necessary to uphold all instructions and recommendations stated in this manual.



#### TECHNICAL INFORMATION

The regulator must be operated in places corresponding to the given coverage according to the IP.

### 6.2 ASSEMBLY TO WORKING POSITION

The regulator is to be installed on a wall in a vertical position.

The regulator must be installed in such a way that air may flow around it and that it may not overheat.

Maintain the minimal recommended clearance distance.

The regulator must be installed in such a way as to ensure sufficient access in the event of maintenance, servicing, or disassembly.

The regulator is fixed to the wall using screws and anchors or bolts.

No flammable materials may be kept within 100 mm of the regulator.

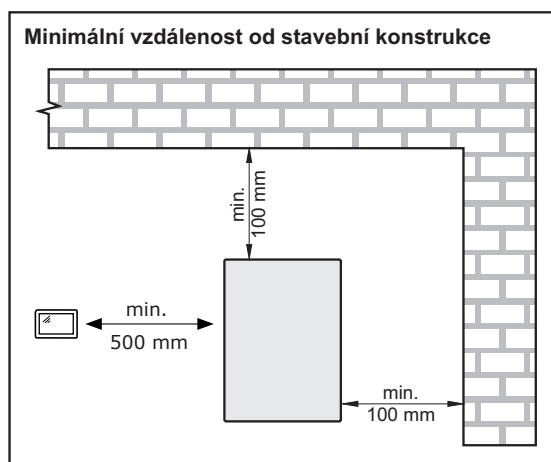

## TECHNICAL INFORMATION

For installation of the AC version of the regulator onto the wall, we recommend separating the internal section (electronics and transformer) from the regulator box for easier handling.

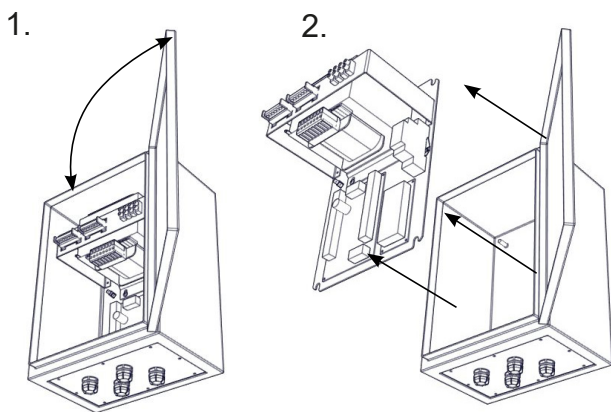

**The regulator must be installed as shown in the pictures, i.e. with bushing downward.**

- To mount the regulator, use the corresponding anchors and screws.
- To preserve the IP cover of the box, use screws and washers provided



- Drill
- 4x screws
- 4x anchors
- 4x washers with sealing rings (included)

## 6.3. INSTALLATION AND ASSEMBLY OF ELECTRONICS

### CAUTION!

- The regulator must always be disconnected from the main power supply prior to opening the unit.
- The installation can be carried out only by a professional with qualifications in electronics.
- The manual must be followed, along with the laws and regulations applicable in the given country.
- The unit must be connected to the main power source with an insulated cable with heat resistance compliant with the diameter and applicable laws and regulations of the given country.
- All phases of the electrical intake to the regulator must be connected via a protective power breaker corresponding to the current and model.



- The distance between disconnected contacts must be greater than 3 mm.
- The nominal values of the electrical parameters of the unit are listed on the manufacturer's label.
- The main intake of electrical power, switching elements, accessories should be connected according to the connection schematic.
- The connected fans may not exceed the nominal value of current of the control unit!
- Opening and modifying the internal connection of the control unit is prohibited and can void the warranty.
- In case of fire, it is necessary to extinguish the device with power or CO2 fire extinguisher.
- The unit must be connected in such a way that it can be disconnected from the power supply with one piece.

### Recommended breakers:

Table of minimum sizes of breakers according to the regulator model.

The suitability of the breaker always depends on the specific conditions at the site of installation. The following table is for orientation purposes only!!!

AC-C	
SC-C-AC5-04	6A
SC-C-AC5-07	10A
SC-C-AC5-16	20A

AC-S	
SC-S-AC5-04	6A
SC-S-AC5-07	10A
SC-S-AC5-16	20A

EC	
SC-C-EC	16A
SC-S-EC	16A

### Activating remote control

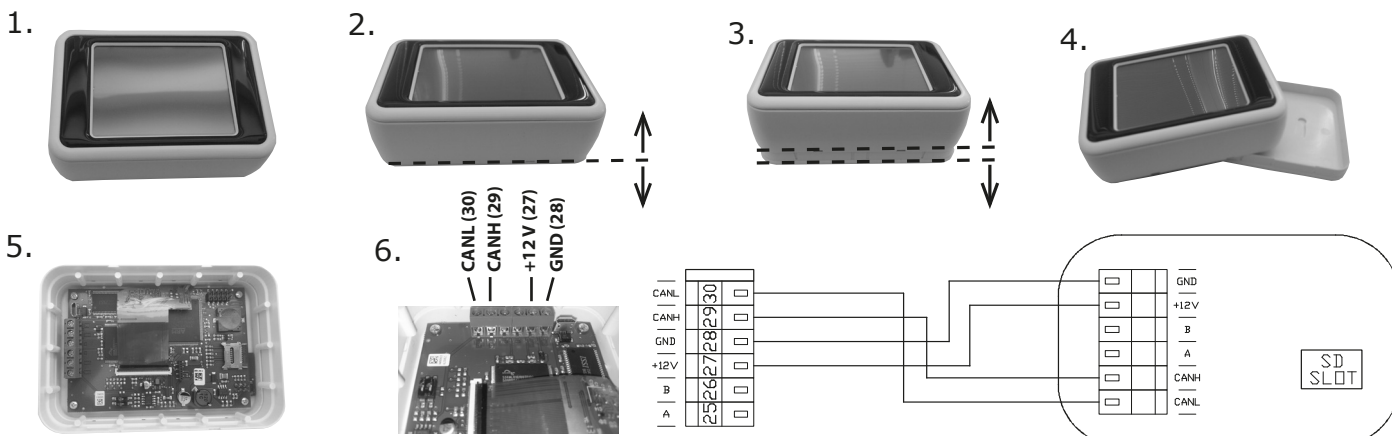

# 6. INSTALLATION

## SC-C-AC



MASTER UNIT

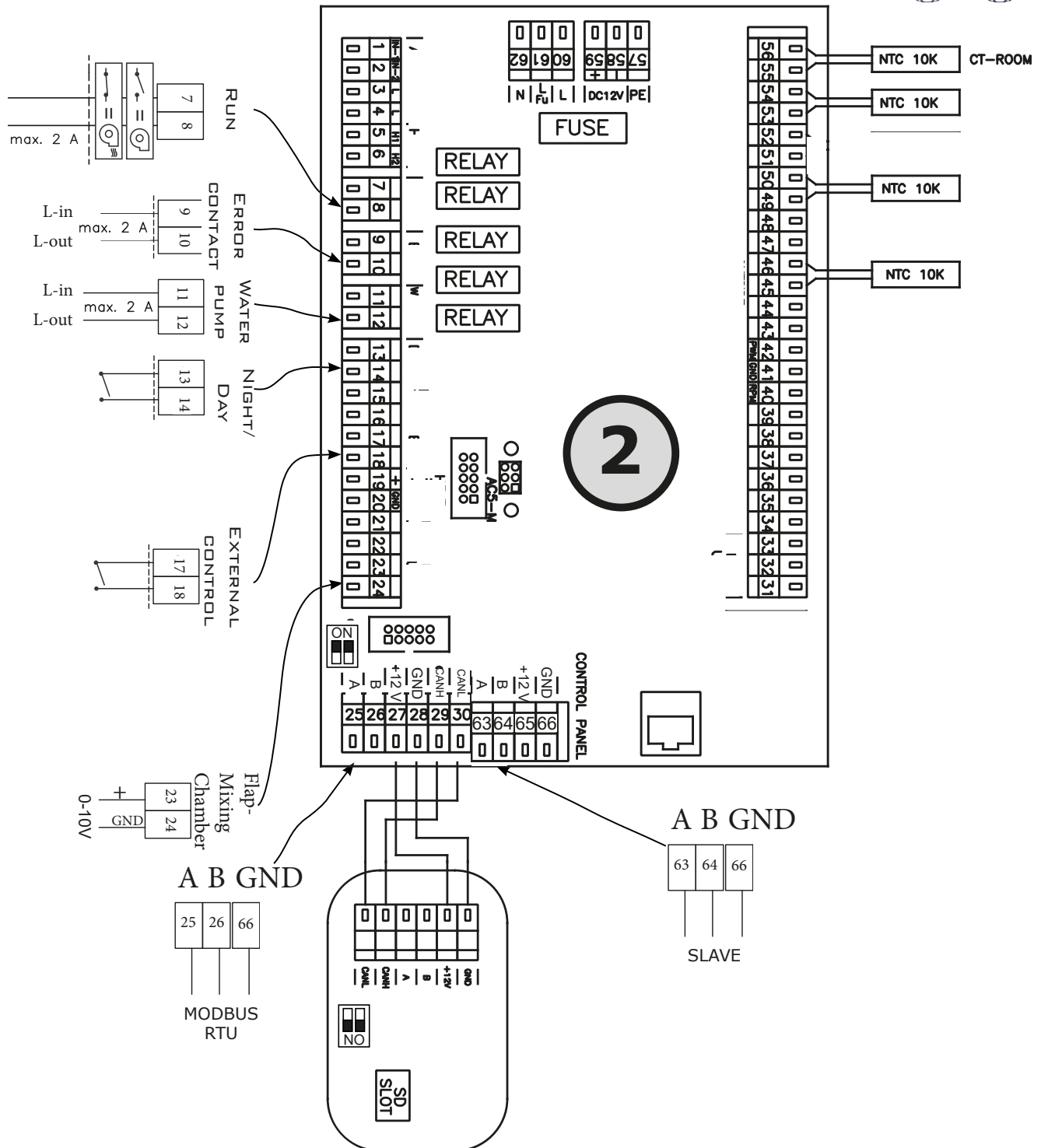
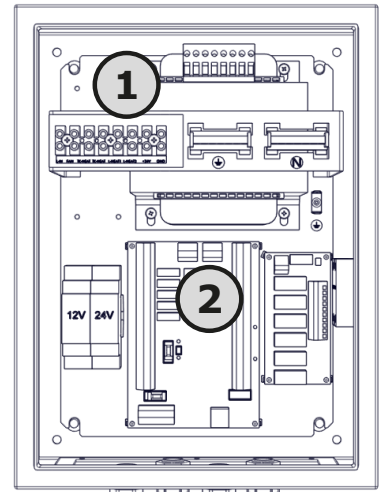

# 6. INSTALLATION

## SC-S-AC



SLAVE UNIT

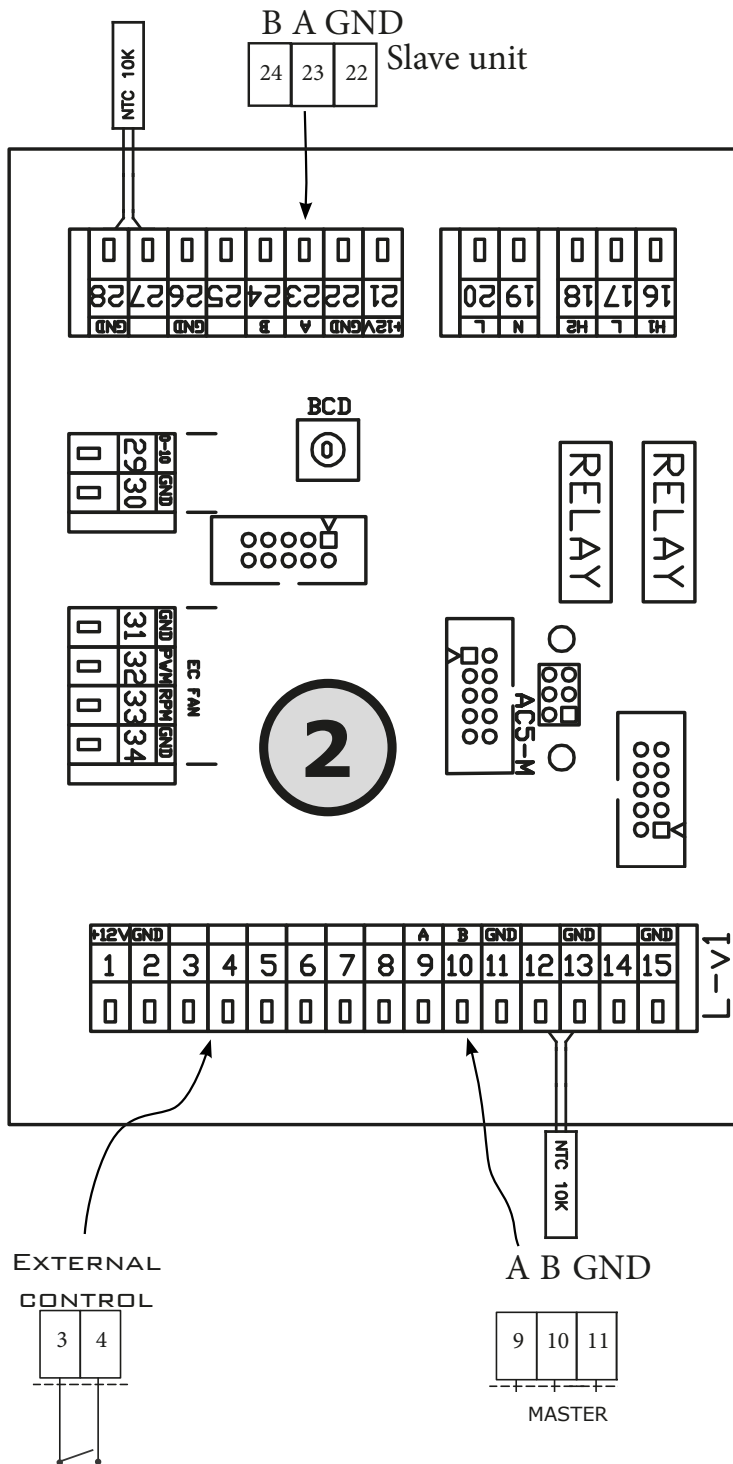
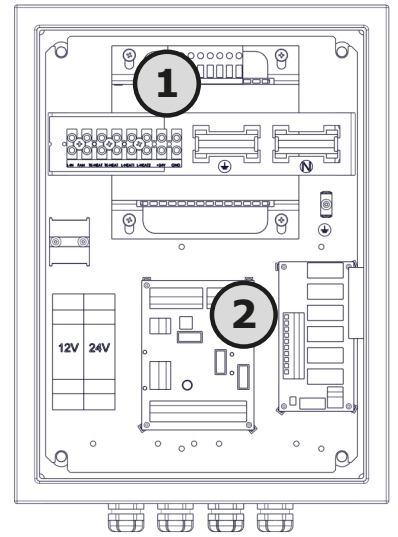

# 6. INSTALLATION

## SC-C-EC

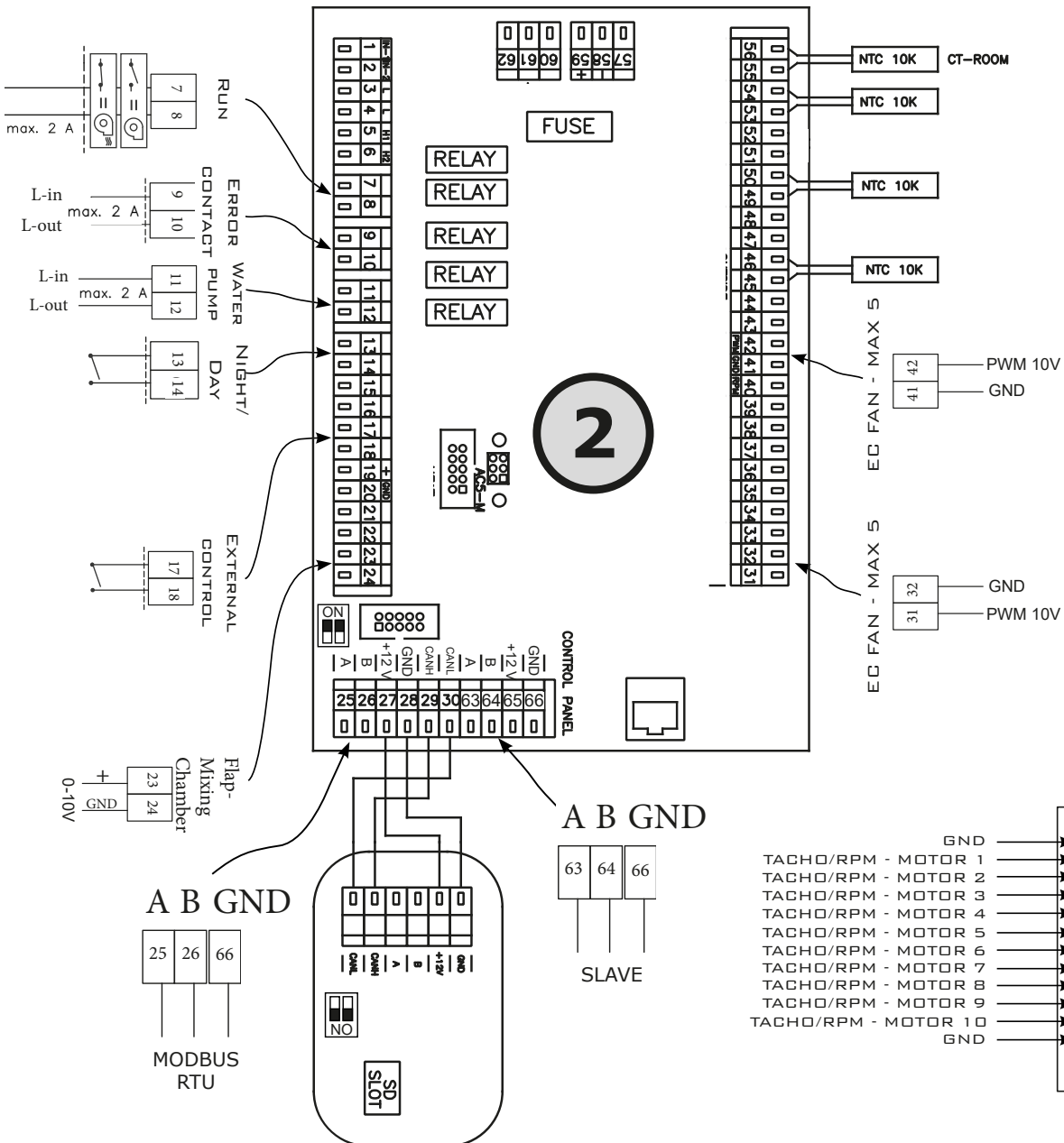
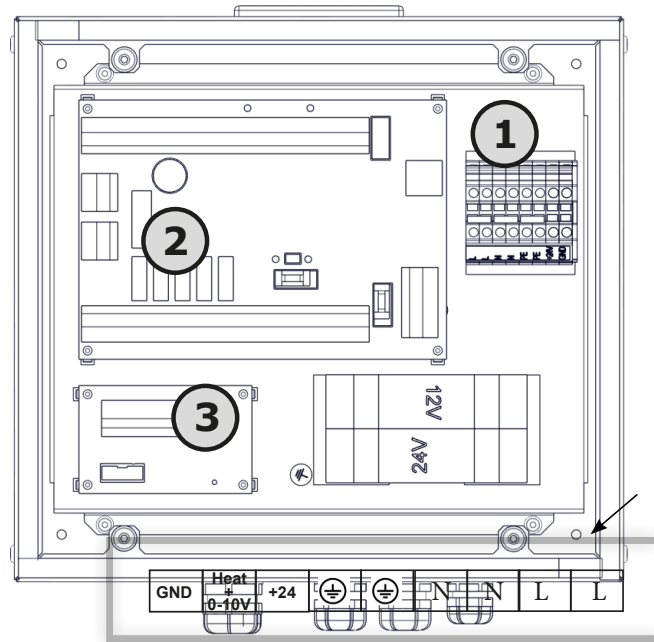
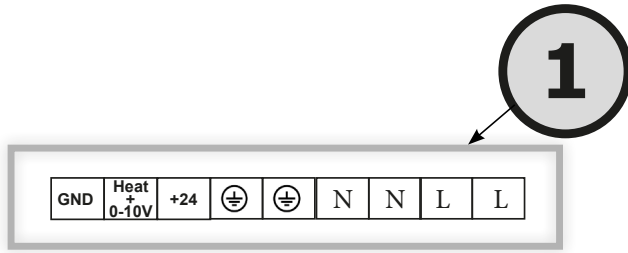

# 6. INSTALLATION

## SC-S-EC

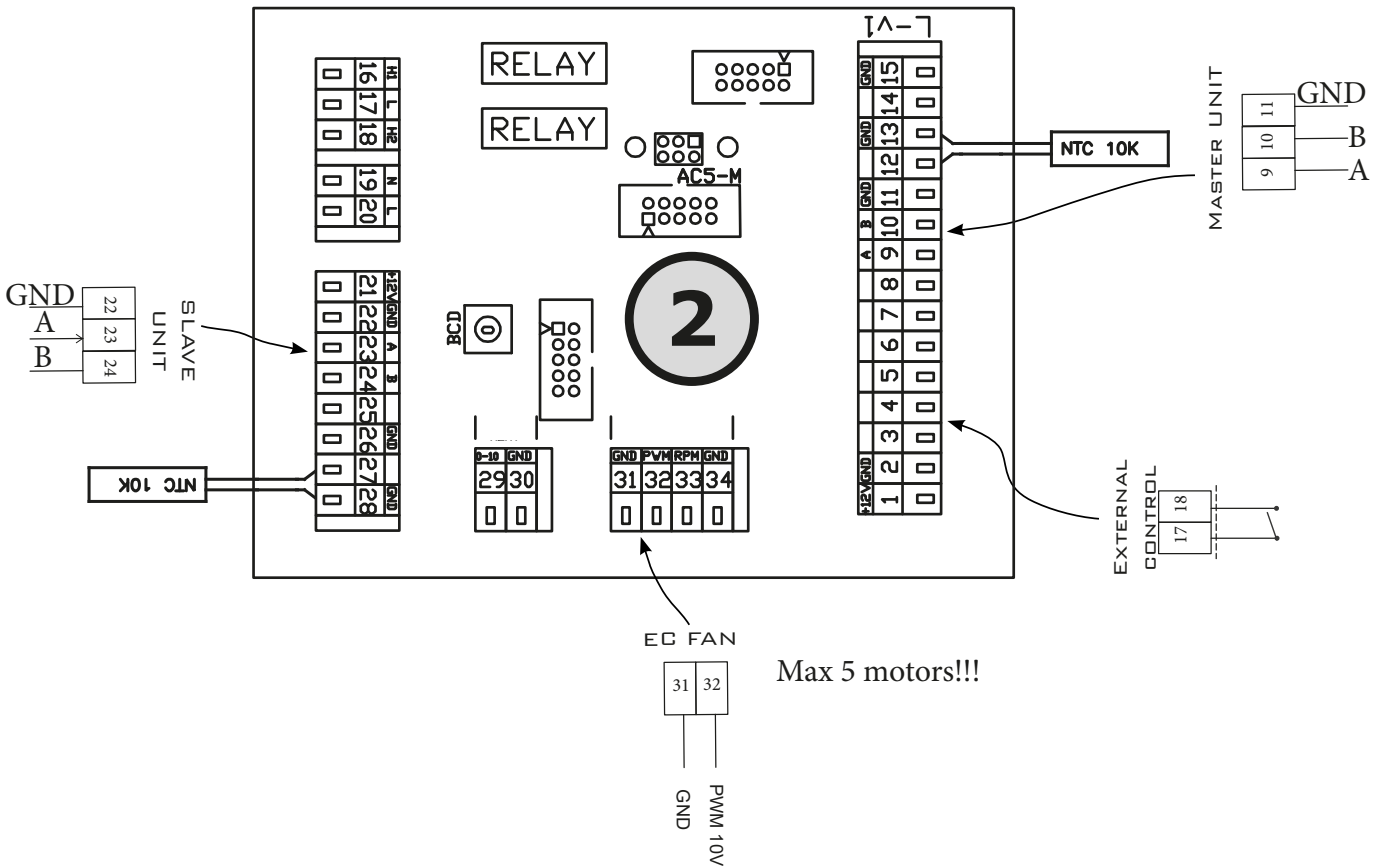
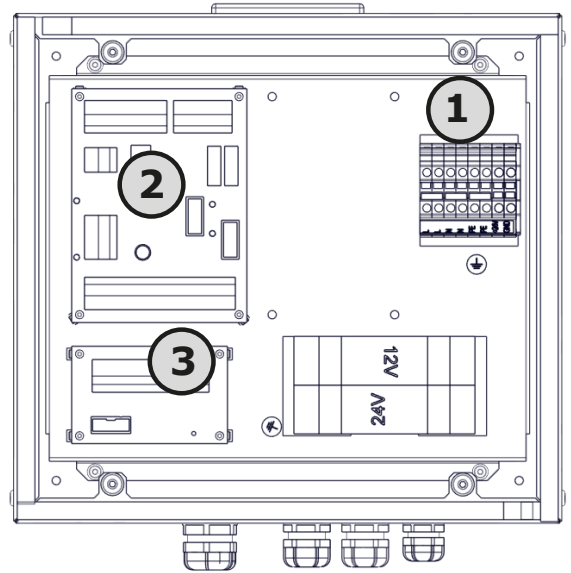
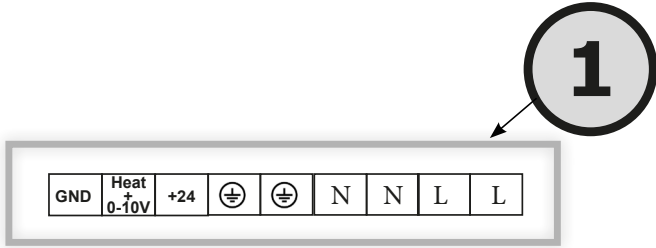

When designing the wiring for the drive power of the EC engines, it is necessary to take into consideration any possible decrease in power!!!

**The minimum power for the lowest engine performance is 1.5V!!!**

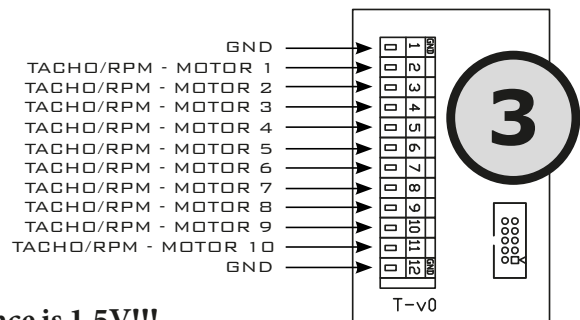

# 6. ELECTRONIC SCHEMATICS CHAINING

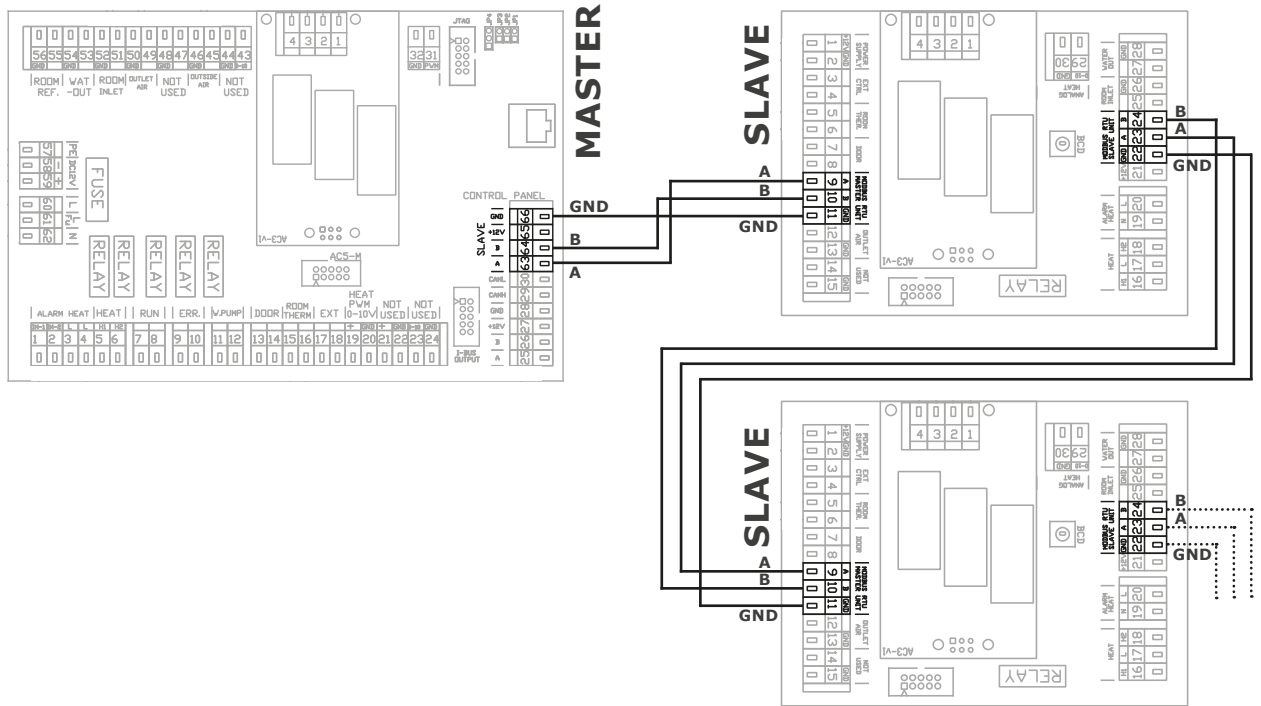
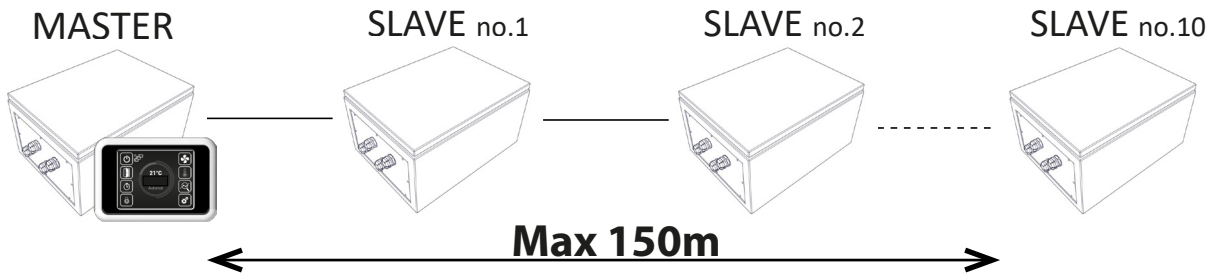

The total length of the bus of all chained shutters may not exceed a length of 150m!!!

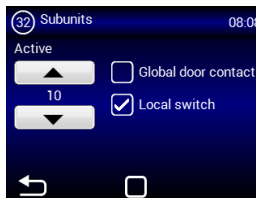
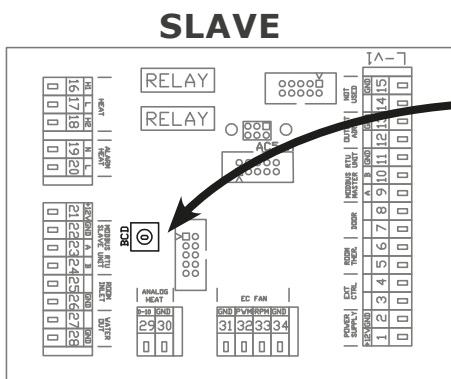

SLAVE	BCD	SLAVE	BCD
NO.1	1	NO.6	6
NO.2	2	NO.7	7
NO.3	3	NO.8	8
NO.4	4	NO.9	9
NO.5	5	NO.10	A

# 7. OPERATION

## READ CAREFULLY!

**Before deploying into operation, check the following:**

- that the device is properly fixed on a load-bearing structure
- that the device has been properly closed
- that the electrical power has been properly connected, including grounding and protection of exterior starters.
- that all elements of electrical parts have been properly connected
- that the installation corresponds to all instructions given in this manual
- that no tool or other object that can damage the device has remained in it

## CAUTION!

- Opening and modifying the internal connection of the control unit is prohibited and can void the warranty.
- We recommend using the accessories we provide. Contact your supplier in case of doubts with the use of non-original accessories.

## DEPLOYMENT

After activating the main power supply, the display of the controller lights up and servicing data is downloaded. The device is prepared for deployment only after all servicing data has been downloaded.

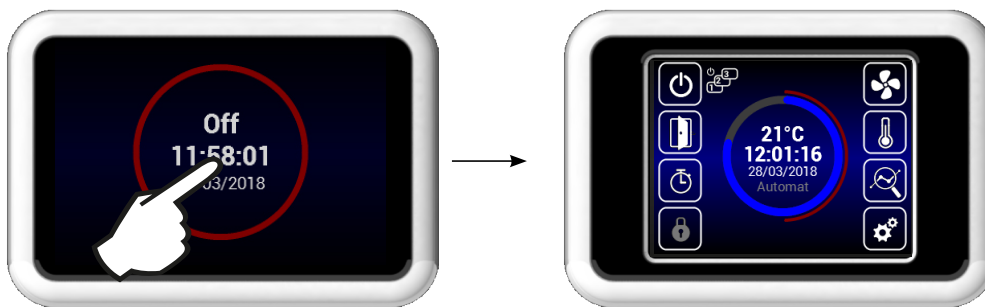

Remote control contains a touch-screen – the device is operated by touching the symbols on the screen.

## Description of main screen

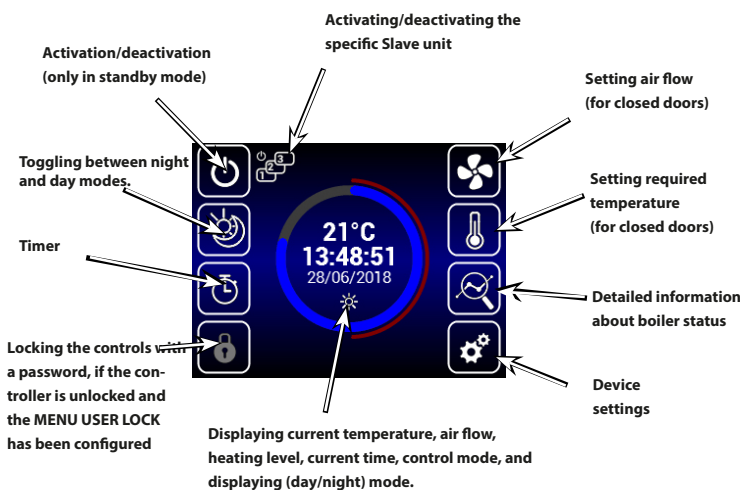

## Warning icons

These symbols warn of an error; by clicking on the symbol of a warning icon a screen is shown with the given error messages

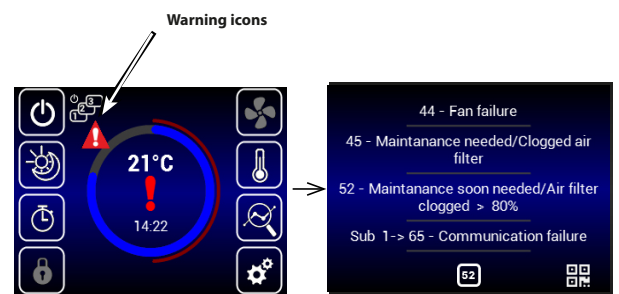

## Informational icons

This symbols merely inform about status, and do not indicate an error

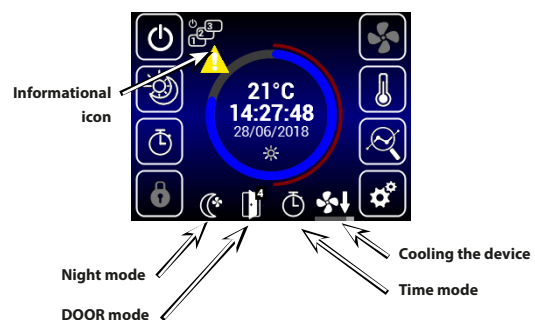

The individual MENUs are described later in this manual

- page 13
- page 14
- page 17

# 7. OPERATION



## Current status

This screen displays detailed status of the shutter and sensor values:

- Current set air flow (step or %), informational icons
- Air temperature for intake\*, exhaust\*, room temperature\*, and temperature outside the building\*
- (\* - in the event that the necessary sensors are installed and enabled)
- Set heater power (if included)

Exterior temperature 16°C

mixing shutter

displaying the need for servicing

Spatial temperature 20°C

Return to previous screen

SP= required temperature

Indication of heating blockage (summer mode)

Information about unit type

green color indicates active sensor

If there are SLAVE shutters connected, the information from them is displayed here. Access to them is available by shifting the screen upward.

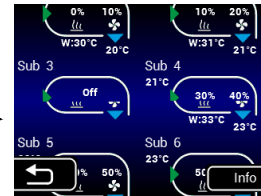

Settings can be found in these instructions in the "SUBUNITS" menu.



## MENU Settings

Display backlight

Language

Date and time

Setting air flow (for closed doors)

Timer

Setting required temperature (for closed doors)

Return to previous screen

NFC/QR CODE

Parameters



## Settings required temperature for closed doors

Setting DAY temperature

Required temperature settings-menu 09

Reducing or increasing required temperature

Required power Automatic mode = °C

Confirm + return



In the event that heating is suspended by summer mode (MENU - SUMMER HEATING), the "Sun" icon is displayed here without the option to select power.



## Setting air flow for closed doors

Displaying the required air flow (step by 20%)

Displaying the current status of air flow

Reducing or increasing air flow through shutters (for closed doors)

Confirm + return



Blower power with closed doors may be limited in the menu 1616 Adv. fan setting. After exceeding the limit, the blower power is restricted according to the limit.

## Setting NIGHT temperature

This mode can be toggled on the controls, or using the Night/Day button attached to the regulator. clamp number 13, 14.

Setting NIGHT temperature

Temperature 09:09



## Setting date and time

Setting current date and time

Confirm + return

Return to main screen

# 7. OPERATION



## Timer

Unless settings dictate otherwise, the device will transition into Standby mode once the time interval has passed. This function does not take fan settings into consideration.



## Week mode

Various time modes may be set by touching any given day.

Button for copying daily plan to other days



## Year mode

Touch to add new time mode

When activating this field the regulator turns off at the set time on the timer.

This setting is not observed in the timer mode.

Desired heating power.



## Language



Any of 10 different language interfaces may be selected.



## Backlight settings

Level of backlight in activated status

Level of backlight in standby status

Confirm + return

Return to main screen

# 7. OPERATION



## Servicing menu

Use code 1616 to access the servicing MENU

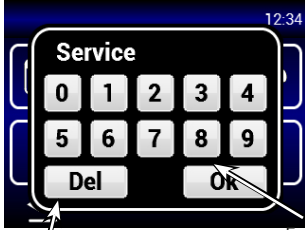

1616

Delete/go back

Enter menu

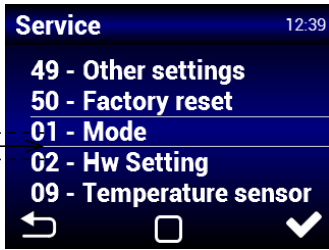

Enter selected menu

Select the MENU after scrolling to the middle of the page and clicking to enter

## MENU - MODE

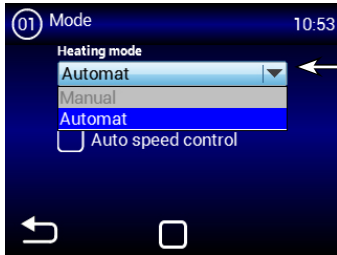

Only automated mode can be set for this regulator.

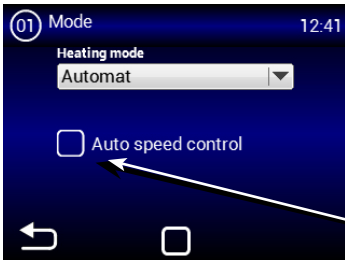

Activation/deactivation of automatic motor rotation control by temperature

## MENU - HW SETTING



In this MENU you can set the detailed behavior of the individual regulator inputs and outputs

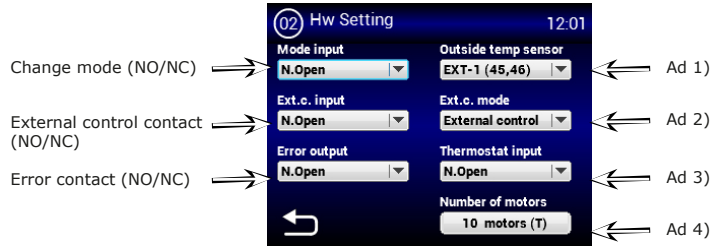

**Ad 1)** - Activation/settings of outer temperature sensor. Available selections: **None** - sensor not connected/inactive **EXT-1 (45,46)** - sensor connected (must be on connectors 45 and 46)

**BMS** - active temperature sensor and used from master system

**Ad 2)** - Setting the behavior of external contact input. Available selections: **None** - inactive **External control** - External activation/deactivation of device

**Ad 3)** - Not used.

**Ad 4)** - Number of connected EC motors on regulator: 0-10ks  
Don't forget to connect the speed outputs of the motors to the appropriate connectors  
on the panel of the regulator, per the following schematic:

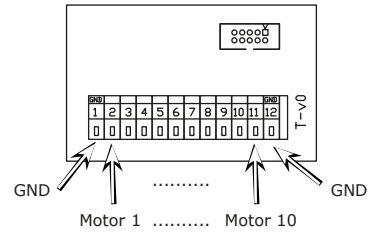

If the situation should occur that it is not required to check the speed output of the motors, this function can be blocked:

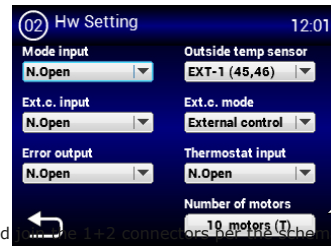

In the quantity of the "number of motors" menu, select the value "1"  
And connect the 1+2 connectors per the schematic below.

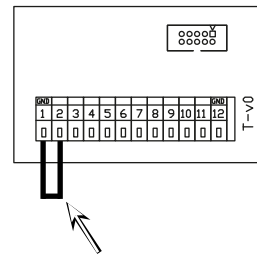

If no engine with tacho or termo contact is connected. **Connectors 1 and 2 must be connected.**

# 7. OPERATION

## MENU - FILTER TIMER



This MENU allows you to set the time (by motor hours) after which an alert to replace filters is displayed, if applicable, to re-set the timer after replacing filters

Setting the desired time until an alert appears on the main screen of the display

1000 h ~ 5000 h

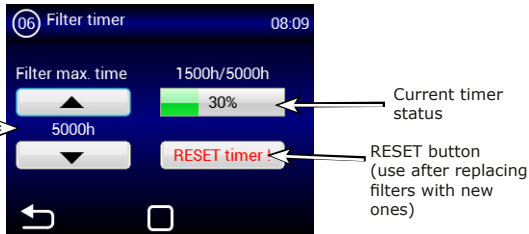

Sample display of status of fouled filter on main screen

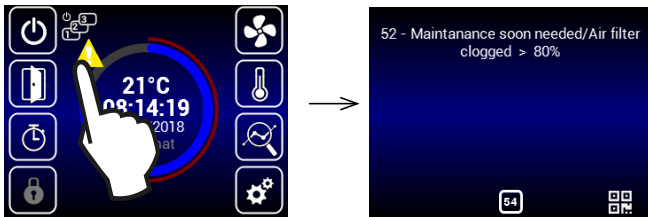

## MENU - TEMPERATURE SENSOR



**Available in Automatic Mode only.**

In this menu the temperature sensor that will be used for primary temperature control can be selected

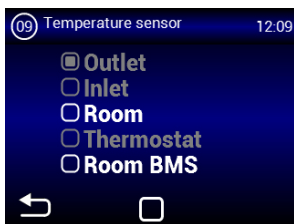

Available selections:

**Room** - Spatial temperature sensor (e.g. in a room)

**Room BMS** - Spatial temperature sensor from master system

## MENU - PID params

Setting PID values for the exchanger.

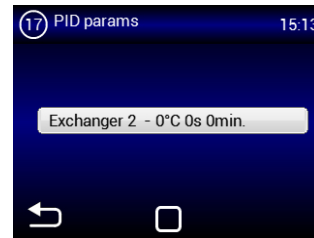

Incorrect settings can lead to poor heat exchanger functioning!!!

## MENU - MODBUS RTU



This MENU allows for the setting of communications parameters for the Modbus RTU

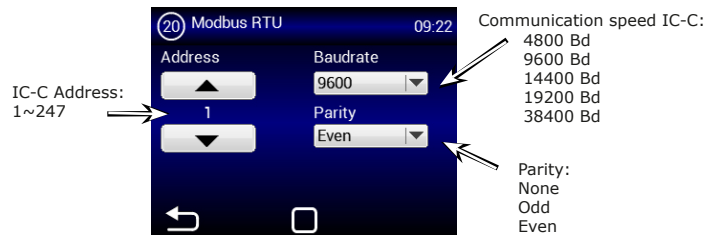

Incorrect settings can lead to inability to communicate with the regulator

## MENU - NETWORK



This MENU allows for the setting of communications parameters for network interfaces

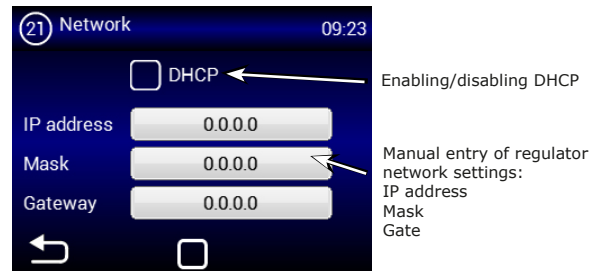

Incorrect settings can lead to inability to communicate with the regulator

# 7. OPERATION

## MENU - USER LOCK

This MENU allows for setting restrictions on the control of the regulator using panels at various levels

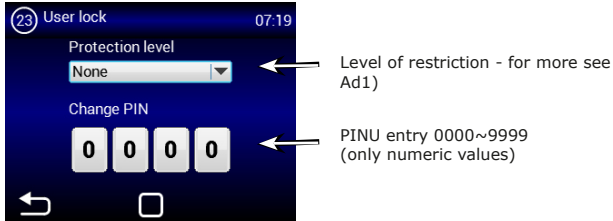

**Available selections:**

- None** - Restriction not active
- On/Off** - Only the option to activate/deactivate and access to the information menu are accessible from the main screen.
- On/Off, Temp, Flow** - The following are available without password: Activate/Deactivate, Information menu, Temperature Settings, Air Flow Settings
- Full** - Only the information menu is available without a password
- User mode** - Special user mode, see image below



## MENU - SUMMER HEATING

This MENU allows for the setting of heating restrictions in summer months

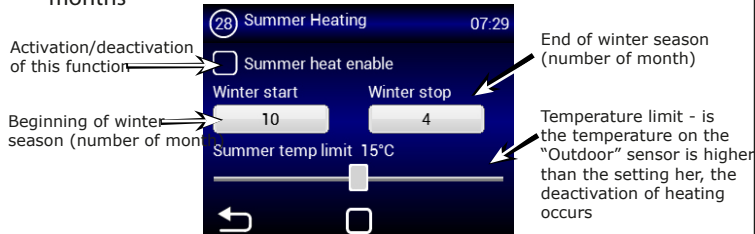

If the outdoor temperature sensor is not set, the "summer heating" mode operates only according to the selected time and the set temperature is not assessed

## MENU - WATER ANTIFREEZE

This MENU is available only for units with water heat exchanger

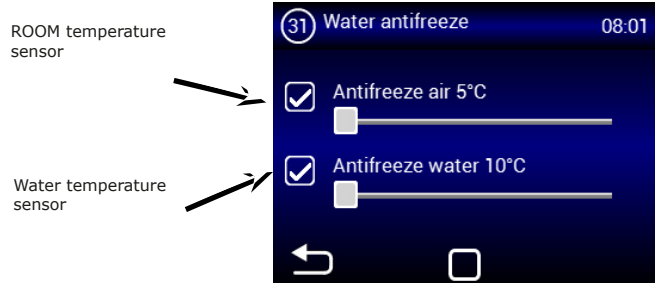

The menu serves to define protection of the water heat exchanger. In the event of checking both sensors, both values must be exceeded for the heat exchanger protection function to be activated. If no sensor is selected, anti-freezing protection of the heat exchanger is deactivated.

## MENU - SUBUNITS

This MENU allows for setting the behavior of other regulators connected as "SLAVE"

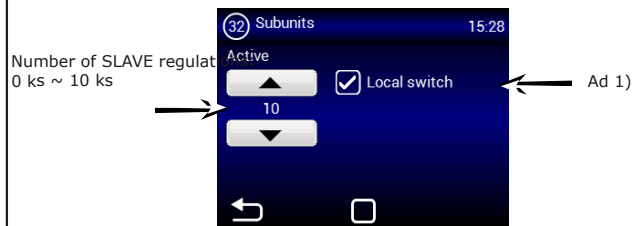

**Ad 1)** - Option to activate icon on the main screen that can allow for deactivating/activating the individual SLAVE regulators. If this function is not active, all SLAVE regulators will activate/deactivate at once.

- Function disabled = Global switching/switching off of SLAVE regulators
- Function enabled = From the main screen the individual SLAVE regulators can be selected for activation/deactivation

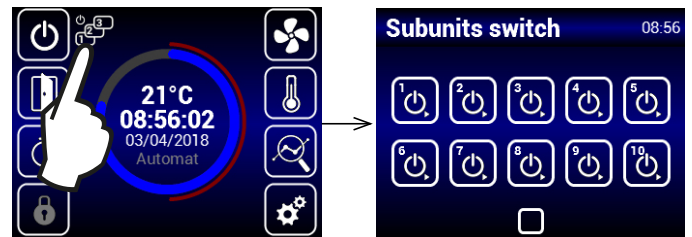

# 7. OPERATION

## MENU - Adv. WATER SETTING

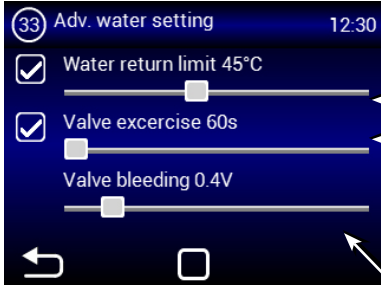

Maximum temperature for return water

Setting periods for blower movement. Only at 0:00 time and in Standby mode.

The minimum throughput of water can be set only for analogue fan control. This function is active in Standby mode as well.

## MENU - Damper control

This MENU allows for setting the mixing shutters, which intake exterior air into the interior space. This is active only in DAY mode with Outlet limitation room enabled in MENU 37.

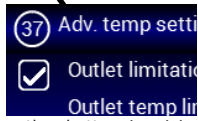
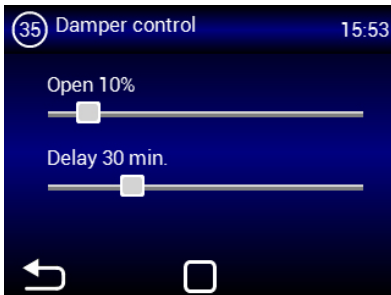

Setting the shutters in mixing mode.

Delay for instruction of mixing mode when toggling DAY/NIGHT

## MENU - Fan limits

MENU for setting exhaust temperature limits.

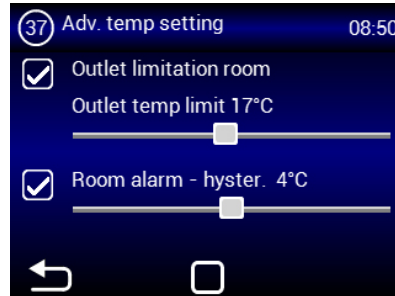

Setting exhaust temperature limits after reaching a temperature in the space.

If the exhaust temperature set decreased by the desired temperature (Room alarm), the mixing shutter will be closed, the contact alarm heater will be bound and an error will be reported.

## MENU - OTHER SETTINGS

This MENU allows for setting other parameters

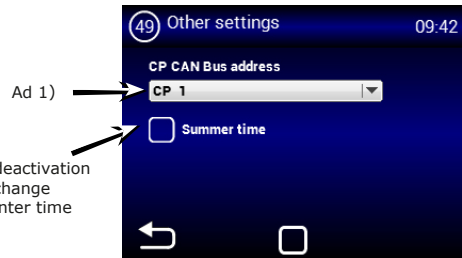

Activation or deactivation of automatic change of summer/winter time

**Ad 1)** - Option to set CAN address of control panel such that up to 2 control panels can be connected to MASTER regulation  
Options: CP 1 = control panel has address 1  
CP 2 = control panel has address 2

## MENU - Fan limits

MENU for fan settings

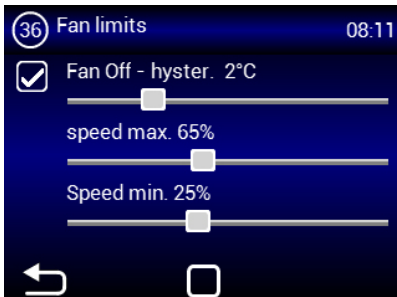

When exceeding the desired temperature by a set amount (Fan Off), the fan is deactivated.

Setting maximum fan power.

Setting minimum fan power.

After reaching the desired temperature in the space, the fan and the heating are deactivated. During temperature drops by the set hysteresis, the fan and heating once again reactivate.

# 7. OPERATION

## CAUTION!

Each panel must have its own address.  
If this is not observed, it can result in improper functioning of the regulator.

When connecting multiple panels it is necessary to set the termination elements. These can be found on the main electronics and in the control:

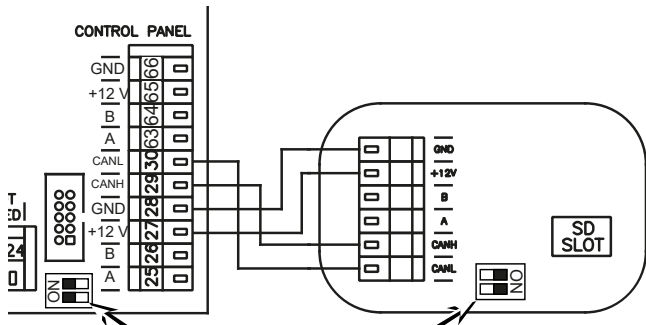

Setting termination elements

Example of connecting controllers - Option 1:

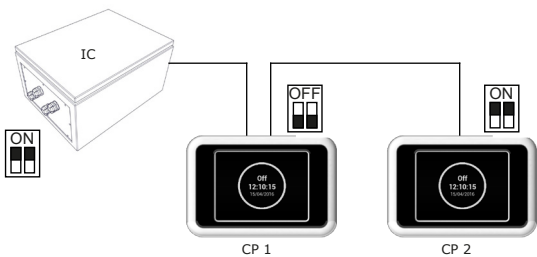

Electrical connection - Option 1:

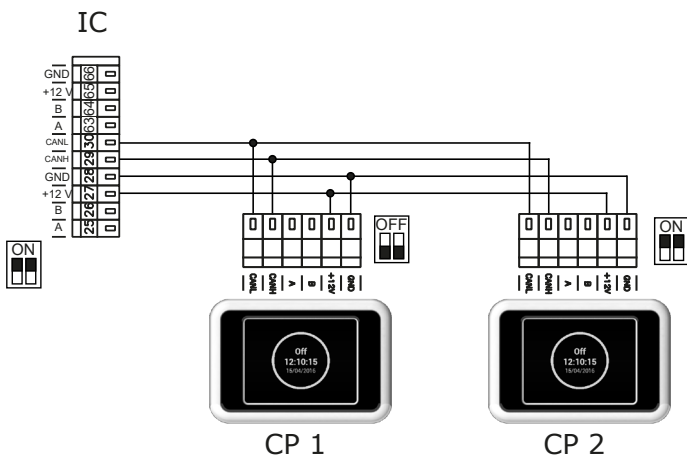

Electrical connection - Option 2:

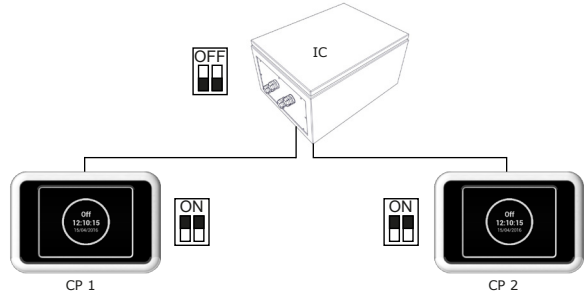

Electrical connection - Option 2:

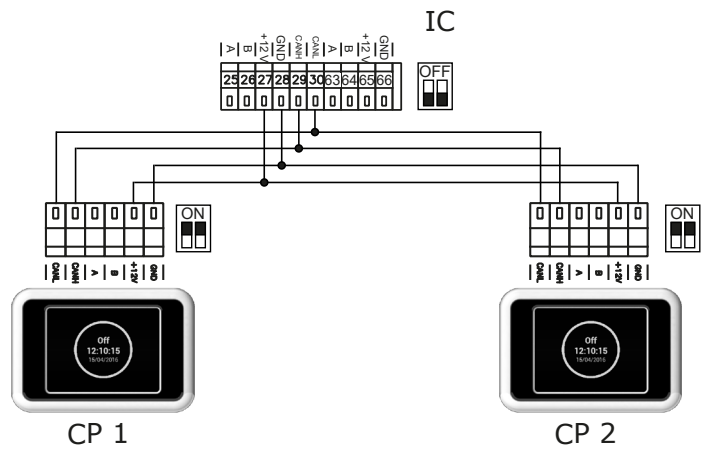

## MENU - FACTORY RESET

This regulator settings MENU to default settings



Pressing the "FACTORY RESET" button sets values in MENU 1616 to the outgoing



After completion it is recommended that you deactivate and connect the main power supply of the regulator

## 8. MAINTENANCE

We recommend checking the regulator and cleaning it once every six months, however the exact intervals should be adapted to operating conditions. We recommend thoroughly cleaning the regulator once per year.

You can clean the regulator using a vacuum cleaner, brush, cloth and soap water (only from the outside; observe processes and requirements for handling electrical devices).

Do not use sharp objects, aggressive chemicals, solvents, abrasive cleaners, pressurized water jets, compressed air, or steam when cleaning the regulator.

## 9. TROUBLESHOOTING

Description	Device behavior	Likely problem	Solution
44 - Fan error	Device not working	Overheated fan or thermal contact error of the intake fan	Determine the cause of the motor overheating (defective bearing, mechanical defect, short, etc.) or replace the motor. Check the connection of thermo contacts from the motor to the regulator.
45 - Required maintenance/fouled filter	Device working	Filter or set replacement time has been reached	Replace filter. After replacing filter, don't forget to RESET in MENU 1616 - FILTER TIMER
46 - Heater failure	Device not working	Heater defect	Check the heater and the status of the safety thermostat. Is proper cooling of the heater secured? Check motor operation.
47 - Exterior temperature sensor failure (45,46)	Device not working	Defective temperature sensor on connectors 45,46	Check proper connection of sensor to electronics, if applicable test sensor functionality using resistance measurement (resistance value at +20°C is approx. 10kΩ)
48 - Exhaust air temperature sensor failure (49,50)	Device not working	Defective temperature sensor on connectors 49,50	Check proper connection of sensor to electronics, if applicable test sensor functionality using resistance measurement (resistance value at +20°C is approx. 10kΩ)
49 - Intake air temperature sensor failure (51,52)	Device not working	Defective temperature sensor on connectors 51,52	Check proper connection of sensor to electronics, if applicable test sensor functionality using resistance measurement (resistance value at +20°C is approx. 10kΩ)
60 - Recirculated heat exchanger water sensor failure (53,54)	Device not working	Defective temperature sensor on connectors 53,54	Check proper connection of sensor to electronics, if applicable test sensor functionality using resistance measurement (resistance value at +20°C is approx. 10kΩ)
61 - Spatial temperature sensor failure (55,56)	Device not working	Defective temperature sensor on connectors 55,56	Check proper connection of sensor to electronics, if applicable test sensor functionality using resistance measurement (resistance value at +20°C is approx. 10kΩ)

Description	Device behavior	Likely problem	Solution
62 - Exterior temperature sensor error from BMS	Device working with limitations	Defective temperature sensor in BMS	Check the proper setting of address in BMS where the given sensor is sending its data (to the correct regulator). Check proper sensor functioning in BMS
63 - Spatial temperature sensor error from BMS	Device working with limitations	Defective temperature sensor in BMS	Check the proper setting of address in BMS where the given sensor is sending its data (to the correct regulator). Check proper sensor functioning in BMS
64 - Air throughput detection sensor failure	Device not working	The regulator is not receiving information about air throughput	Check the connection, or proper functioning of the air throughput detector.
52 - Maintenance deadline approaching/ Fouled filter > 80%	Device working	Fouled filter has exceeded 80% of set time	Recommended inspection of filter status and replacement of filter if applicable. After replacing filter, don't forget to RESET in MENU 1616 - FILTER TIMER
79 - Heating degraded. Due to low air throughput.	Device working	Solely informational status	A change of requirement for lower air power has occurred and has automatically resulted in limiting heater performance for preventing overheating.
65 - Communications error	Device not working	Communications error	Check whether the communications cable is properly connected and is not damaged. Respect the connection schematic and limit phenomena that could disrupt communications (cables in the vicinity of high voltage, phenomena at the site of installation that could cause disruption)

# 10. SPARE PARTS

## SC-C/S-AC

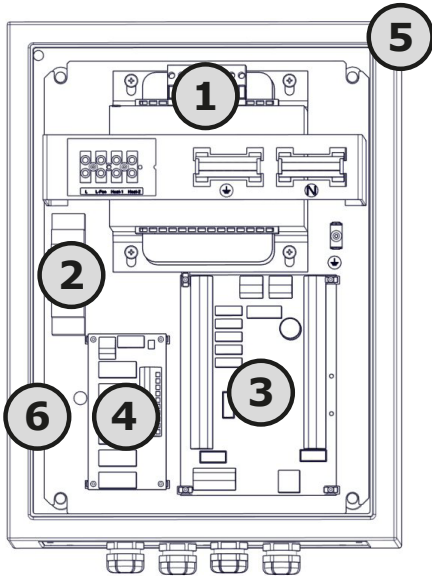

Designation	Description
1	Transformer (4A / 7A / 16A)
2	Power supply
3	PCB module A/B
4	PCB module AC
5	Box
6	Auxiliary SSR (only with version 16A)

## SC-C/S-EC

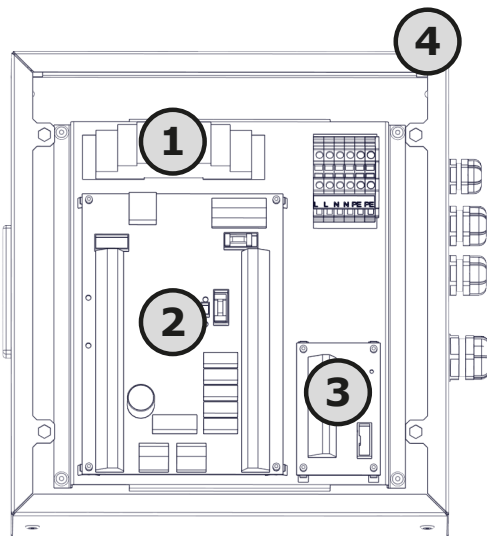

Designation	Description
1	Power supply
2	PCB module A/B
3	PCB module TACHO
4	Box

# 11. WARING DIAGRAM



## SC-C-AC5-04/07

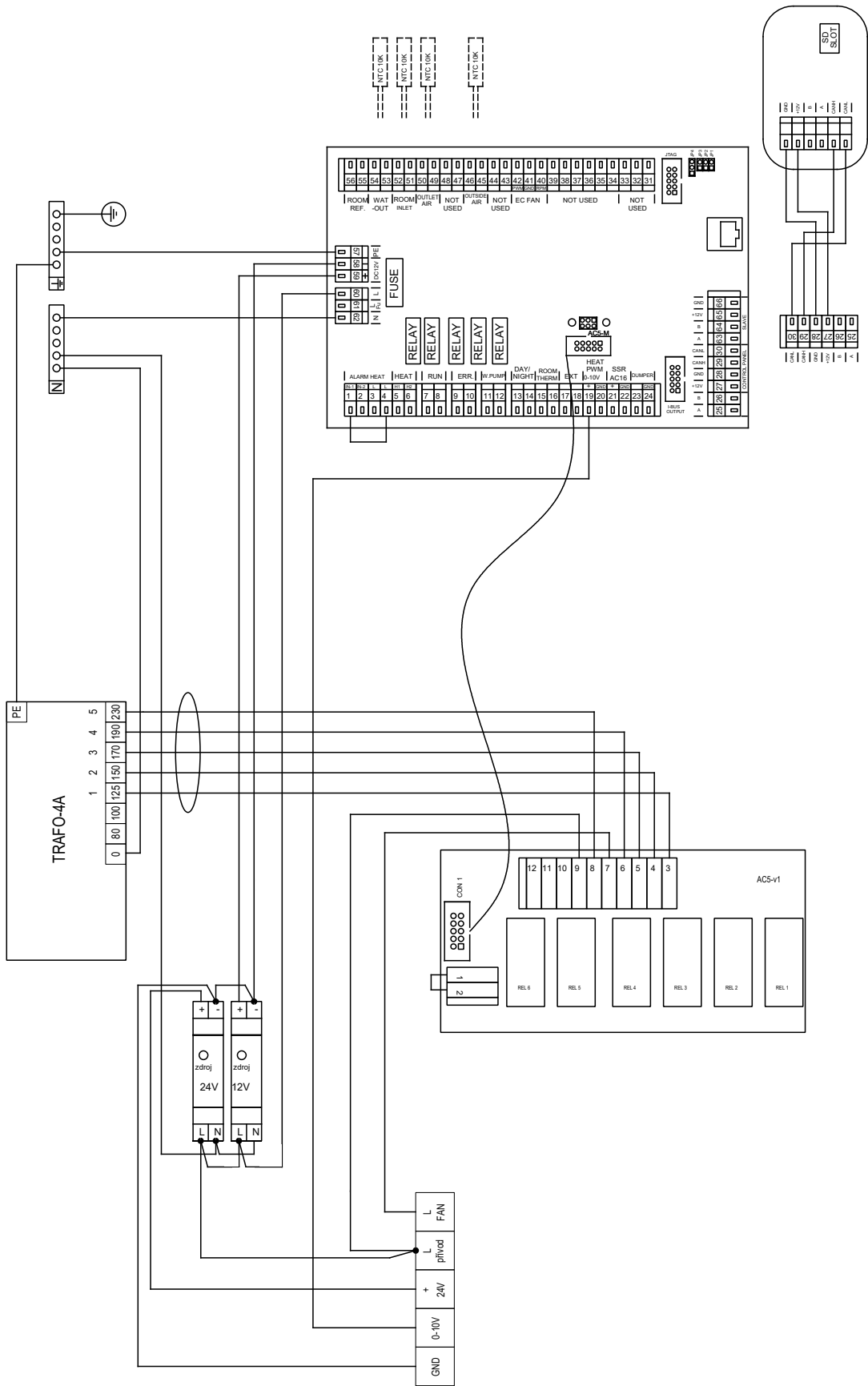

# 11. WARING DIAGRAM



## SC-S-AC5-04/07

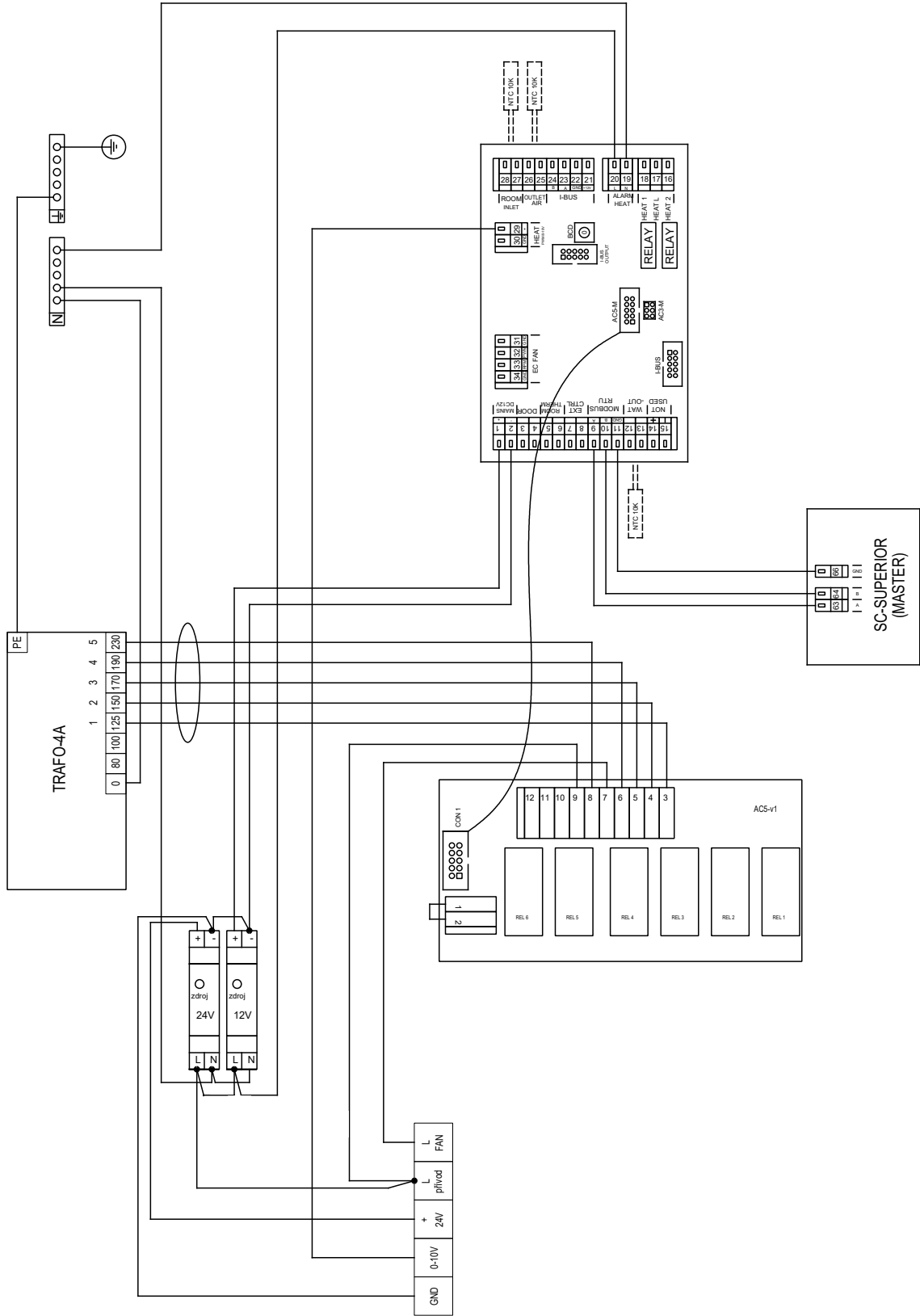

# 11. WARING DIAGRAM

## SC-C-AC5-16

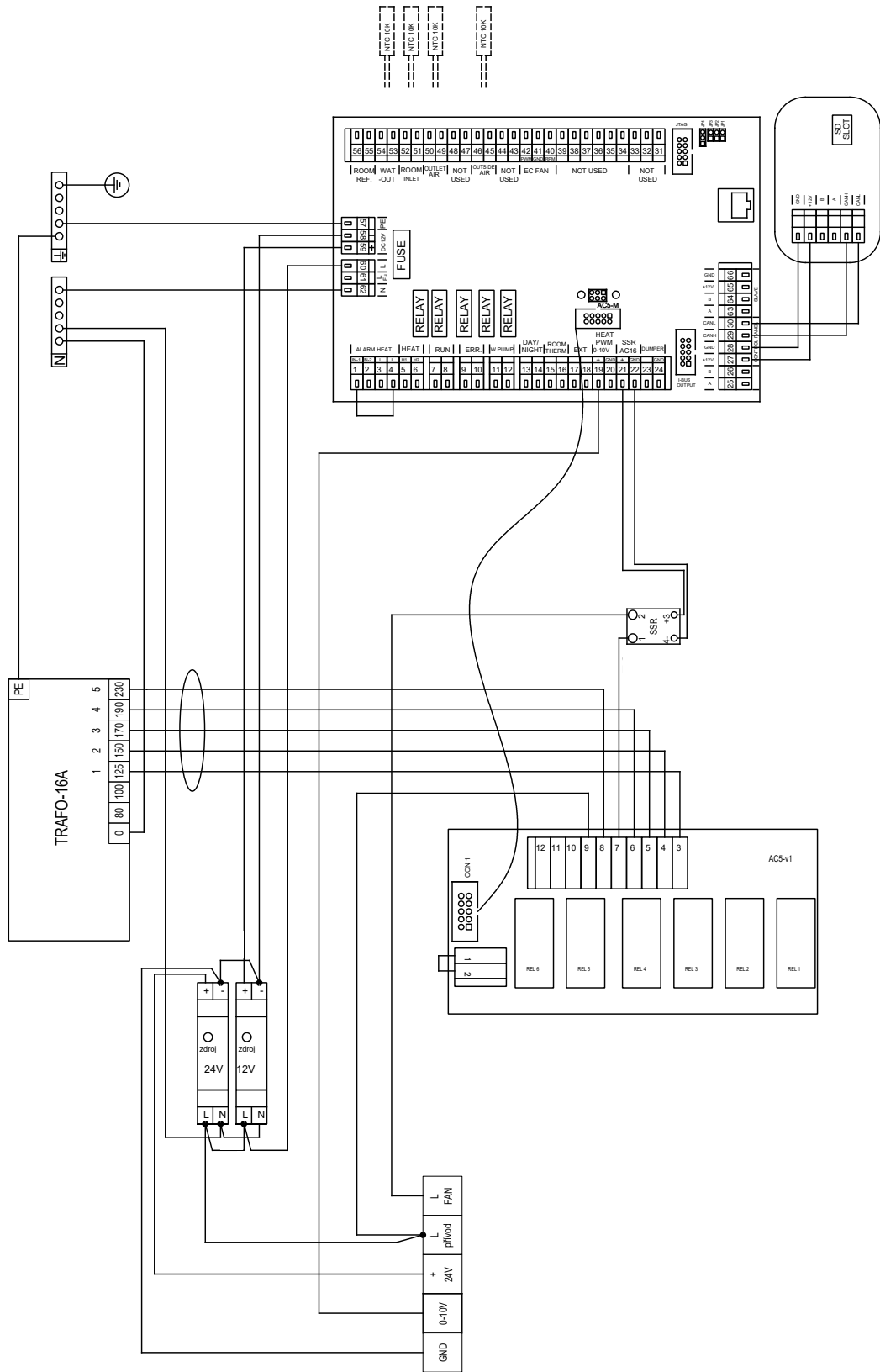

# 11. WARING DIAGRAM

## SC-S-AC5-16

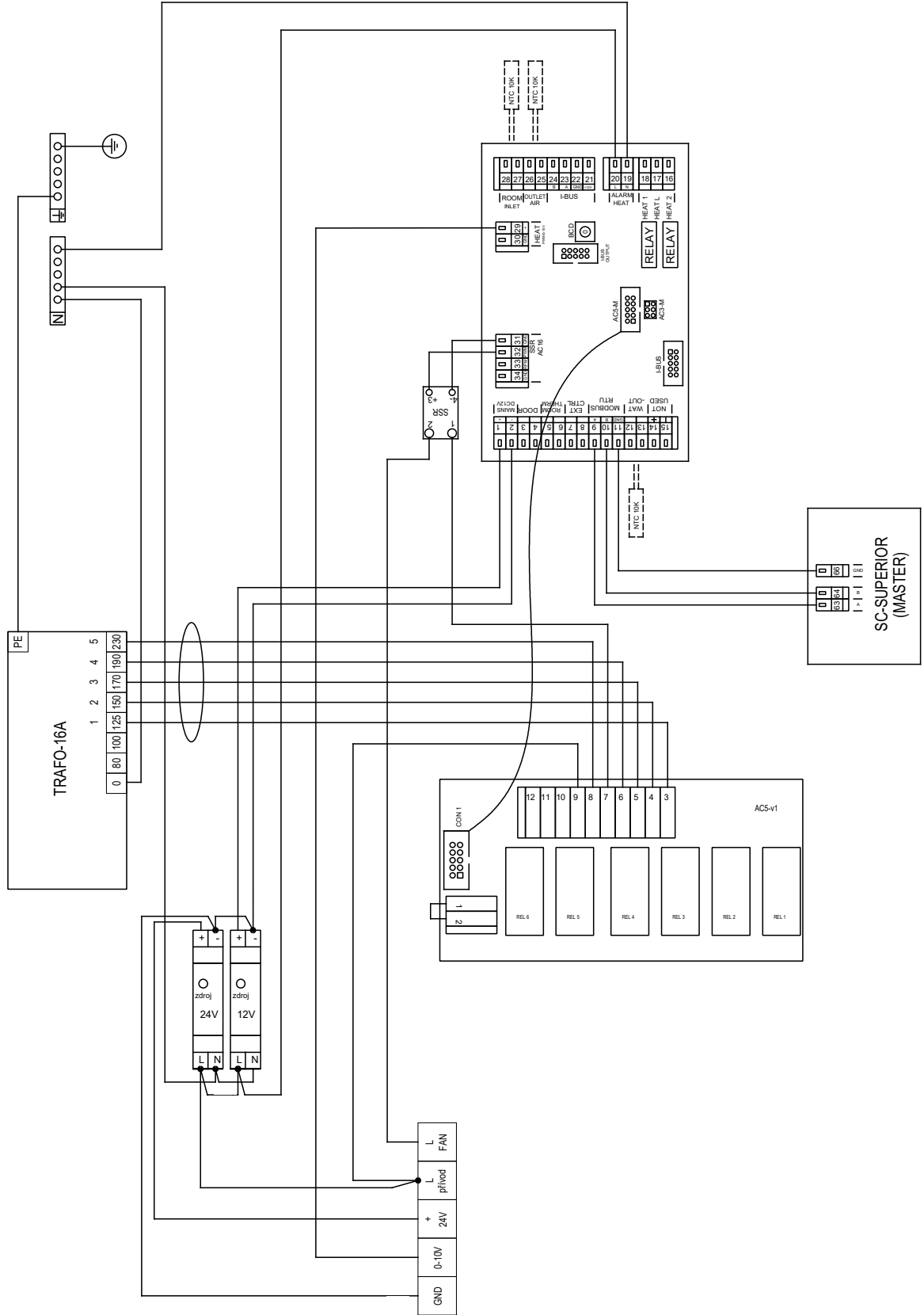





## 12. CONCLUSION



For proper and safe use of the regulation unit, it is necessary to properly read this guide and follow the instructions.

For any question or request for explanation, do not hesitate to contact our sales department or technical support.

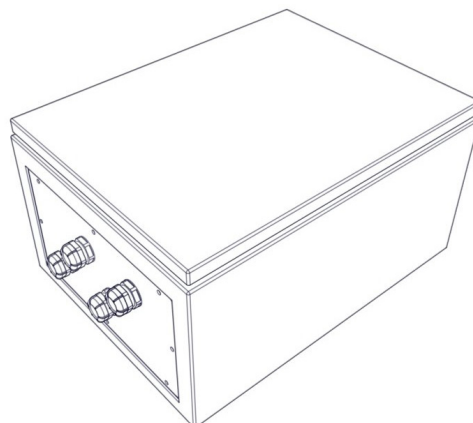
**Contact:**

2VV, s.r.o.,  
Fáblovka 568,  
533 52 Pardubice,  
Česká republika

**Internet:**

<http://www.2vv.cz>



Copyright © 2VV  
All rights reserved.

**The manufacturer shall not be held liable for any damages caused to the device due to unqualified installation and operation in conflict with this guide and common practice for installation and operation of HVAC units and regulation systems**