



air-only



water heater



electric wire heater



BASIC FEATURES

- **EC version airflow** up to **6.400 m³/h** (ISO 27 327-1)
- **AC version airflow** up to **5.090 m³/h** (ISO 27 327-1)
- Length: **1,0; 1,5; 2,0** and **2,5m**
- Integrated **AirGENIO control**

STANDESSE air curtain is an elegant air curtain delivering confident, high-performance operation. Its refined and attractive design makes it an ideal solution for representative commercial interiors such as banks, luxury boutiques, shopping centres, airports, and administrative buildings. Designed for exposed installation, it is recommended for entrance doors with installation heights of up to 5 m*.

**Maximum recommended installation height – may vary according the particular conditions at the installation site.*

The air curtain has a self-supporting casing made of galvanized metal sheet, powder-coated in RAL9016 colour with a glossy smooth finish; any RAL colour may be provided upon the customer's request.

The air curtain is equipped with a centrifugal fans, available with either a **3-speed AC** motors or an **energy-efficient EC** motors controlled via PWM. The fan motors incorporate maintenance-free ball bearings and thermal protection for enhanced durability. For heating options, the air curtain can be fitted with an **LPHW coil** or **electric wire heater**. Its exhaust nozzle is equipped with **adjustable aluminium lamellas**, allowing precise airflow direction against the door opening.

An integrated control system ensures efficient operation. Two control options are available:

- **AirGENIO BASIC** simple power control
- **AirGENIO PRIME** – an advanced control system that optimizes operation for interior comfort while minimizing energy costs.

The air curtain shall be installed indoors in a dry environment, with ambient temperatures ranging from **0 °C up to +40 °C** and relative humidity of up to 80%. It is designed to convey air free of fine dust, grease, chemical fumes, and other impurities. The IP rating of the air curtain is **IP20**. To ensure optimal performance, it is recommended that air curtain projects be developed by an HVAC designer or engineer.



PRIMARY PARAMETERS

Air curtains with electric heater are fitted with automatic heat thermostat and emergency thermostat with manual reset. Air curtains with LPHW coil are designed for the maximum operating water temperature of +100 °C and maximum operating pressure of 1.6 MPa.

VCST5 AC

Type	Recommended installation height [m]	Air output [m ³ /h] ^{*1}			Acoustic pressure at 3m[dB(A)] ^{*2}			Sound power [dB(A)] ^{*3}
		Speed 3	Speed 2	Speed 1	Speed 3	Speed 2	Speed 1	
VCST5B100-S0AC	4,0	1626	1182	813	56	48	40	74
VCST5B150-S0AC		2513	1774	1256	59	51	43	76
VCST5B200-S0AC		3362	2328	1626	60	52	44	77
VCST5B250-S0AC		4065	2956	2106	61	53	45	78
VCST5B100-E1AC		1589	1145	813	56	48	40	74
VCST5B150-E1AC		2476	1700	1219	59	51	43	76
VCST5B200-E1AC		3362	2291	1589	60	52	44	77
VCST5B250-E1AC		3991	2919	2069	61	53	45	78
VCST5B100-V2AC		1552	1109	776	56	48	40	73
VCST5B150-V2AC		2439	1663	1182	58	49	42	75
VCST5B200-V2AC		3252	2180	1552	59	51	43	77
VCST5B250-V2AC		3880	2734	1884	61	53	45	78
VCST5C100-S0AC		5,0	2303	1656	1172	60	52	44
VCST5C150-S0AC	3353		2424	1737	60	52	44	78
VCST5C200-S0AC	4161		2990	2101	60	53	45	78
VCST5C250-S0AC	5090		3636	2666	61	53	46	79
VCST5C100-E1AC	2262		1616	1131	60	52	44	77
VCST5C150-E1AC	3272		2384	1697	60	52	44	78
VCST5C200-E1AC	4080		2949	2060	60	53	45	78
VCST5C250-E1AC	4888		3555	2586	61	53	46	79
VCST5C100-V2AC	2222		1576	1115	59	51	43	77
VCST5C150-V2AC	3151		2182	1616	60	52	44	77
VCST5C200-V2AC	3878		2788	1939	60	53	45	78
VCST5C250-V2AC	4808		3434	2424	61	53	46	78
VCST5C100-V3AC	2038		1364	1020	59	51	43	77
VCST5C150-V3AC	2838		1983	1469	60	52	44	77
VCST5C200-V3AC	3493		2534	1763	60	53	45	78
VCST5C250-V3AC	4331		3121	2203	61	53	46	78

VCST5 EC

Type	Recommended installation height [m]	Air output [m³/h] **					Acoustic pressure at 3 m [dB(A)] ²					Sound power [dB(A)] ³
		100%	80%	60%	40%	20%	100%	80%	60%	40%	20%	
VCST5B100-S0EC	4,0	1900	1750	1600	1350	950	53	52	50	47	42	75
VCST5B150-S0EC		2800	2650	2380	2000	1450	54	53	50	47	38	76
VCST5B200-S0EC		3800	3570	3200	2750	1950	56	55	52	48	40	78
VCST5B250-S0EC		4700	4470	4000	3400	2400	58	56	53	50	41	80
VCST5B100-E1EC		1900	1750	1600	1350	950	53	52	50	47	42	75
VCST5B150-E1EC		2800	2650	2380	2000	1450	54	53	50	47	38	76
VCST5B200-E1EC		3800	3570	3200	2750	1950	56	55	52	48	40	78
VCST5B250-E1EC		4700	4470	4000	3400	2400	58	56	53	50	41	80
VCST5B100-V2EC		1850	1700	1550	1300	900	53	51	50	47	42	74
VCST5B150-V2EC		2700	2500	2270	1920	1400	55	53	51	47	38	76
VCST5B200-V2EC		3700	3470	3140	2650	1900	56	54	52	48	40	77
VCST5B250-V2EC		4500	4200	3800	3200	2330	57	55	53	49	40	79
VCST5C100-S0EC	5,0	2550	2400	2150	1800	1270	56	54	51	47	39	77
VCST5C150-S0EC		3650	3400	3100	2600	1850	57	55	54	50	43	78
VCST5C200-S0EC		4650	4350	3900	3300	2400	58	57	54	51	46	80
VCST5C250-S0EC		6400	6000	5350	4500	3150	59	57	55	51	42	81
VCST5C100-E1EC		2550	2400	2150	1800	1270	56	54	51	47	39	77
VCST5C150-E1EC		3650	3400	3100	2600	1850	57	55	54	50	43	78
VCST5C200-E1EC		4650	4350	3900	3300	2400	58	57	54	51	46	80
VCST5C250-E1EC		6400	6000	5350	4500	3150	59	57	55	51	42	81
VCST5C100-V2EC		2450	2300	2050	1750	1200	57	56	55	53	42	78
VCST5C150-V2EC		3500	3250	2900	2400	1800	57	56	54	51	43	78
VCST5C200-V2EC		4550	4150	3700	3150	2250	58	56	54	51	46	79
VCST5C250-V2EC		5900	5500	4950	4200	2850	58	56	54	50	42	80
VCST5C100-V3EC		2400	2250	2000	1750	1200	56	56	55	53	42	77
VCST5C150-V3EC		3450	3200	2900	2400	1750	57	56	54	51	43	78
VCST5C200-V3EC		4450	4100	3650	3100	2200	58	56	54	51	46	79
VCST5C250-V3EC		5850	5450	4900	4150	2800	58	56	54	50	42	80

**1 Airflow volume according ISO27327-1

**2 Acoustic pressure values at 3 m distance for maximum speed. Directional factor: Q=2.

**3 Sound power (LWA) measurements according to ISO 27327-2.

VCST5 AC

Type	Heater power output [kW]		Total power input [kW] ^{*1}	Total voltage/ current [V/A]	Motor voltage/ current [V/A]	Temperature increase Δt [°C]	Frequency [Hz]	Weight [kg] ^{*4}
	1st level	2st level						
VCST5B100-S0AC	-	-	0,65	230/2,85	230/2,85	-	50	44
VCST5B150-S0AC	-	-	1,00	230/4,4	230/4,4	-	50	61
VCST5B200-S0AC	-	-	1,30	230/5,7	230/5,7	-	50	78
VCST5B250-S0AC	-	-	1,60	230/7,0	230/7,0	-	50	95
VCST5B100-E1AC	4,6	9,4	10,30	400/16,6	230/2,85	17,8*	50	48,5
VCST5B150-E1AC	7,6	15,0	16,00	400/26,1	230/4,4	18,05*	50	66
VCST5B200-E1AC	9,8	19,0	20,30	400/33,2	230/5,7	16,84*	50	84
VCST5B250-E1AC	12,5	24,5	26,10	400/42	230/7,0	18,3*	50	102
VCST5B100-V2AC	-	-	0,65	230/2,85	230/2,85	39,5 * ²	50	50
VCST5B150-V2AC	-	-	1,00	230/4,4	230/4,4	40,6 * ²	50	67
VCST5B200-V2AC	-	-	1,30	230/5,7	230/5,7	41,5 * ²	50	85
VCST5B250-V2AC	-	-	1,60	230/7,0	230/7,0	42 * ²	50	99
VCST5C100-S0AC	-	-	0,95	230/4,0	230/4,0	-	50	48
VCST5C150-S0AC	-	-	1,35	230/5,6	230/5,6	-	50	64
VCST5C200-S0AC	-	-	1,70	230/7,0	230/7,0	-	50	80
VCST5C250-S0AC	-	-	2,00	230/8,7	230/8,7	-	50	98
VCST5C100-E1AC	4,6	9,9	10,60	400/17,6	230/4,0	12,5 *	50	53
VCST5C150-E1AC	7,6	15,0	17,00	400/27,5	230/7,0	13,66 *	50	68
VCST5C200-E1AC	9,8	19,0	20,80	400/34,2	230/8,7	13,88 *	50	86
VCST5C250-E1AC	12,5	24,5	26,50	400/44	230/6,9	14,94 *	50	110
VCST5C100-V2AC	-	-	0,95	230/4,0	230/4,0	35,1 * ²	50	55
VCST5C150-V2AC	-	-	1,35	230/5,6	230/5,6	37,3 * ²	50	70
VCST5C200-V2AC	-	-	1,70	230/7,0	230/7,0	39,3 * ²	50	88
VCST5C250-V2AC	-	-	2,00	230/8,7	230/8,7	40,8 * ²	50	108
VCST5C100-V3AC	-	-	0,95	230/4,00	230/4,00	12,6 * ³	50	85
VCST5C150-V3AC	-	-	1,35	230/5,60	230/5,60	13,9 * ³	50	72
VCST5C200-V3AC	-	-	1,70	230/7,00	230/7,00	14,0 * ³	50	90
VCST5C250-V3AC	-	-	2,00	230/8,70	230/8,70	13,9 * ³	50	110

* At the maximum air flow and maximum heater power.

^{*2} Intake air temperature +18°C, water temperature gradient of 90/70 °C and highest fan speed.

^{*3} Intake air temperature +18°C, water temperature gradient of 40/30 °C and highest fan speed.

^{*4} Weight with control BASIC / PRIME.

VCST5 EC

Type	Heater power output [kW]		Total power input [kW] ^{*1}	Total voltage/ current [V/A]	Motor voltage/ current [V/A]	Temperature increase Δt [°C]	Frequency [Hz]	Weight [kg]
	1st level	2nd level						
VCST5B100-S0EC	-	-	0,34	230/2,4	230/2,4	-	50/60	40
VCST5B150-S0EC	-	-	0,50	230/3,4	230/3,4	-	50/60	55
VCST5B200-S0EC	-	-	0,68	230/4,4	230/4,4	-	50/60	70
VCST5B250-S0EC	-	-	0,85	230/5,4	230/5,4	-	50/60	85
VCST5B100-E1EC	4,6	9,4	9,74	400/16,0	230/2,4	14,7	50/60	45
VCST5B150-E1EC	7,6	15,0	15,50	400/25,1	230/3,4	16,0	50/60	60
VCST5B200-E1EC	9,8	19,0	19,68	400/31,9	230/4,4	14,9	50/60	76
VCST5B250-E1EC	12,5	24,5	25,35	400/40,8	230/5,4	15,5	50/60	92
VCST5B100-V2EC	-	-	0,34	230/2,4	230/2,4	38,6 ^{*2}	50/60	46
VCST5B150-V2EC	-	-	0,50	230/3,4	230/3,4	38,5 ^{*2}	50/60	61
VCST5B200-V2EC	-	-	0,68	230/4,4	230/4,4	39,6 ^{*2}	50/60	77
VCST5B250-V2EC	-	-	0,85	230/5,4	230/5,4	40,1 ^{*2}	50/60	89
VCST5C100-S0EC	-	-	0,50	230/3,3	230/3,3	-	50/60	44
VCST5C150-S0EC	-	-	0,68	230/4,5	230/4,5	-	50/60	59
VCST5C200-S0EC	-	-	0,84	230/5,3	230/5,3	-	50/60	73
VCST5C250-S0EC	-	-	1,20	230/7,2	230/7,2	-	50/60	91
VCST5C100-E1EC	4,6	9,9	9,90	400/16,9	230/3,3	11,6	50/60	50
VCST5C150-E1EC	7,6	15,0	15,68	400/21,2	230/4,5	12,3	50/60	64
VCST5C200-E1EC	9,8	19,0	19,84	400/32,8	230/5,3	10,0	50/60	80
VCST5C250-E1EC	12,5	24,5	25,70	400/42,6	230/7,2	11,4	50/60	104
VCST5C100-V2EC	-	-	0,50	230/3,3	230/3,3	34,5 ^{*2}	50/60	51
VCST5C150-V2EC	-	-	0,68	230/4,5	230/4,5	34,7 ^{*2}	50/60	65
VCST5C200-V2EC	-	-	0,84	230/5,3	230/5,3	36,9 ^{*2}	50/60	81
VCST5C250-V2EC	-	-	1,20	230/7,2	230/7,2	36,1 ^{*2}	50/60	101
VCST5C100-V3EC	-	-	0,50	230/3,3	230/3,3	12,0 ^{*2}	50/60	53
VCST5C150-V3EC	-	-	0,68	230/4,5	230/4,5	12,9 ^{*3}	50/60	69
VCST5C200-V3EC	-	-	0,84	230/5,3	230/5,3	13,2 ^{*3}	50/60	85
VCST5C250-V3EC	-	-	1,20	230/7,2	230/8,7	13,1 ^{*3}	50/60	104

* At the maximum air flow and maximum heater power.

*² Intake air temperature +18°C, water temperature gradient of 90/70 °C and highest fan speed.

*³ Intake air temperature +18°C, water temperature gradient of 40/30 °C and highest fan speed.

*⁴ Weight with control BASIC / PRIME.

LPHW coil parameters for water temperature gradient of 90/70 °C

*Temperature of intake air: +18 °C

VCST5 AC

Type	Air output	Heat output	Temperature at exhaust	Pressure loss	Water flow
	[m³/h]	[kW]	[°C]	[kPa]	[l/s]
VCST5B100-V2AC	1552	21,6	59,2	6,7	0,27
VCST5B150-V2AC	2439	32,9	57,9	4,9	0,41
VCST5B200-V2AC	3252	45,5	59,5	10,0	0,56
VCST5B250-V2AC	3880	55,5	60,3	15,4	0,68
VCST5C100-V2AC	2222	26,9	53,9	10,1	0,33
VCST5C150-V2AC	3151	38,5	54,2	6,6	0,47
VCST5C200-V2AC	3878	50,9	56,9	12,3	0,63
VCST5C250-V2AC	4808	63,6	57,2	19,9	0,78

VCST5 EC

Type	Air output	Heat output	Temperature at exhaust	Pressure loss	Water flow
	[m³/h]	[kW]	[°C]	[kPa]	[l/s]
VCST5B100-V2EC	1850	24,1	56,6	8,2	0,30
VCST5B150-V2EC	2700	35,1	56,5	5,5	0,43
VCST5B200-V2EC	3700	49,4	57,6	11,6	0,61
VCST5B250-V2EC	4500	61	58,1	18,4	0,75
VCST5C100-V2EC	2450	28,5	52,5	11,3	0,35
VCST5C150-V2EC	3500	41,0	52,7	7,5	0,51
VCST5C200-V2EC	4450	55,8	54,7	14,6	0,69
VCST5C250-V2EC	5900	72,0	54,1	25,3	0,89

LPHW coil parameters for water temperature gradient of 80/60 °C

*Temperature of intake air: +18 °C

VCST5 AC

Type	Air output	Heat output	Temperature at exhaust	Pressure loss	Water flow
	[m³/h]	[kW]	[°C]	[kPa]	[l/s]
VCST5B100-V2AC	1552	17,7	51,7	4,7	0,22
VCST5B150-V2AC	2439	26,7	50,5	3,3	0,33
VCST5B200-V2AC	3252	37,4	52,0	6,9	0,46
VCST5B250-V2AC	3880	45,7	52,9	10,8	0,56
VCST5C100-V2AC	2222	22,0	47,3	7,0	0,27
VCST5C150-V2AC	3151	31,2	47,4	4,5	0,38
VCST5C200-V2AC	3878	41,7	49,8	8,5	0,51
VCST5C250-V2AC	4808	52,3	50,2	13,9	0,64

VCST5 EC

Type	Air output	Heat output	Temperature at exhaust	Pressure loss	Water flow
	[m³/h]	[kW]	[°C]	[kPa]	[l/s]
VCST5B100-V2EC	1850	19,7	49,5	5,7	0,24
VCST5B150-V2EC	2700	28,5	49,2	3,8	0,35
VCST5B200-V2EC	3700	40,5	50,4	8,1	0,50
VCST5B250-V2EC	4500	50,2	51,0	12,9	0,62
VCST5C100-V2EC	2450	23,3	46,1	7,8	0,29
VCST5C150-V2EC	3500	33,2	46,1	5,0	0,41
VCST5C200-V2EC	4450	45,6	48,0	10,1	0,56
VCST5C250-V2EC	5900	59,1	47,7	17,6	0,73

LPHW coil parameters for water temperature gradient of 70/50 °C

*Temperature of intake air: +18 °C

VCST5 AC

Type	Air output	Heat output	Temperature at exhaust	Pressure loss	Water flow
	[m³/h]	[kW]	[°C]	[kPa]	[l/s]
VCST5B100-V2AC	1552	13,7	44,2	3,0	0,17
VCST5B150-V2AC	2439	20,5	42,9	2,0	0,50
VCST5B200-V2AC	3252	29,1	44,5	4,4	0,36
VCST5B250-V2AC	3880	35,9	45,4	6,9	0,44
VCST5C100-V2AC	2222	17,0	40,6	4,4	0,21
VCST5C150-V2AC	3151	23,9	40,4	2,7	0,33
VCST5C200-V2AC	3878	32,4	42,7	5,3	0,39
VCST5C250-V2AC	4808	40,9	43,2	8,9	0,50

VCST5 EC

Type	Air output	Heat output	Temperature at exhaust	Pressure loss	Water flow
	[m³/h]	[kW]	[°C]	[kPa]	[l/s]
VCST5B100-V2EC	1850	15,3	42,4	3,6	0,19
VCST5B150-V2EC	2700	21,8	41,9	2,3	0,27
VCST5B200-V2EC	3700	31,5	43,2	5,1	0,38
VCST5B250-V2EC	4500	39,3	43,9	8,2	0,48
VCST5C100-V2EC	2450	18,0	39,7	4,9	0,22
VCST5C150-V2EC	3500	25,4	39,5	3,1	0,31
VCST5C200-V2EC	4450	35,3	41,3	6,3	0,43
VCST5C250-V2EC	5900	46,1	41,2	11,1	0,56

LPHW coil parameters for water temperature gradient of 60/40 °C

*Temperature of intake air: +18 °C

VCST5 AC

Type	Air output	Heat output	Temperature at exhaust	Pressure loss	Water flow
	[m³/h]	[kW]	[°C]	[kPa]	[l/s]
VCST5B100-V2AC	1552	9,7	36,6	1,6	0,12
VCST5B150-V2AC	2439	14,1	35,1	1,0	0,17
VCST5B200-V2AC	3252	20,7	36,9	2,3	0,25
VCST5B250-V2AC	3880	25,9	37,7	3,8	0,31
VCST5C100-V2AC	2222	12,0	33,9	2,3	0,14
VCST5C150-V2AC	3151	16,4	33,4	1,4	0,20
VCST5C200-V2AC	3878	23,0	35,5	2,8	0,28
VCST5C250-V2AC	4808	29,3	36,1	4,8	0,36

VCST5 EC

Type	Air output	Heat output	Temperature at exhaust	Pressure loss	Water flow
	[m³/h]	[kW]	[°C]	[kPa]	[l/s]
VCST5B100-V2EC	1850	10,8	35,2	1,9	0,13
VCST5B150-V2EC	2700	15,1	34,5	1,2	0,18
VCST5B200-V2EC	3700	22,3	35,9	2,7	0,27
VCST5B250-V2EC	4500	28,2	36,6	4,5	0,34
VCST5C100-V2EC	2450	12,6	33,2	2,6	0,15
VCST5C150-V2EC	3500	17,4	32,7	1,5	0,21
VCST5C200-V2EC	4450	25,0	34,4	3,3	0,30
VCST5C250-V2EC	5900	32,9	34,5	6,0	0,40

LPHW coil parameters for water temperature gradient 50/30 °C

*Temperature of intake air: +18 °C

VCST5 AC

Type	Air output	Heat output	Temperature at exhaust	Pressure loss	Water flow
	[m³/h]	[kW]	[°C]	[kPa]	[l/s]
VCST5C100-V3AC	2038	10,4	32,9	2,6	0,12
VCST5C150-V3AC	2838	15,5	34,0	5,9	0,19
VCST5C200-V3AC	3493	19,4	34,4	5,0	0,23
VCST5C250-V3AC	4331	24,8	34,8	8,8	0,30

VCST5 EC

Type	Air output	Heat output	Temperature at exhaust	Pressure loss	Water flow
	[m³/h]	[kW]	[°C]	[kPa]	[l/s]
VCST5C100-V3EC	2400	11,4	32,1	2,9	0,14
VCST5C150-V3EC	3450	18,2	33,6	5,6	0,22
VCST5C200-V3EC	4450	24,0	33,9	5,9	0,29
VCST5C250-V3EC	5850	31,8	34,1	11,0	0,38

LPHW coil parameters for water temperature gradient 40/30 °C

*Temperature of intake air: +18 °C

VCST5 AC

Type	Air output	Heat output	Temperature at exhaust	Pressure loss	Water flow
	[m³/h]	[kW]	[°C]	[kPa]	[l/s]
VCST5C100-V3AC	2038	8,9	30,6	7	0,22
VCST5C150-V3AC	2838	12,8	31,3	14,7	0,31
VCST5C200-V3AC	3493	16,1	31,6	12,5	0,39
VCST5C250-V3AC	4331	20,2	31,7	21,4	0,49

VCST5 EC

Type	Air output	Heat output	Temperature at exhaust	Pressure loss	Water flow
	[m³/h]	[kW]	[°C]	[kPa]	[l/s]
VCST5C100-V3EC	2400	9,7	30,0	7,8	0,24
VCST5C150-V3EC	3450	15,0	30,9	14,4	0,36
VCST5C200-V3EC	4450	19,8	31,2	15,1	0,48
VCST5C250-V3EC	5850	25,9	31,1	27,6	0,63

LPHW coil parameters for water temperature gradient 35/25 °C

*Temperature of intake air: +18 °C

VCST5 AC

Type	Air output	Heat output	Temperature at exhaust	Pressure loss	Water flow
	[m³/h]	[kW]	[°C]	[kPa]	[l/s]
VCST5C100-V3AC	2038	5,6	26,1	3,2	0,14
VCST5C150-V3AC	2838	8,4	26,7	7,2	0,20
VCST5C200-V3AC	3493	10,5	26,9	6,0	0,25
VCST5C250-V3AC	4331	13,5	27,2	10,6	0,32

VCST5 EC

Type	Air output	Heat output	Temperature at exhaust	Pressure loss	Water flow
	[m³/h]	[kW]	[°C]	[kPa]	[l/s]
VCST5C100-V3EC	2400	6,2	25,7	3,5	0,15
VCST5C150-V3EC	3450	9,8	26,4	6,8	0,24
VCST5C200-V3EC	4450	13,0	26,6	7,1	0,31
VCST5C250-V3EC	5850	17,3	26,7	13,3	0,41

Recommended mixing points for LPHW coil 3-way valve

Type	Control module	90/70 °C	80/60 °C	70/50 °C	60/40 °C
		3-way valve			
VCST5B100-V2..	BASIC / PRIME (ON/OFF)	ZV3-230-04,0-20 RT-3-07	ZV3-230-04,0-20 RT-3-07	ZV3-230-04,0-20 RT-3-07	ZV3-230-04,0-20 RT-3-07
	PRIME (0-10V)	ZV3-024-04,0-20	ZV3-024-04,0-20	ZV3-024-04,0-20	ZV3-024-04,0-20
VCST5B150-V2..	BASIC / PRIME (ON/OFF)	ZV3-230-04,0-20 RT-3-07	ZV3-230-04,0-20 RT-3-07	ZV3-230-04,0-20 RT-3-07	ZV3-230-04,0-20 RT-3-07
	PRIME (0-10V)	ZV3-024-04,0-20	ZV3-024-04,0-20	ZV3-024-04,0-20	ZV3-024-04,0-20
VCST5B200-V2..	BASIC / PRIME (ON/OFF)	ZV3-230-21,0-20 RT-3-07	ZV3-230-21,0-20 RT-3-07	ZV3-230-21,0-20 RT-3-07	ZV3-230-21,0-20 RT-3-07
	PRIME (0-10V)	ZV3-024-06,3-20	ZV3-024-06,3-20	ZV3-024-06,3-20	ZV3-024-06,3-20
VCST5B250-V2..	BASIC / PRIME (ON/OFF)	ZV3-230-21,0-20 RT-3-07	ZV3-230-21,0-20 RT-3-07	ZV3-230-21,0-20 RT-3-07	ZV3-230-21,0-20 RT-3-07
	PRIME (0-10V)	ZV3-024-06,3-20	ZV3-024-06,3-20	ZV3-024-06,3-20	ZV3-024-06,3-20
VCST5C100-V2EC	BASIC / PRIME (ON/OFF)	ZV3-230-04,0-20 RT-3-07	ZV3-230-04,0-20 RT-3-07	ZV3-230-04,0-20 RT-3-07	ZV3-230-04,0-20 RT-3-07
	PRIME (0-10V)	ZV3-024-04,0-20	ZV3-024-04,0-20	ZV3-024-04,0-20	ZV3-024-04,0-20
VCST5C150-V2EC	BASIC / PRIME (ON/OFF)	ZV3-230-04,0-20 RT-3-07	ZV3-230-04,0-20 RT-3-07	ZV3-230-04,0-20 RT-3-07	ZV3-230-04,0-20 RT-3-07
	PRIME (0-10V)	ZV3-024-04,0-20	ZV3-024-04,0-20	ZV3-024-04,0-20	ZV3-024-04,0-20
VCST5C200-V2EC	BASIC / PRIME (ON/OFF)	ZV3-230-21,0-20 RT-3-07	ZV3-230-21,0-20 RT-3-07	ZV3-230-21,0-20 RT-3-07	ZV3-230-21,0-20 RT-3-07
	PRIME (0-10V)	ZV3-024-06,3-20	ZV3-024-06,3-20	ZV3-024-06,3-20	ZV3-024-06,3-20
VCST5C250-V2EC	BASIC / PRIME (ON/OFF)	ZV3-230-21,0-20 RT-3-07	ZV3-230-21,0-20 RT-3-07	ZV3-230-21,0-20 RT-3-07	ZV3-230-21,0-20 RT-3-07
	PRIME (0-10V)	ZV3-024-06,3-20	ZV3-024-06,3-20	ZV3-024-06,3-20	ZV3-024-06,3-20

Type	Control module	40/30 °C	35/25 °C
		3-way valve	
VCST5C100-V3EC	BASIC / PRIME (ON/OFF)	ZV3-230-04,0-20 RT-3-07	ZV3-230-04,0-20 RT-3-07
	PRIME (0-10V)	ZV3-024-04,0-20	ZV3-024-04,0-20
VCST5C150-V3EC	BASIC / PRIME (ON/OFF)	ZV3-230-04,0-20 RT-3-07	ZV3-230-04,0-20 RT-3-07
	PRIME (0-10V)	ZV3-024-04,0-20	ZV3-024-04,0-20
VCST5C200-V3EC	BASIC / PRIME (ON/OFF)	ZV3-230-04,0-20 RT-3-07	ZV3-230-04,0-20 RT-3-07
	PRIME (0-10V)	ZV3-024-06,3-20	ZV3-024-06,3-20
VCST5C250-V3EC	BASIC / PRIME (ON/OFF)	ZV3-230-21,0-20 RT-3-07	ZV3-230-04,0-20 RT-3-07
	PRIME (0-10V)	ZV3-024-06,3-20	ZV3-024-06,3-20

Recommended mixing points for LPHW coil 2-way valve

Type	Control module	90/70 °C	80/60 °C	70/50 °C	60/40 °C
		2-way valve			
VCST5B100-V2..	BASIC / PRIME (ON/OFF)	ZV2-230-08,0-20	ZV2-230-08,0-20	ZV2-230-08,0-20	ZV2-230-08,0-20
	PRIME (0-10V)	ZV2-024-08,0-20	ZV2-024-08,0-20	ZV2-024-08,0-20	ZV2-024-08,0-20
VCST5B150-V2..	BASIC / PRIME (ON/OFF)	ZV2-230-08,0-20	ZV2-230-08,0-20	ZV2-230-08,0-20	ZV2-230-08,0-20
	PRIME (0-10V)	ZV2-024-08,0-20	ZV2-024-08,0-20	ZV2-024-08,0-20	ZV2-024-08,0-20
VCST5B200-V2..	BASIC / PRIME (ON/OFF)	ZV2-230-08,0-20	ZV2-230-08,0-20	ZV2-230-08,0-20	ZV2-230-08,0-20
	PRIME (0-10V)	ZV2-024-08,0-20	ZV2-024-08,0-20	ZV2-024-08,0-20	ZV2-024-08,0-20
VCST5B250-V2..	BASIC / PRIME (ON/OFF)	ZV2-230-08,0-20	ZV2-230-08,0-20	ZV2-230-08,0-20	ZV2-230-08,0-20
	PRIME (0-10V)	ZV2-024-08,0-20	ZV2-024-08,0-20	ZV2-024-08,0-20	ZV2-024-08,0-20
VCST5C100-V2EC	BASIC / PRIME (ON/OFF)	ZV2-230-08,0-20	ZV2-230-08,0-20	ZV2-230-08,0-20	ZV2-230-08,0-20
	PRIME (0-10V)	ZV2-024-08,0-20	ZV2-024-08,0-20	ZV2-024-08,0-20	ZV2-024-08,0-20
VCST5C150-V2EC	BASIC / PRIME (ON/OFF)	ZV2-230-08,0-20	ZV2-230-08,0-20	ZV2-230-08,0-20	ZV2-230-08,0-20
	PRIME (0-10V)	ZV2-024-08,0-20	ZV2-024-08,0-20	ZV2-024-08,0-20	ZV2-024-08,0-20
VCST5C200-V2EC	BASIC / PRIME (ON/OFF)	ZV2-230-08,0-20	ZV2-230-08,0-20	ZV2-230-08,0-20	ZV2-230-08,0-20
	PRIME (0-10V)	ZV2-024-08,0-20	ZV2-024-08,0-20	ZV2-024-08,0-20	ZV2-024-08,0-20
VCST5C250-V2EC	BASIC / PRIME (ON/OFF)	ZV2-230-08,0-20	ZV2-230-08,0-20	ZV2-230-08,0-20	ZV2-230-08,0-20
	PRIME (0-10V)	ZV2-024-08,0-20	ZV2-024-08,0-20	ZV2-024-08,0-20	ZV2-024-08,0-20

Type	Control module	40/30 °C	35/25 °C
		2-way valve	
VCST5C100-V3EC	BASIC / PRIME (ON/OFF)	ZV2-230-08,0-20	ZV2-230-08,0-20
	PRIME (0-10V)	ZV2-024-08,0-20	ZV2-024-08,0-20
VCST5C150-V3EC	BASIC / PRIME (ON/OFF)	ZV2-230-08,0-20	ZV2-230-08,0-20
	PRIME (0-10V)	ZV2-024-08,0-20	ZV2-024-08,0-20
VCST5C200-V3EC	BASIC / PRIME (ON/OFF)	ZV2-230-08,0-20	ZV2-230-08,0-20
	PRIME (0-10V)	ZV2-024-08,0-20	ZV2-024-08,0-20
VCST5C250-V3EC	BASIC / PRIME (ON/OFF)	ZV2-230-08,0-20	ZV2-230-08,0-20
	PRIME (0-10V)	ZV2-024-08,0-20	ZV2-024-08,0-20

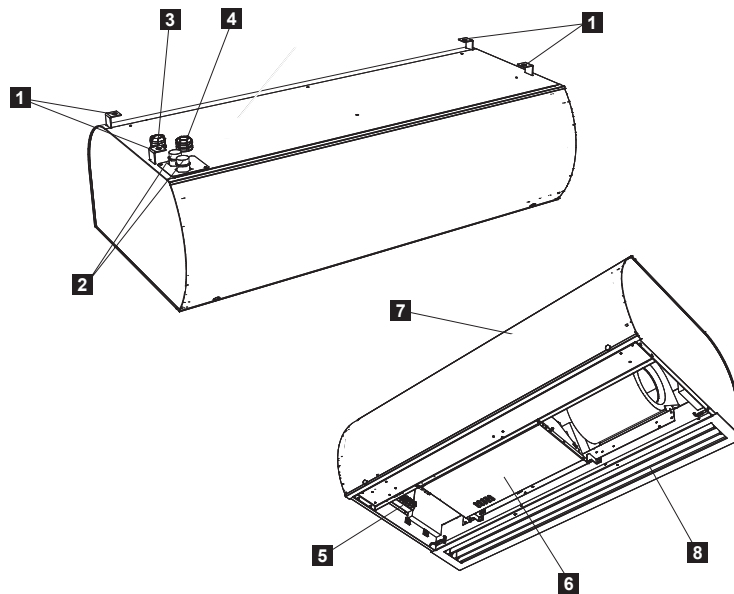

- 1. Suspension holders
- 2. LPHW coil connection 3/4"
- 3. Power supply cable plug
- 4. Control panel cable plug
- 5. Power supply connectors and fusse location
- 6. Control modul socket
- 7. Inlet face cover
- 8. Adjustable lamellas



DIMENSIONS

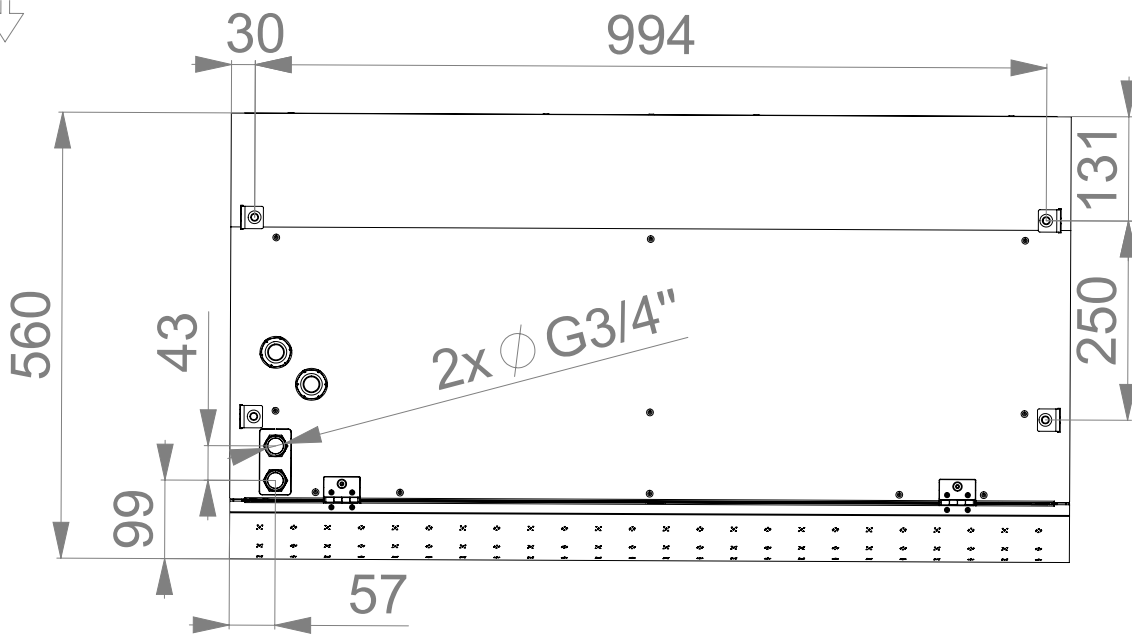

Type	Length [mm]	Width [mm]	Height [mm]
VCST5x100...	994	1054	335
VCST5x150...	1494	1554	
VCST5x-200...	1994	2054	
VCST5x-250...	2394	2454	



INSTALLATION AND ASSEMBLY

- The air curtain shall be installed in a horizontal position only.
- The air curtain shall be located as close to the top edge of the doorway as possible, see figure.
- To ensure a correct function it is recommended that the air curtain overlaps the doorway by 100 mm on both sides.
- Correct operation of the air curtain requires that specified distances from the surrounding objects are observed, see figure.
- Position of the heating water and power supply connections and service access shall be taken into consideration during installation.
- Suspension holders are used for installing the air curtains see ACCESSORIES.
- The air curtain shall be installed separated from flammable materials and safe operation has to be kept.

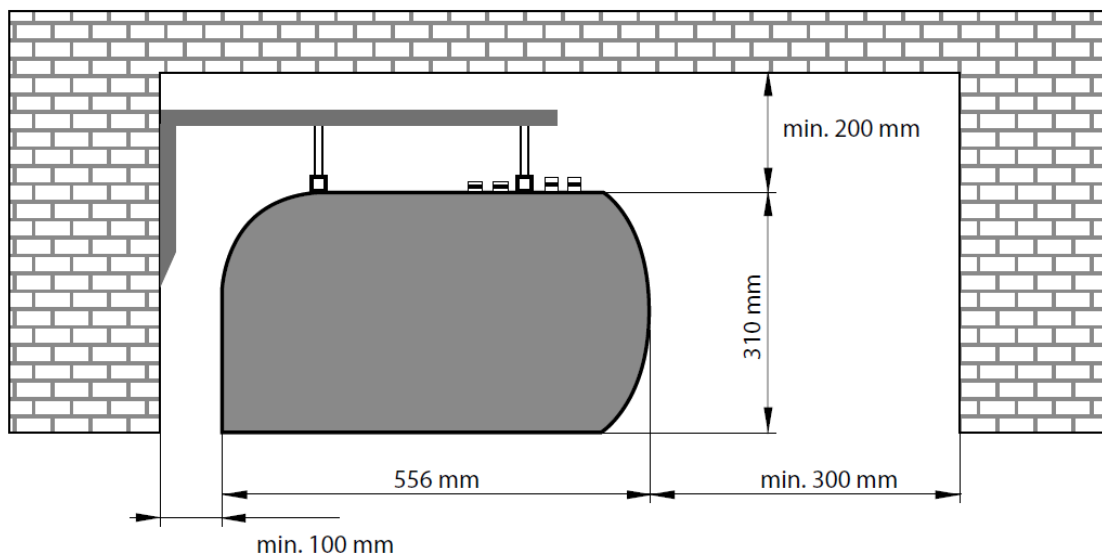

CONTROL

The STANDESSE air curtains are produced with **BASIC** or **PRIME** integration control.
The basic differences among individual control module types are given in table underneath.



CONTROL

Overview of functions and sensor connections

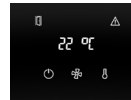

	AirGENIO control	PRIME	BASIC
	Control type	7-segment display with 3 capacity buttons	Manual switch
	Mode	Manual / Auto	Manual
	AC Fan control	AC – 3 steps	AC – 3 steps
	EC Fan control	EC – PWM/0-10V	EC – PWM/0-10V
	Electric heater control	PWM	0 / 50% / 100%
	Water heater control	ON-OFF or 0-10V (settable logic NO/NC)	ON-OFF
	Status indication	Yes (LED on display)	No
	AirGENIO PRIME application	Change of settings	No
	Auto-speed control	Yes	No
	Timer	Yes	No
	Temperature control	Yes (NTC) Built in control panel	No
	DOOR contact connection	Yes Settable logic (NO/NC)	Yes (230V only)
	Summer mode	Yes	No
	Antifreeze protection (LPHW)	Yes (Control by temperature sensor)	No
	Chaining	Yes (max. 10pcs)	No
	ERROR contact	Yes (Jumper setting) / HEAT or RUN+ERROR	No
	RUN contact	Yes (Jumper setting) / HEAT or RUN+ERROR	No
	External control	Yes settable logic (NO/NC)	Yes
	BMS connection	Modbus RTU	No
	Clean intervals	Yes	No



CHAINING EXAMPLE

PRIME

GLOBAL DOOR CONTACT FUNCTION ACTIVE

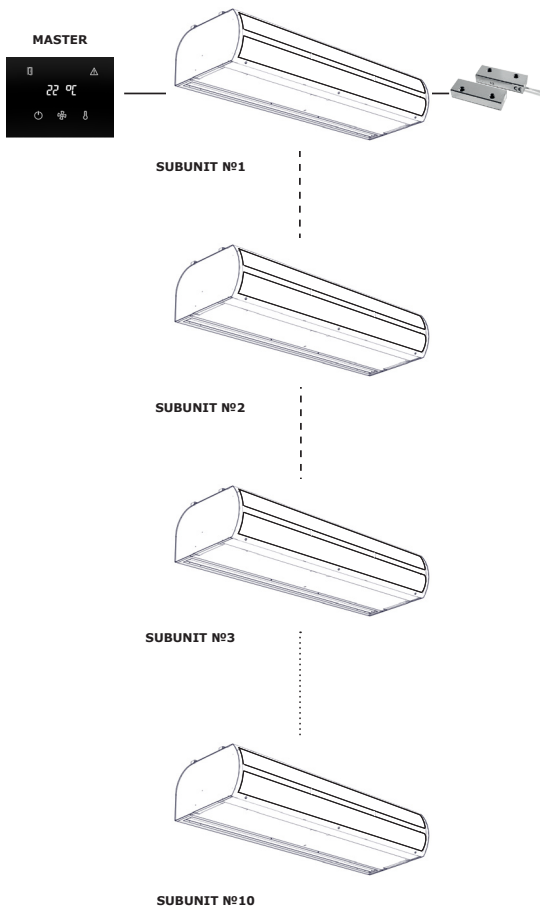

PRIME

GLOBAL DOOR CONTACT FUNCTION NOT ACTIVE

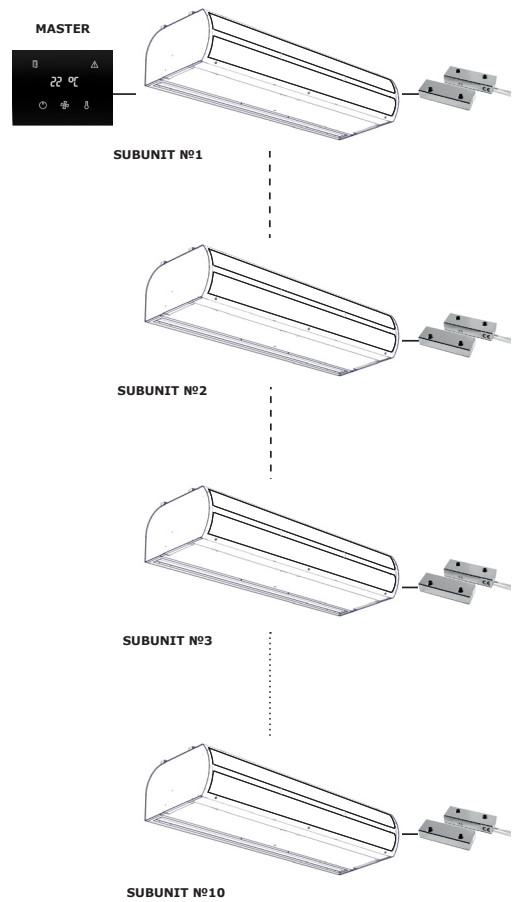



OPTIONAL ACCESSORIES

More details can be found on the relevant page in this catalogue

Thermostatic valve TV-1-1/1
TV-1-1/1



2-way or 3-way valve with servo drive (230V)
ZV2-230-xx,x-xx
ZV3-230-xx,x-xx
(for BASIC and PRIME control)



3-way valve with servo drive RT
RT-3-07 (K_{vs} 07)
(for BASIC and PRIME control)



2-way or 3-way valve with servo drive (0-10V)
ZV2-024-xx,x-xx
ZV3-024-xx,x-xx
(for PRIME control only)



Room thermostat
TER-P



Room temperature sensor for wall installation
CT-ROOM
(for PRIME)



Mechanical industry door switch
DS
Heavy-duty door contact for industry use



Magnetic door contact
DK-B-3
Magnetic door contact in metal housing with higher protection against mechanical damage
(for BASIC EC and PRIME control)



FILTR-VCST5BC-xxx-G1

- 100** - G1 replacement filter for 1.0 m
- 150** - G1 replacement filter for 1.5 m
- 200** - G1 replacement filter for 2.0 m
- 250** - G1 replacement filter for 2.5 m



Wall mounting bracket

Bracket designed for mounting the air curtain to the wall.

- 1 Bracket
- 2 Hanging strip
- 3 Securing screw

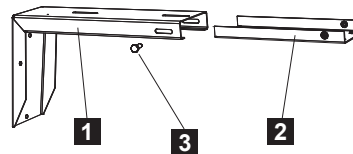

VCS4-KONZ-STE

- for B and C air curtains (2 pcs. in package)
- wall mounting bracket

Ceiling holder

The holder is designed for attaching the air curtain to a ceiling.

- 1 Ceiling bracket
- 2 Hanging strip
- 3 Securing screw

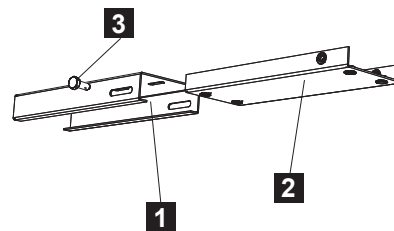

VCS4-KONZ-STR

- for B and C air curtains (2 pcs. in package)
- ceiling holder

Exit sign for marking of emergency exits.

Suitable for all types of air curtains.

VCS4-EXIT



Control panel



KEY TO CODING

CP-CB-AP1-EX-A3

- A3** - AC fans 3 speeds (PRIME control)
- EC** - EC fans (PRIME control)
- EX** - Electric version
- VX** - Water version
- AM** - Ambient - No heating





WIRING DIAGRAMS

The recommended cross-section of the main power supply cables is stated in the Instruction Manual. All wiring diagrams provided in the technical catalog are indicative only. When assembling the product, carefully observe the nameplate ratings as well as directions and diagrams affixed directly to the product or enclosed with the product.



AirGENIO BASIC

BASIC EC

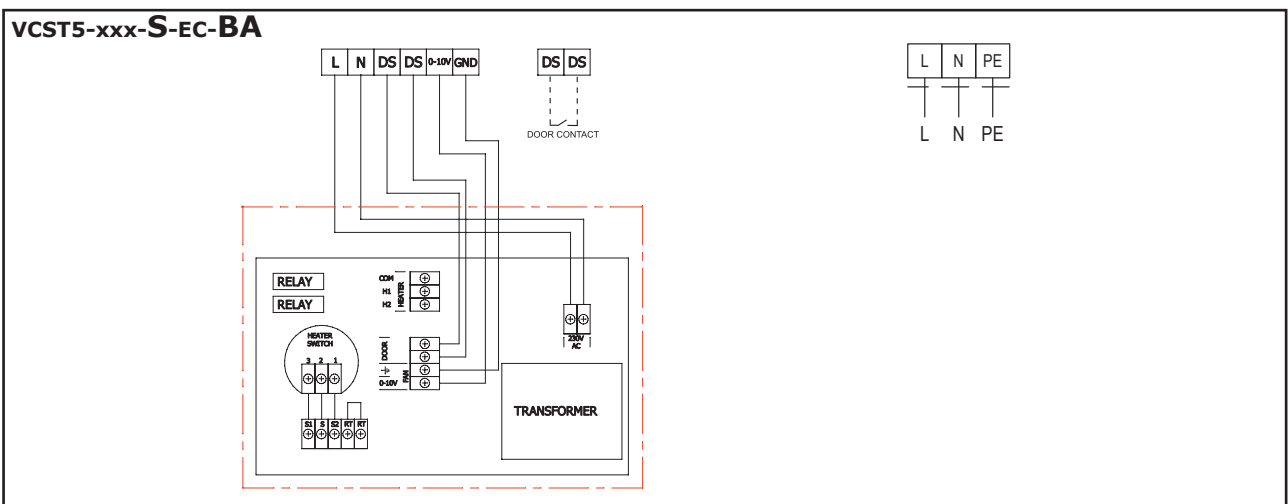
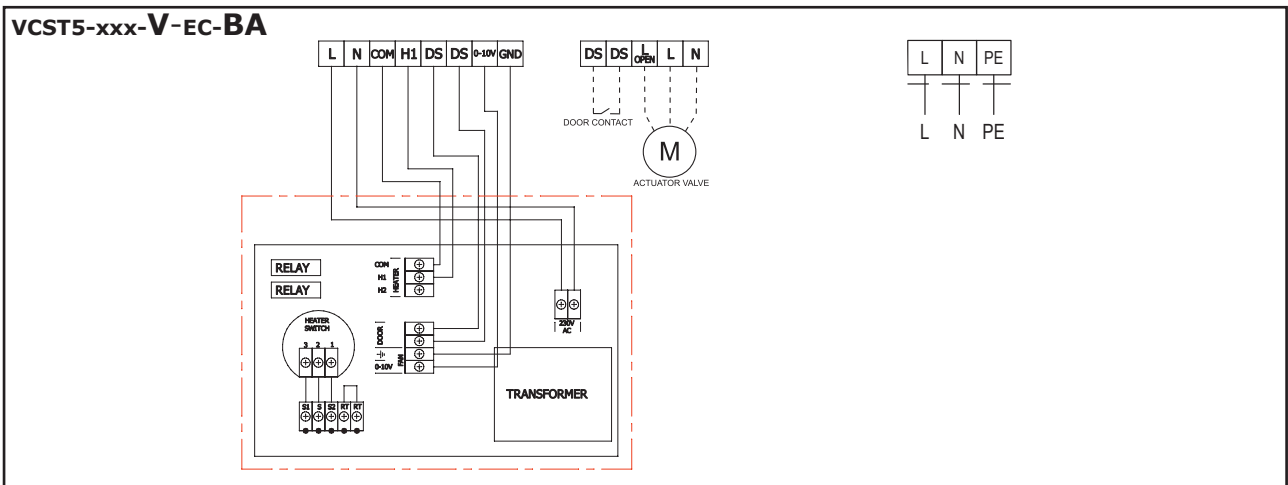
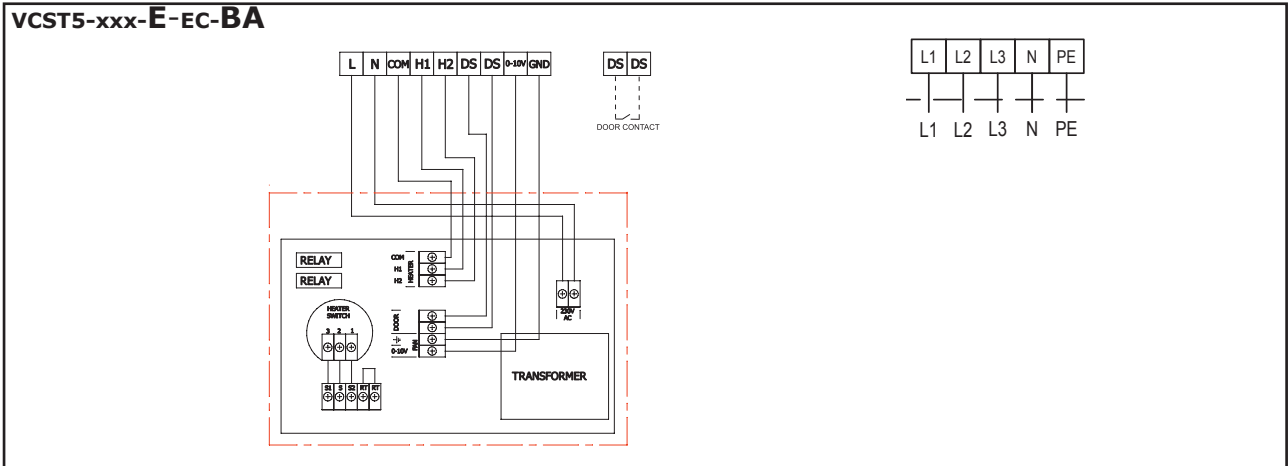



WIRING DIAGRAMS

AirGENIO PRIME AC/EC MASTER

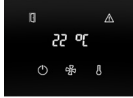

Electric heater	Air-only	Water heater
L1 L2 L3 N PE	L1 N PE	L1 N PE
L1 L2 L3 N PE	L1 N PE	L1 N PE

IN CONTROL MODULE
0-10V +24V GND

10

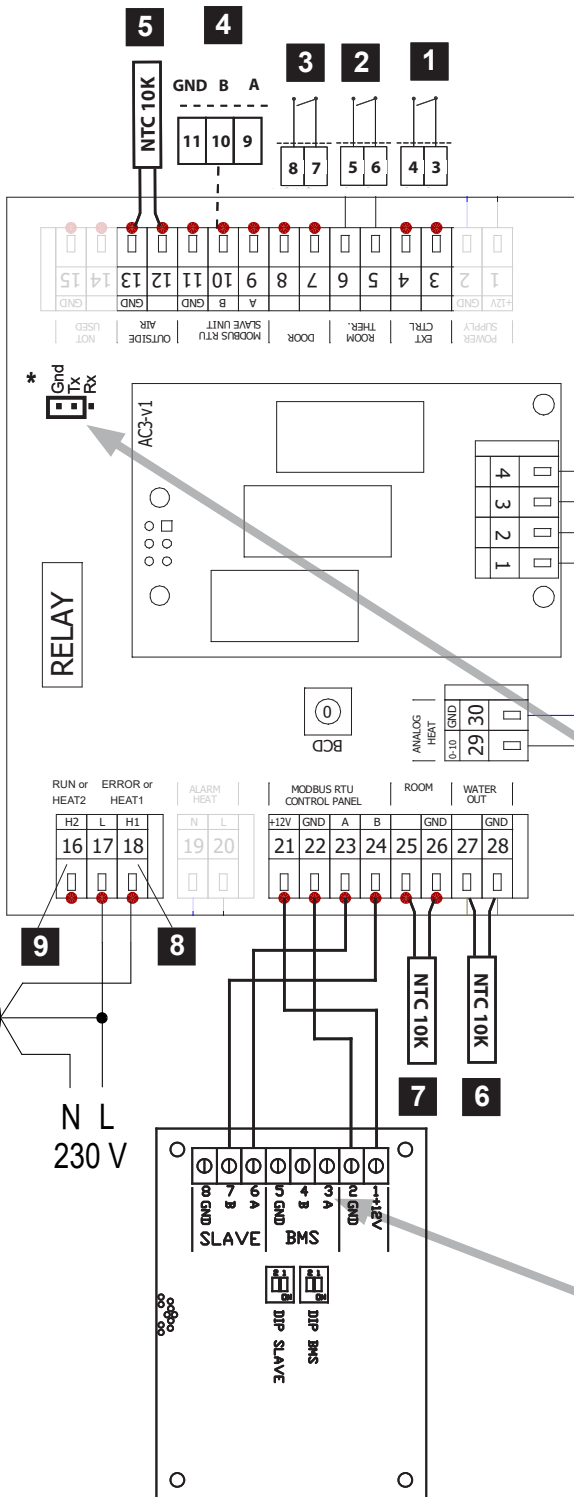

CONTROL PANEL - MASTER

1	External control - (input, ON/OFF)
2	Room Thermostat (input, NO/NC)
3	DOOR contact (input, NO/NC)
4	SLAVE unit connection
5	Outside air sensor (not included in delivery)
6	Antifreeze for water version (included in delivery)
7	Room sensor (not included in delivery)
8	Water valve control ON/OFF or ERROR
9	RUN or HEAT2
10	Water valve control (0-10V)



Water valve control is in default 0-10V

*For NO/OFF water valve control, it is necessary to connect the jumper between GND and Tx



Enable ON/OFF valve and deactivate RUN/ERROR

The default setting from the factory is without the jumper



Enable RUN/ERROR and deactivate ON/OFF valve

Modbus RTU
(A - 3, B - 4, GND - 5)

To connect the controller with the unit control, we recommend using a shielded cable such as UTP CAT5. The maximum recommended cable length is 40m!



WIRING DIAGRAMS

AirGENIO PRIME AC/EC SUBUNITS

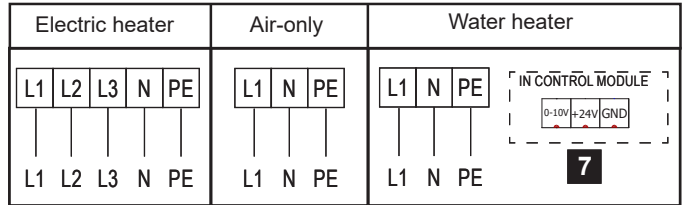
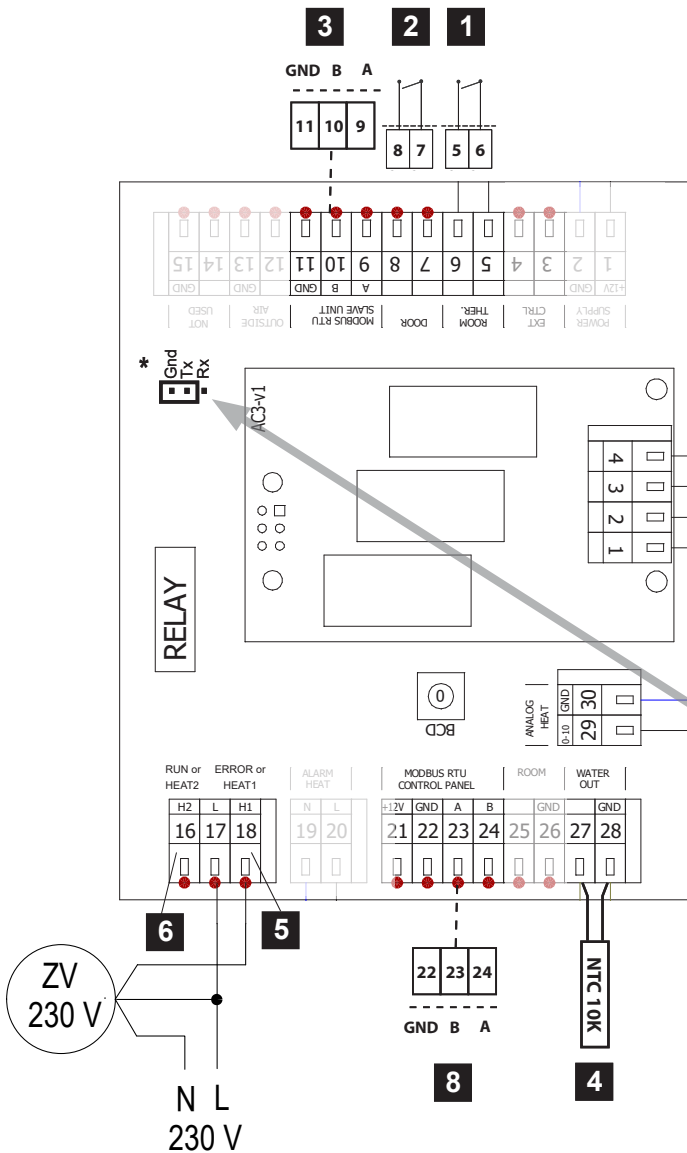

1	Room Thermostat (input, NO/NC)
2	DOOR contact (input, NO/NC)
3	SLAVE unit connection
4	Antifreeze sensor LPHW (included in delivery)
5	Water valve control ON/OFF or ERROR
6	RUN or HEAT2
7	Water valve control (0-10V)
8	MASTER unit connection



Water valve control is in default 0-10V

*For **NO/OFF water valve control**, it is necessary to connect the jumper between GND and Tx



Enable **ON/OFF** valve and deactivate RUN/ERROR

The default setting from the factory is without the jumper



Enable **RUN/ERROR** and deactivate ON/OFF valve



WIRING DIAGRAMS
Chaining

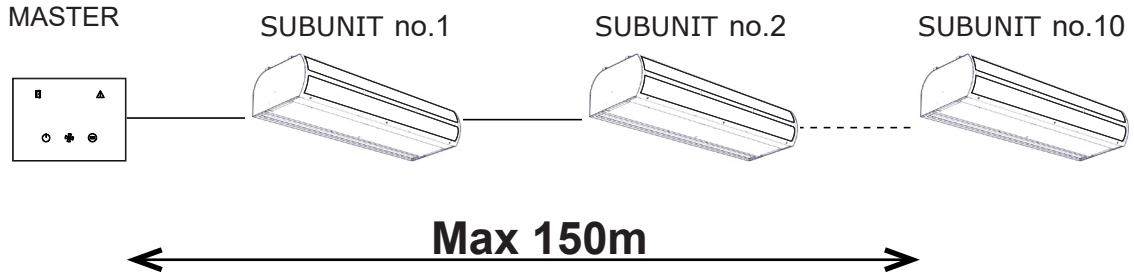

MASTER

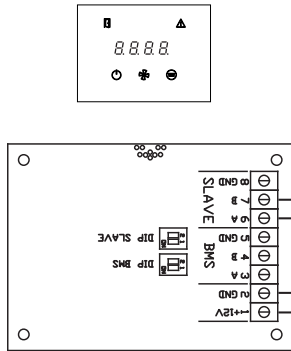

SUBUNIT 1

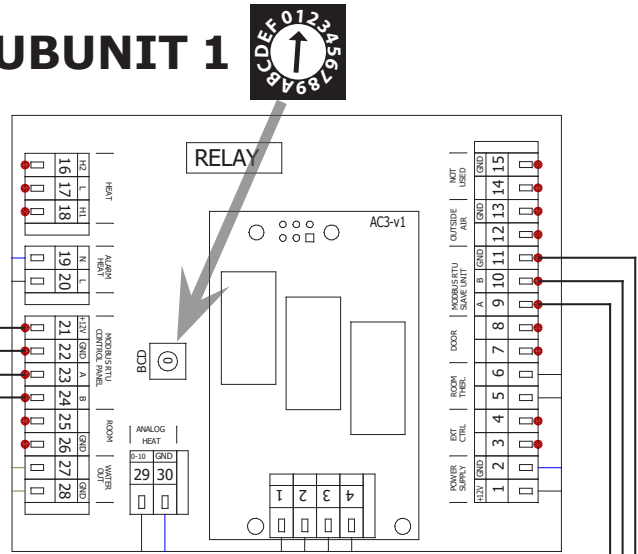

SUBUNIT 2

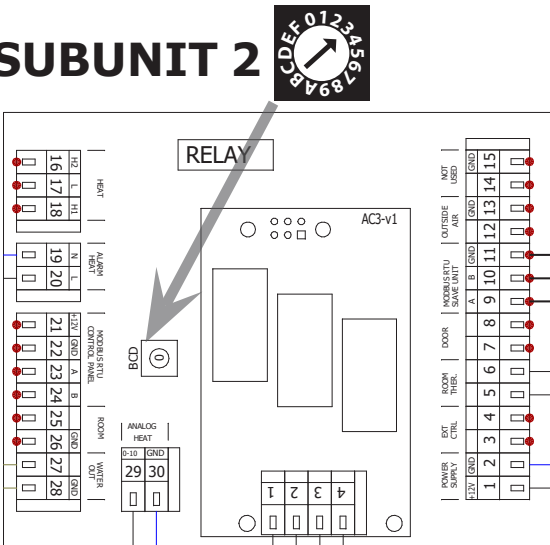

SUBUNIT 3

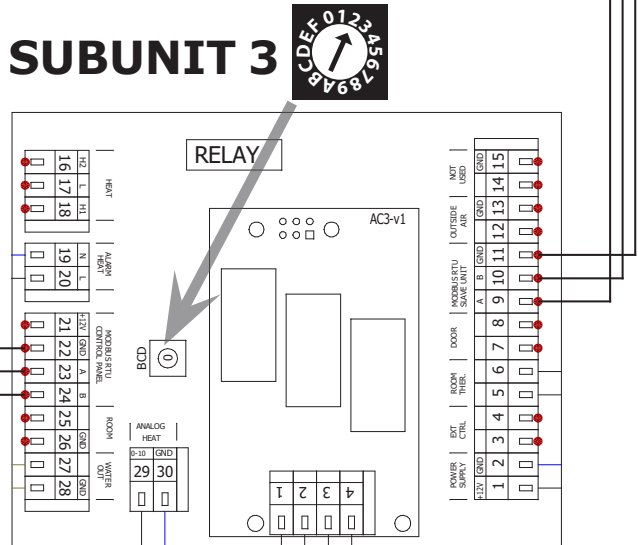



KEY TO CODING

VCST5 B 100 - S0 EC - PR - 0 A0

	A0	2V version
	0	White colour casing RAL 9016 (Standard)
	9	Atyp RAL casing
	PR	PRIME Master (integrated control with control panel)
	PS	PRIME Subunit (integrated control without control panel)
	BA	BASIC control (integrated control with control panel)
	EC	EC fans
	AC	AC fans
	S0	Air-only (ambient)
	E1	Electric heater
	V2	LPHW 2row coil
	V3	LPHW 3row coil (available only for VCST5C)
	100	Nominal width 1000 mm
	150	Nominal width 1500 mm
	200	Nominal width 2000 mm
	250	Nominal width 2500 mm
	B	B Output series
	C	C Output series (EC version only)
	VCST5	STANDESSE air curtain (5th generation)