

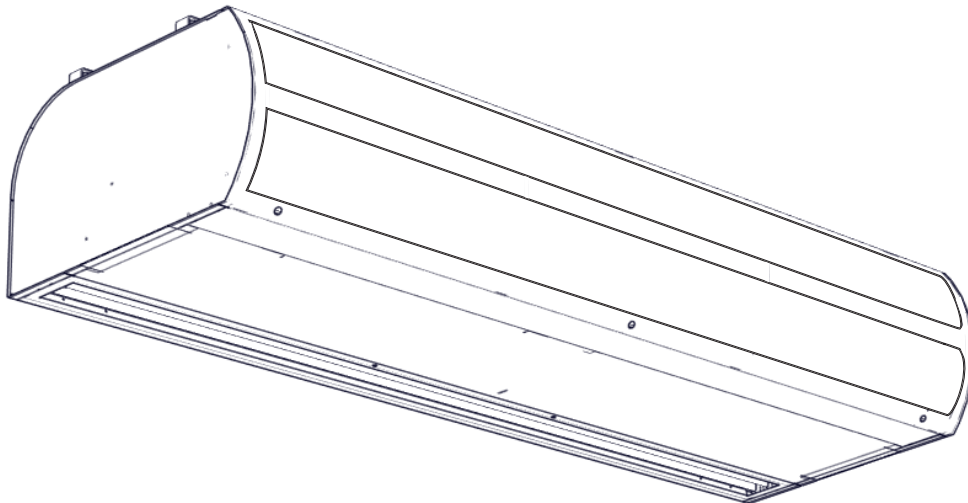

PARTNER
IN VENTILATION
2VV.CZ

EN

STANDESSE AC/EC (VCST5-B/C) BASIC



INSTALLATION AND OPERATION

1. BEFORE YOU BEGIN

Meaning of symbols in the manual:

SYMBOL	MEANING
ATTENTION!	Warning or notice
READ CAREFULLY!	Important instructions
YOU WILL NEED	Practical tips and information
TECHNICAL INFORMATION	Detailed technical information
	Reference to another point/section of the manual



Before installing, read carefully the section **Safe use of the air curtains**, where you will find all the instructions for the safe and proper use of the product.

This manual includes important instructions for the appropriate installation of the air curtains. Before installing, read carefully all the following instructions and observe them. The manufacturer reserves the right to change, including the technical documentation, without prior notice. Keep the manual for future use. The instructions herein are part of the product

Declaration of conformity

Details can be found at www.2vv.cz/en/

2. UNPACKING

2.1 CHECK THE SHIPMENT

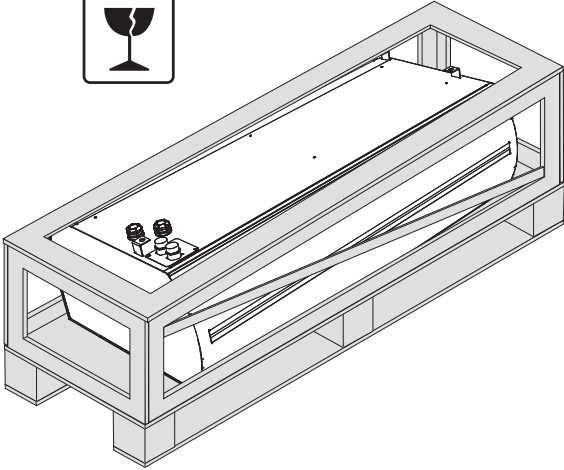

- After delivery, immediately check to see if the packaged product is damaged. If the packaging is damaged contact the delivery service. If the complaint is not filed in time, your claim may not be valid later.
- Check to see if it is the same product you ordered. If there are any discrepancies, do not unpack the curtain, and immediately report the defect to the supplier.
- After unpacking, check to see if the curtain and other parts are in order. If you have any doubts, contact the supplier.
- Never install a damaged air curtain!
- If you do not unpack the curtain immediately after delivery, it must be stored in a dry indoor environment with an ambient temperature between **+5 °C and +40 °C**

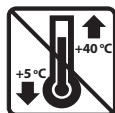
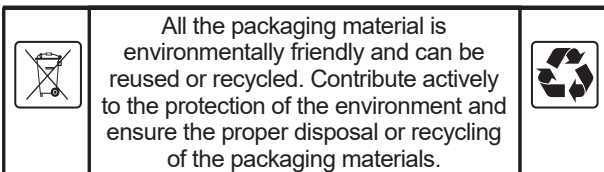

2.2 CONTENTS

1x

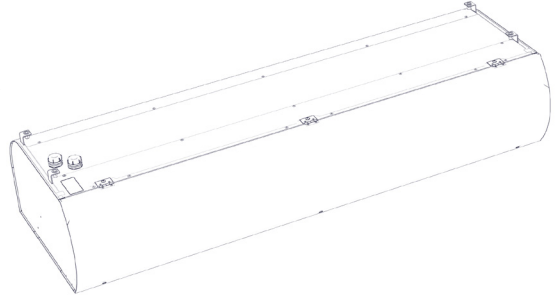

1x



1x

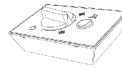

3. MAIN PARTS

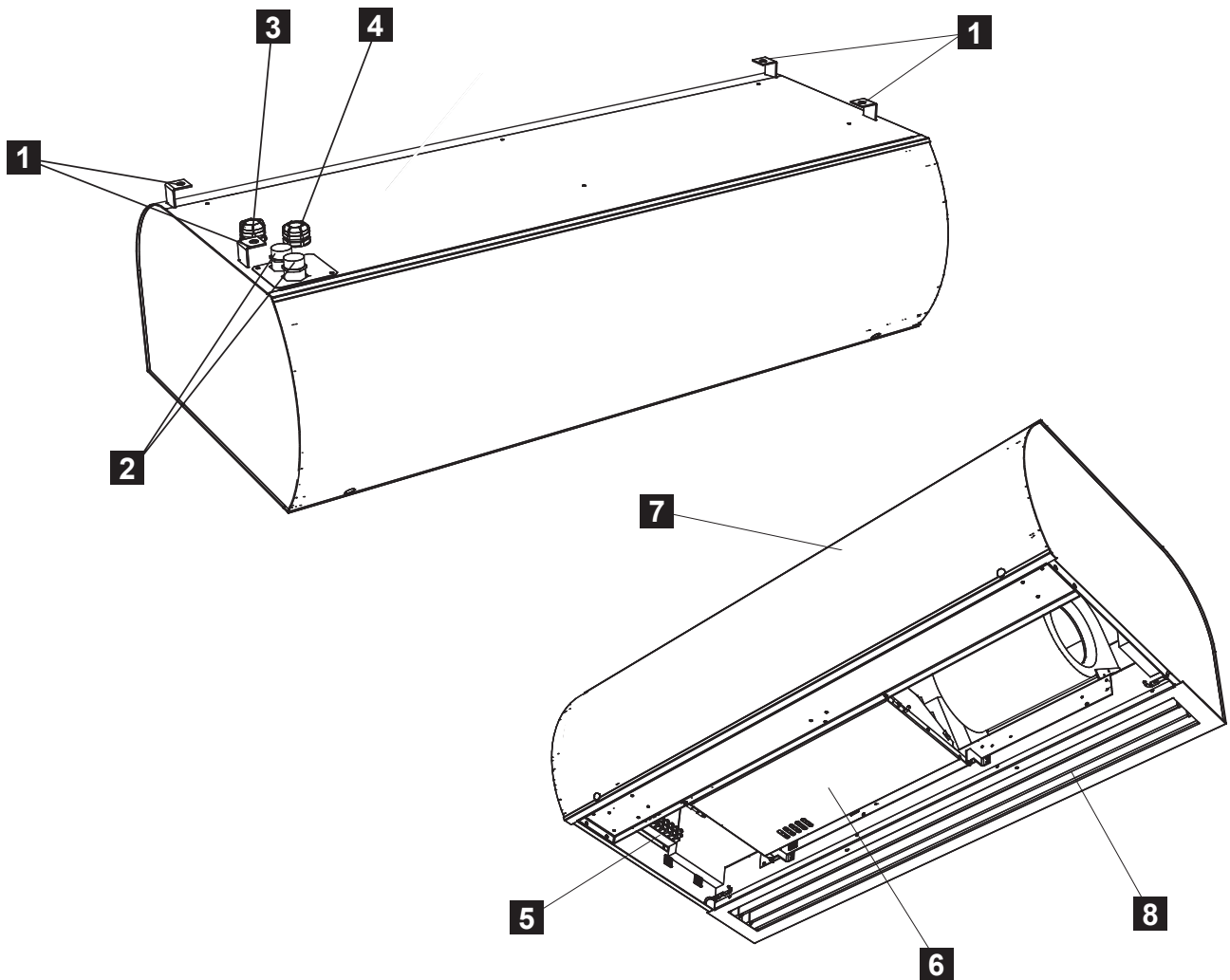

1. Mounting brackets
2. 3/4" water coil connection
3. Power supply cable connector
4. Connector for control cable (BASIC control module)
5. Connection for power supply and fuse position
6. Socket for control module
7. Cover for inlet side
8. Outlet grille

4. DIMENSIONS

Air curtain dimensions

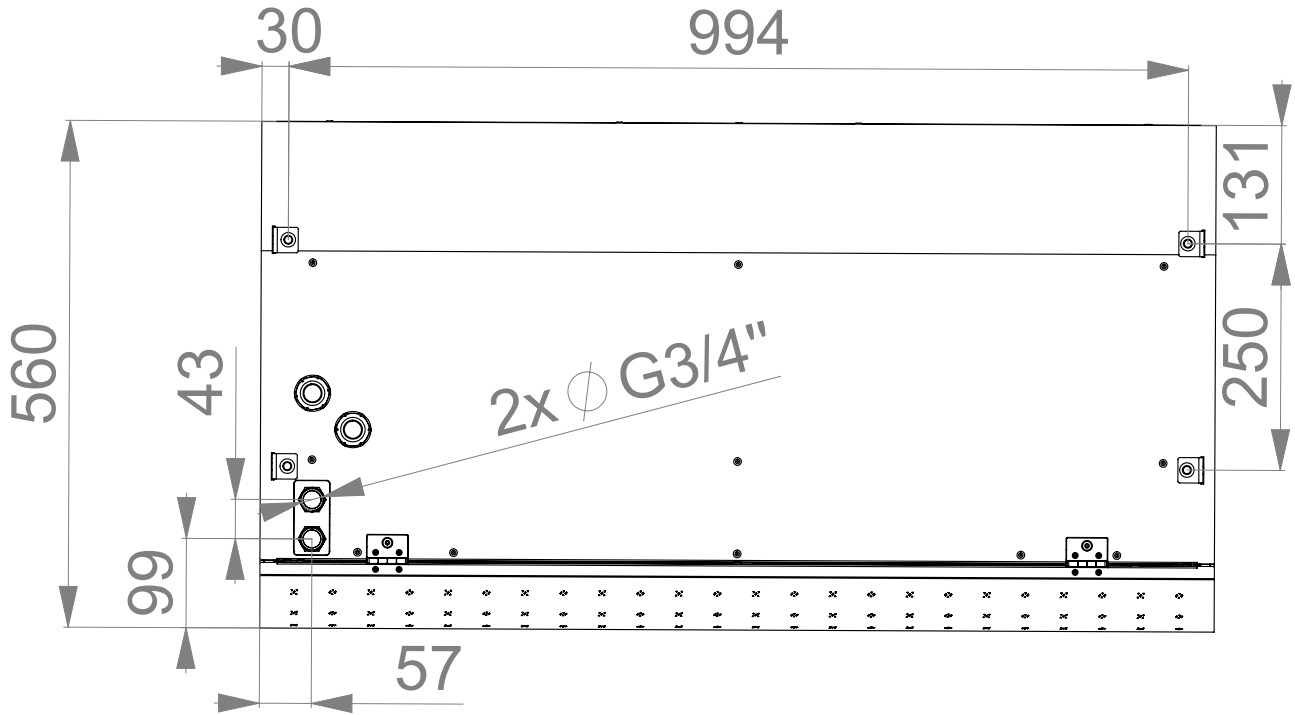

Type	Length [mm]	Width [mm]	Height [mm]
VCST5x100...	994	1054	335
VCST5x150...	1494	1554	
VCST5x-200...	1994	2054	
VCST5x-250...	2394	2454	

5. TECHNICAL PARAMETERS

VCST5 AC

Type	Heater power output [kW]		Total power input [kW] ^{*1}	Total voltage/ current [V/A]	Motor voltage/ current [V/A]	Temperature increase Δt [°C]	Frequency [Hz]	Weight [kg] ^{*4}
	1st level	2st level						
VCST5B100-S0AC	-	-	0,65	230/2,85	230/2,85	-	50	44
VCST5B150-S0AC	-	-	1,0	230/4,4	230/4,4	-	50	61
VCST5B200-S0AC	-	-	1,3	230/5,7	230/5,7	-	50	78
VCST5B250-S0AC	-	-	1,6	230/7,0	230/7,0	-	50	95
VCST5B100-E1AC	4,6	9,4	10,3	400/16,6	230/2,85	17,8*	50	48,5
VCST5B150-E1AC	7,6	15,0	16,0	400/26,1	230/4,4	18,05*	50	66
VCST5B200-E1AC	9,8	19,0	20,3	400/33,2	230/5,7	16,84*	50	84
VCST5B250-E1AC	12,5	24,5	26,1	400/42	230/7,0	18,3*	50	102
VCST5B100-V2AC	-	-	0,65	230/2,85	230/2,85	39,5 ^{*2}	50	50
VCST5B150-V2AC	-	-	1,0	230/4,4	230/4,4	40,6 ^{*2}	50	67
VCST5B200-V2AC	-	-	1,3	230/5,7	230/5,7	41,5 ^{*2}	50	85
VCST5B250-V2AC	-	-	1,6	230/7,0	230/7,0	42,0 ^{*2}	50	99
VCST5C100-S0AC	-	-	0,95	230/4,0	230/4,0	-	50	48
VCST5C150-S0AC	-	-	1,35	230/5,6	230/5,6	-	50	64
VCST5C200-S0AC	-	-	1,7	230/7,0	230/7,0	-	50	80
VCST5C250-S0AC	-	-	2,0	230/8,7	230/8,7	-	50	98
VCST5C100-E1AC	4,6	9,9	10,6	400/17,6	230/4,0	12,5 *	50	53
VCST5C150-E1AC	7,6	15,0	17,0	400/27,5	230/7,0	13,66 *	50	68
VCST5C200-E1AC	9,8	19,0	20,8	400/34,2	230/8,7	13,88 *	50	86
VCST5C250-E1AC	12,5	24,5	26,5	400/44	230/6,9	14,94 *	50	110
VCST5C100-V2AC	-	-	0,95	230/4,0	230/4,0	35,1 ^{*2}	50	55
VCST5C150-V2AC	-	-	1,35	230/5,6	230/5,6	37,3 ^{*2}	50	70
VCST5C200-V2AC	-	-	1,7	230/7,0	230/7,0	39,3 ^{*2}	50	88
VCST5C250-V2AC	-	-	2,0	230/8,7	230/8,7	40,8 ^{*2}	50	108
VCST5C100-V3AC	-	-	0,95	230/4,00	230/4,00	12,6 ^{*3}	50	85
VCST5C150-V3AC	-	-	1,35	230/5,60	230/5,60	13,9 ^{*3}	50	72
VCST5C200-V3AC	-	-	1,70	230/7,00	230/7,00	14,0 ^{*3}	50	90
VCST5C250-V3AC	-	-	2,00	230/8,70	230/8,70	13,9 ^{*3}	50	110

*1 At the maximum air flow and maximum heater power.

*2 Intake air temperature +18°C, water temperature gradient of 90/70 °C and highest fan speed.

*3 Intake air temperature +18°C, water temperature gradient of 40/30 °C and highest fan speed.

*4 Weight with control BASIC

VCST5 EC

Type	Heater power output [kW]		Total power input [kW] ^{*1}	Total voltage/ current [V/A]	Motor voltage/ current [V/A]	Temperature increase Δt [°C]	Frequency [Hz]	Weight [kg]
	1st level	2st level						
VCST5B100-S0EC	-	-	0,34	230/2,4	230/2,4	-	50/60	40
VCST5B150-S0EC	-	-	0,50	230/3,4	230/3,4	-	50/60	55
VCST5B200-S0EC	-	-	0,68	230/4,4	230/4,4	-	50/60	70
VCST5B250-S0EC	-	-	0,85	230/5,4	230/5,4	-	50/60	85
VCST5B100-E1EC	4,6	9,4	9,74	400/16,0	230/2,4	14,7	50/60	45
VCST5B150-E1EC	7,6	15,0	15,50	400/25,1	230/3,4	16,0	50/60	60
VCST5B200-E1EC	9,8	19,0	19,68	400/31,9	230/4,4	14,9	50/60	76
VCST5B250-E1EC	12,5	24,5	25,35	400/40,8	230/5,4	15,5	50/60	92
VCST5B100-V2EC	-	-	0,34	230/2,4	230/2,4	38,6 ^{*2}	50/60	46
VCST5B150-V2EC	-	-	0,50	230/3,4	230/3,4	38,5 ^{*2}	50/60	61
VCST5B200-V2EC	-	-	0,68	230/4,4	230/4,4	39,6 ^{*2}	50/60	77
VCST5B250-V2EC	-	-	0,85	230/5,4	230/5,4	40,1 ^{*2}	50/60	89
VCST5C100-S0EC	-	-	0,50	230/3,3	230/3,3	-	50/60	44
VCST5C150-S0EC	-	-	0,68	230/4,5	230/4,5	-	50/60	59
VCST5C200-S0EC	-	-	0,84	230/5,3	230/5,3	-	50/60	73
VCST5C250-S0EC	-	-	1,20	230/7,2	230/7,2	-	50/60	91
VCST5C100-E1EC	4,6	9,9	9,90	400/16,9	230/3,3	11,6	50/60	50
VCST5C150-E1EC	7,6	15,0	15,68	400/21,2	230/4,5	12,3	50/60	64
VCST5C200-E1EC	9,8	19,0	19,84	400/32,8	230/5,3	10,0	50/60	80
VCST5C250-E1EC	12,5	24,5	25,70	400/42,6	230/7,2	11,4	50/60	104
VCST5C100-V2EC	-	-	0,50	230/3,3	230/3,3	34,5 ^{*2}	50/60	51
VCST5C150-V2EC	-	-	0,68	230/4,5	230/4,5	34,7 ^{*2}	50/60	65
VCST5C200-V2EC	-	-	0,84	230/5,3	230/5,3	36,9 ^{*2}	50/60	81
VCST5C250-V2EC	-	-	1,20	230/7,2	230/7,2	36,1 ^{*2}	50/60	101
VCST5C100-V3EC	-	-	0,50	230/3,3	230/3,3	12,0 ^{*2}	50/60	53
VCST5C150-V3EC	-	-	0,68	230/4,5	230/4,5	12,9 ^{*3}	50/60	69
VCST5C200-V3EC	-	-	0,84	230/5,3	230/5,3	13,2 ^{*3}	50/60	85
VCST5C250-V3EC	-	-	1,20	230/7,2	230/8,7	13,1 ^{*3}	50/60	104

*1 At the maximum air flow and maximum heater power.

*2 Intake air temperature +18°C, water temperature gradient of 90/70 °C and highest fan speed.

*3 Intake air temperature +18°C, water temperature gradient of 40/30 °C and highest fan speed.

*4 Weight with control BASIC

6. INSTALLATION

6.1 CHOOSE THE INSTALLATION SITE AND INSTALL THE AIR CURTAIN

6.1-1 Built up dimensions

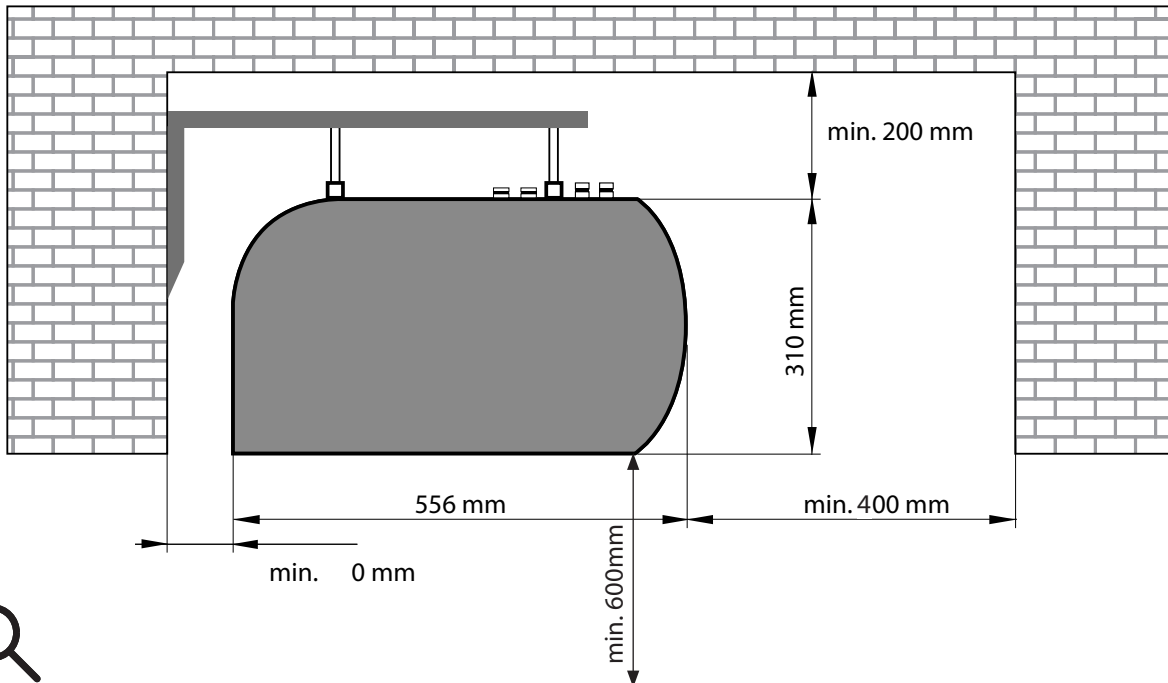

- The air curtain must be installed only in a horizontal position!
- The curtain can be installed over the door opening. All separation distances for flammable materials and safe use of air curtain has to be kept.
- The installed position of the air curtain can be chosen to accommodate the service hood.
- It must be operated in dry, covered indoor spaces with an ambient temperature between +5° C and +40° C and relative humidity up to 80%
- The air curtain is not intended for moving air that contains combustible or explosive mixtures, chemical fumes, coarse dust, soot, grease, poisons, infectious germs, etc.

6.1.-2 Clearance distance

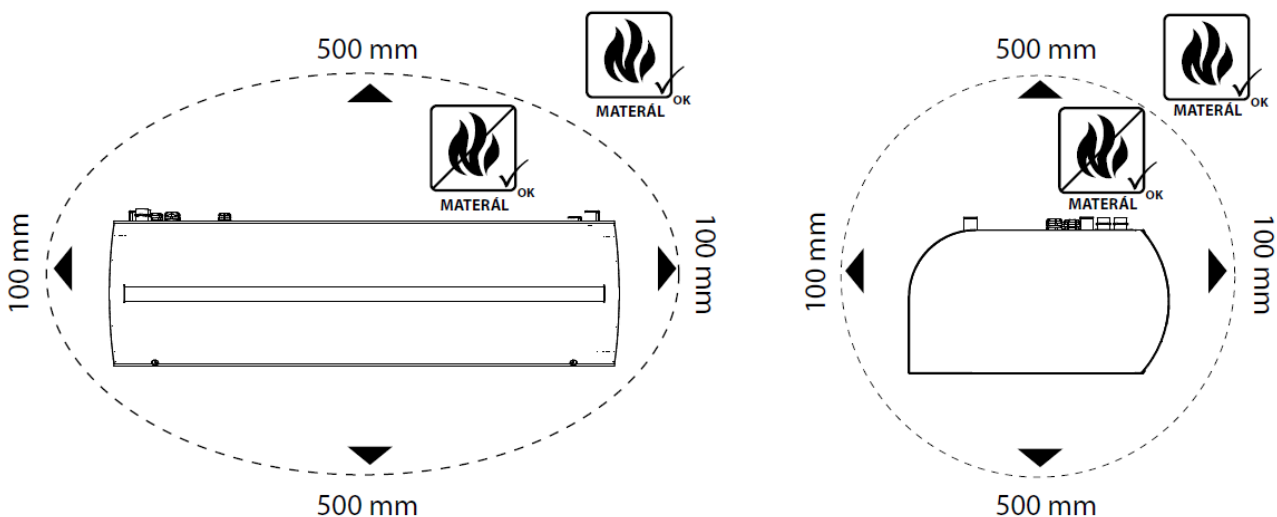

6. INSTALLATION

6.1-3 Measure the installation site

- Only nonflammable materials (those that do not burn, smoulder or carbonise) or fire-resistant materials (those that do not burn, but mainly smoulder, e.g., plaster board) can be kept within 100 mm in any direction of the air curtain. However, these materials should not block the intake or outlet openings
- For air curtains with an electric heater, safe distances from building structural surfaces and flammable objects are as follows
- The safe distance for flammable materials in the direction of the main air flow (i.e., behind the outlet) is 500 mm
- The safe distance for flammable materials above the air curtain is 500 mm
- The safe distance for flammable materials in other directions is 100 mm.

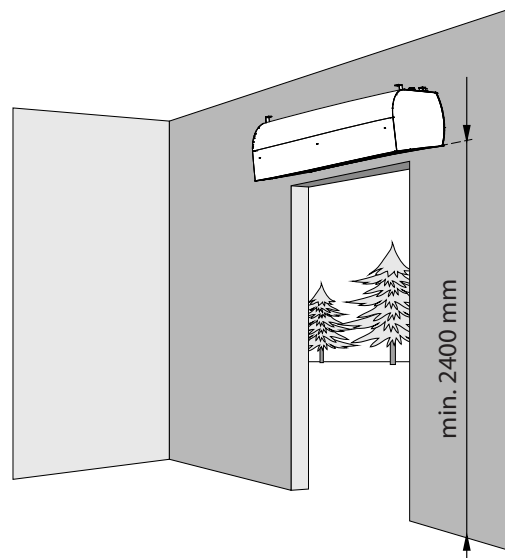
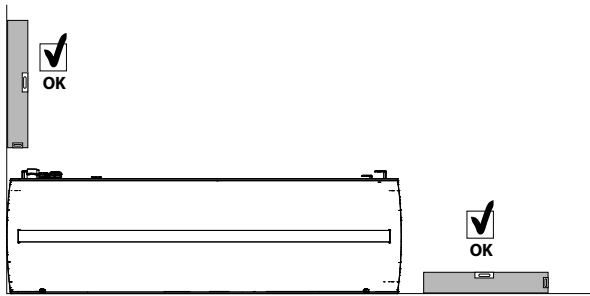

6.1-3 Measure the installation site

Choose the location for the installation and measure the installation site. Measure out the dimensions of ceiling installation or for wall mounted brackets.

- It is necessary to ensure proper in the supply at the site according to the exact type of use of the air curtain and based on its electric parameters.
- When using water heated air curtain, please ensure connection of the flow and return pipes.

6. INSTALLATION



For wall installation use Wall mounted bracket set: VCS4-KONZ-STE.
Wall mounted bracket has to be ordered separately as an optional accessory.

Size of bracket VCS4-KONZ-STE

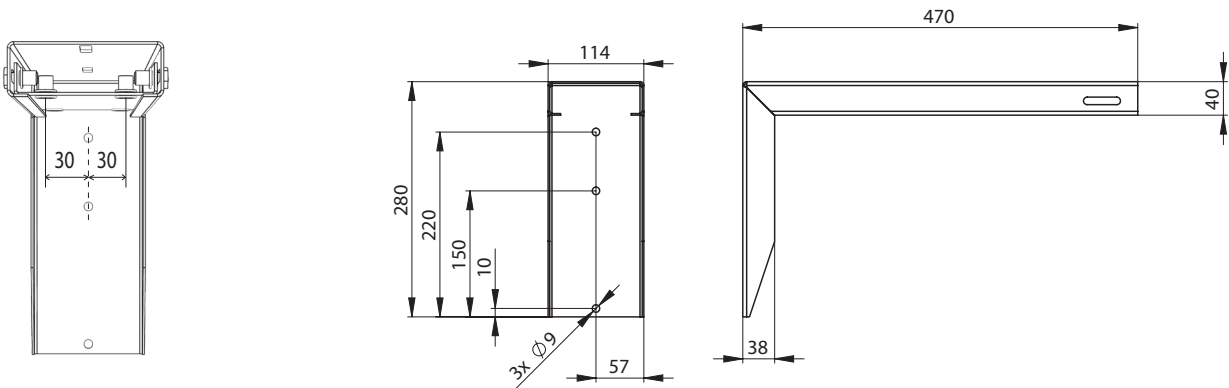

Installation distance

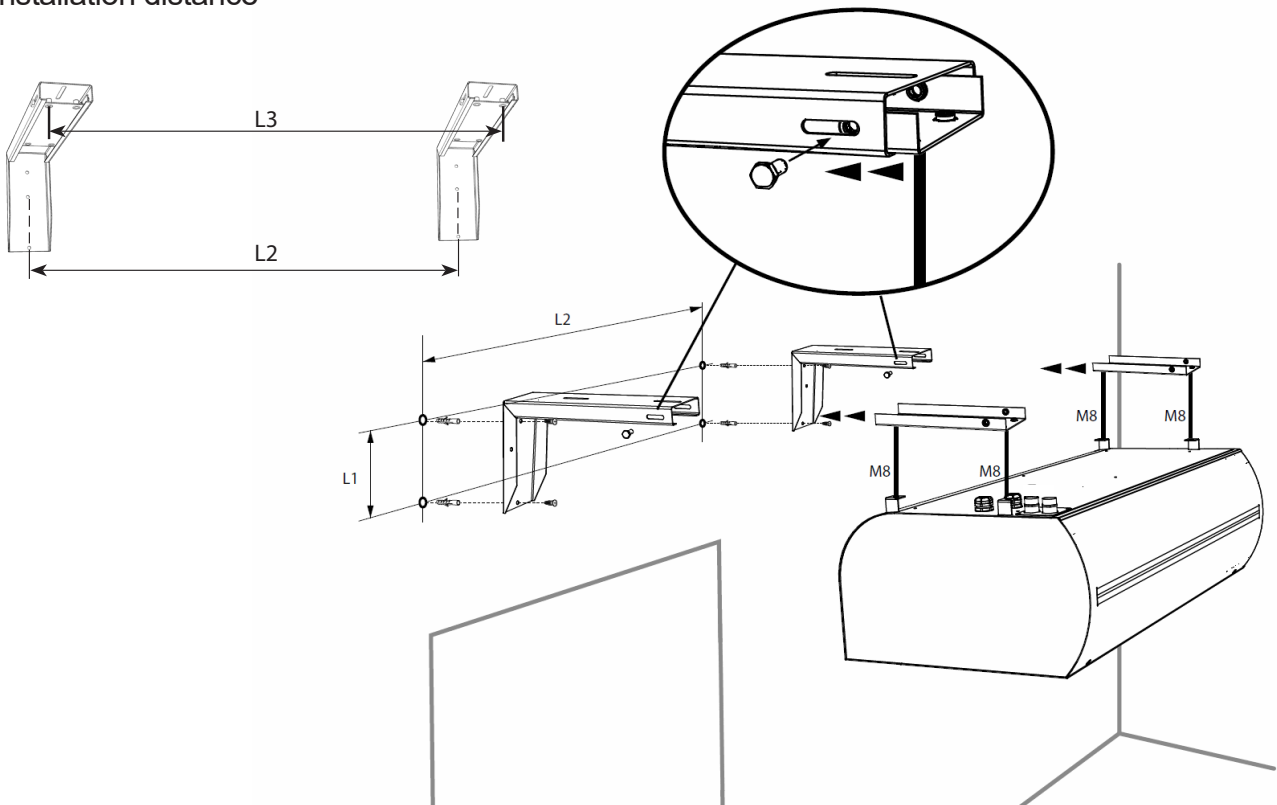

Model	L2 [mm]	L1 [mm]
VCST5x-10x-x..	994	210
VCST5x-15x-x..	1494	210
VCST5x-20x-x..	1994	210
VCST5x-25x-x..	2394	210

6. INSTALLATION



For ceiling installation use Ceiling holder SET: VCS4-KONZ-STR. Ceiling holder SET has to be ordered separately as an optional accessory.

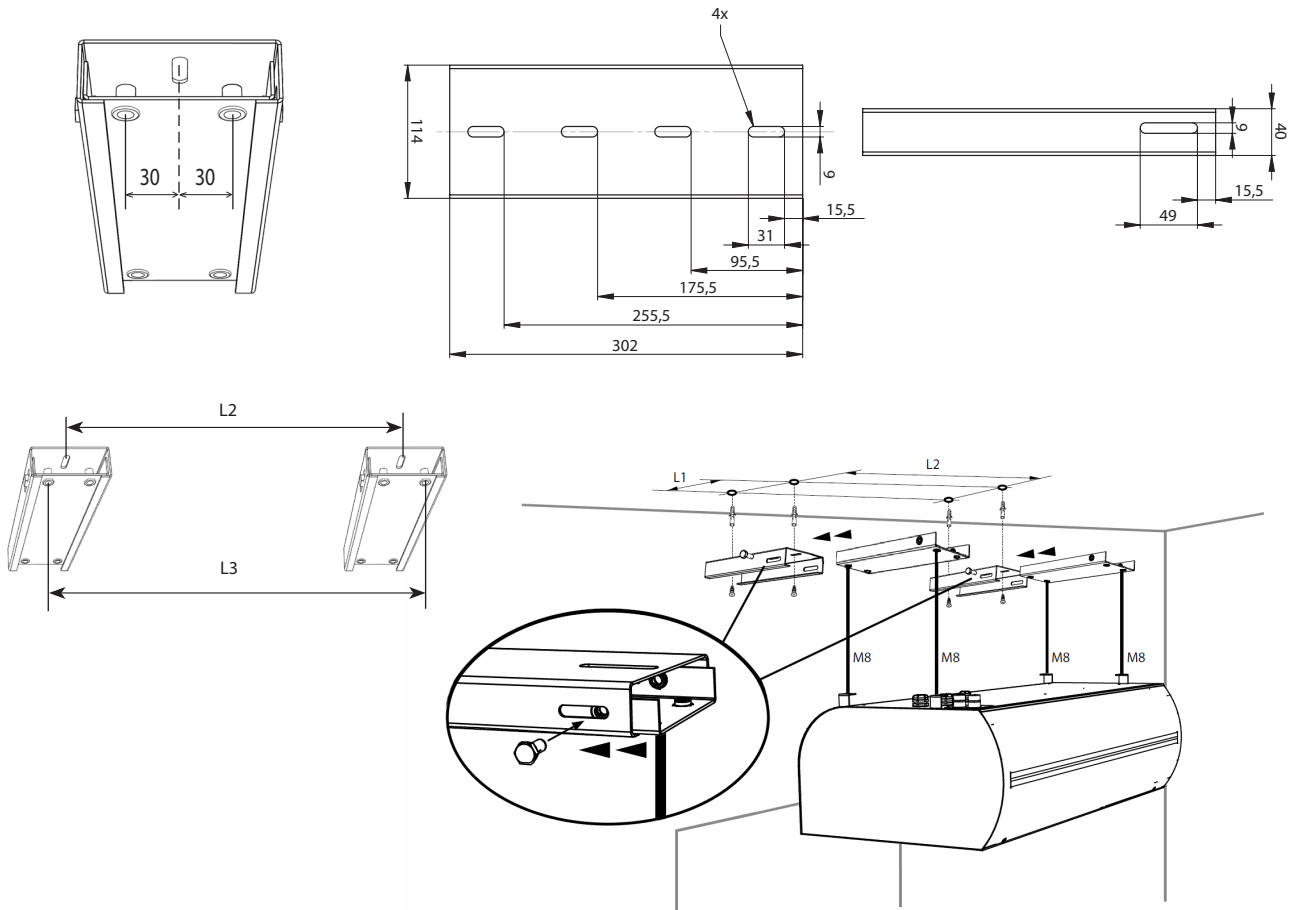

Model	L2 [mm]	L1 [mm]
VCST5x-10x-x..	994	240
VCST5x-15x-x..	1494	240
VCST5x-20x-x..	1994	240
VCST5x-25x-x..	2394	240

6.1-4 Suspend the air curtain on the threaded bars and ensure that the suspension will not come loose



- In consideration of the air curtain weight into account, it is necessary to use either a suitable lifting device (forklift, etc.) or use two additional individuals to support it, as long as it is not securely fastened.
- Suspension has to carry the weight of the air curtain!

6. INSTALLATION

6.2 CONNECT THE WATER INTAKE AND OUTLET HOSES

VCST5x-xxx-V(W)-...



- A flexible hoses with a G3/4" connection



- Connection and pressure testing of the heater must be carried out by a person with professional plumbing knowledge, who must observe current standards and regulations of the given country.
- The maximum water temperature is +100° C. The maximum pressure is 1.6 MPa. We recommend installing a stop valve on the intake and outlet of the heater to allow the water supply to be shut off .

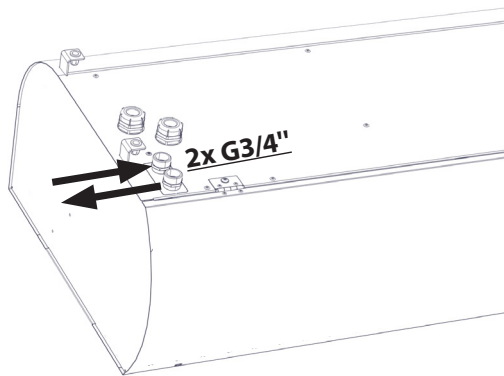

6.2-1 Regulating the water coil with a ZV3-230 or RT zone valve



Zone valve **ZV3-230** is an required accessorie for control module BASIC.
For air curtain with water heat exchanger and BASIC control module with a jumper between GND and Tx.

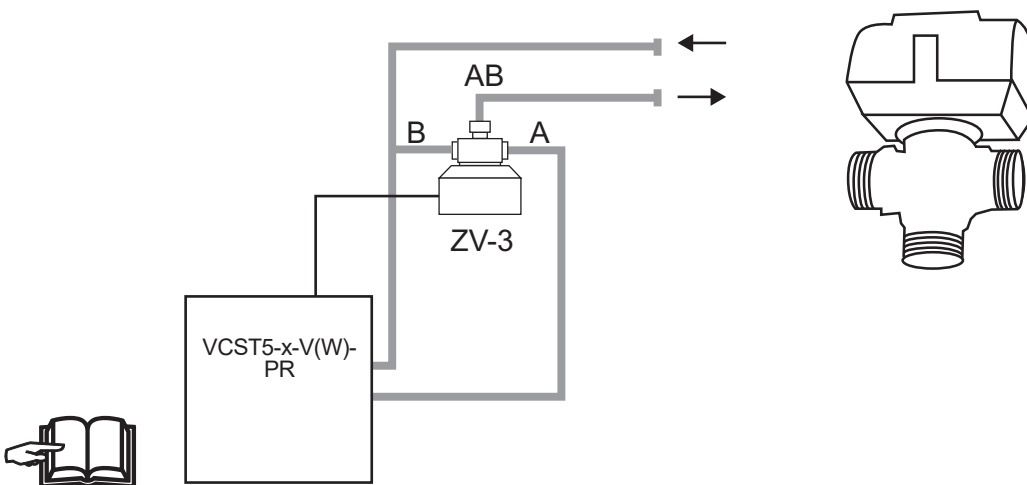

- Detailed description of water coil regulation by zone valve (ZV3-230), including it's connection, refer the instruction manual for zone valve ZV3-230.

6. INSTALLATION

6.3 ELECTRO INSTALLATION



- The air curtain's electrical connection must be based on a professional design by a qualified electrical systems engineer.
- Installation must be carried out by a professionally trained electrical worker. All applicable national regulations and directives must be observed.
- The electrical schematics on the product take priority over those presented in this manual!
- Prior to installation, check to see if the terminal markings correspond to the markings on the electrical connections diagram. When in doubt, contact your supplier and do not connect the air curtain under any circumstances.
- Never reach inside the air curtain unless the main electrical supply has been turned off !
- If the product is connected to any control system other than the original one, the regulation and measurement components must be connected by the company that supplied the system.
- The electrical contractor defines the minimum size of the feed cable according to the standards applicable at the place of installation, the location for installing the cable, the surrounding conditions, and the curtain's technical parameters.



Special attention should be paid to the capacity of the distribution network of the air curtain with electric heater in terms of the supply of the appropriate phase current values for limiting the voltage fluctuations and flickering in the network.

The minimum cable dimensions must be used in accordance with the technical values indicated on the product label and in accordance with the applicable laws and regulations of the country.

Fuse specification:

VCST5-x-xxx...		x	
		B	C
xxx	100	3,15A	5A
	150	4A	6,3A
	200	6,3A	8A
	250	8A	12A

6. INSTALLATION

VCST5-xxx-S / V

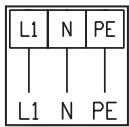

VCST5-xxx-E

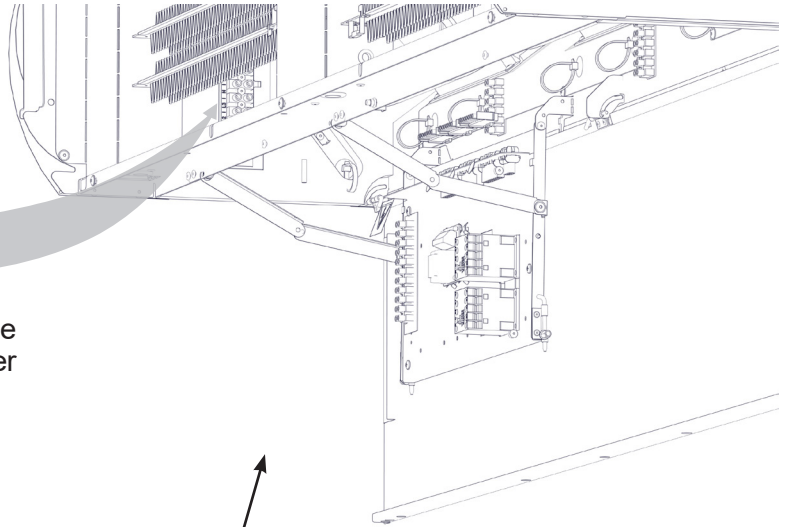
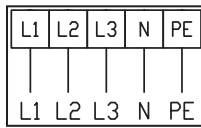

The electrical parameters are shown on the manufacturer's label, which is located under the air curtain's service cover.

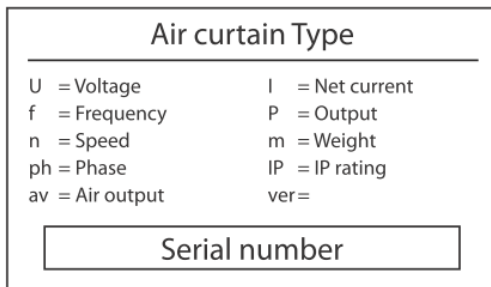

Motors and board fuse
5x20
250V AC
T_{xx}A

- The air curtain must be protected by an appropriate circuit breaker, in accordance with its electrical parameters. For safety reasons, over-designed protection is not recommended.
- The air curtain must be connected using the TN-S system, which means that the neutral conductor must always be connected.
- A main cut-off switch must be placed in the electrical supply network, disconnecting all poles of the network.
- The electrical enclosure of the air curtain is IP 20.



STANDESSE air curtains are equipped with a fuse (with T characteristic – slow-blow). This safety fuse protects the electronic panel and fans. It is located under the service cover next to the main power supply connectors.

6.4 CONNECTION THE CONTROL PANEL

Unscrew the screws and open the regulation cover

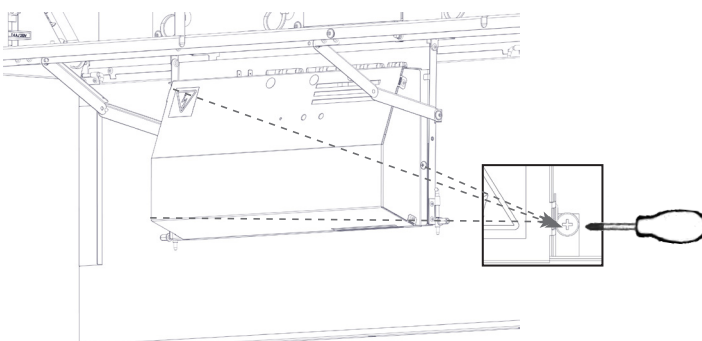

6. INSTALLATION

DIMENSION

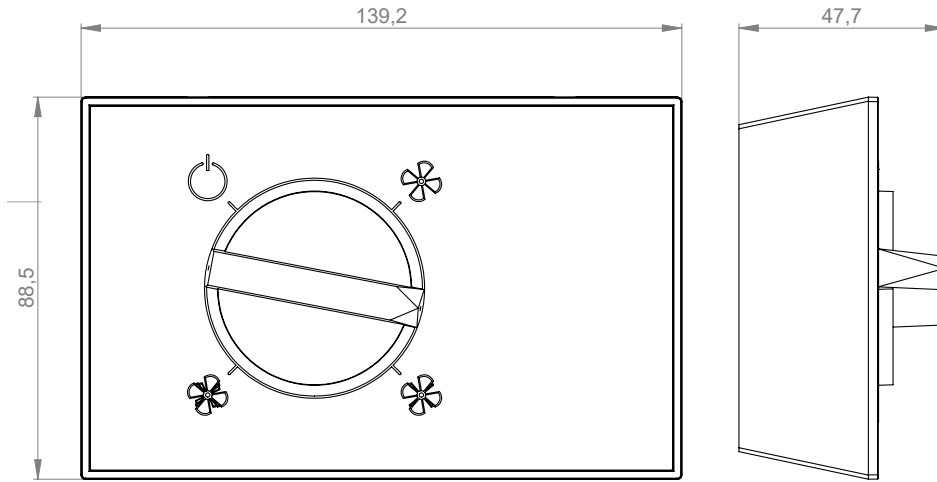

INSTALLATION OF CONTROL PANEL

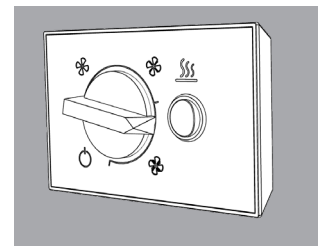
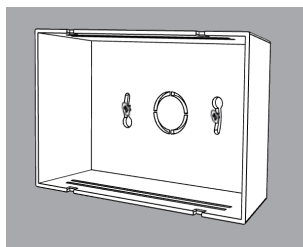
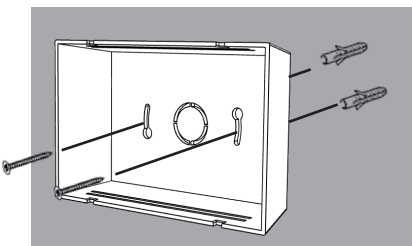
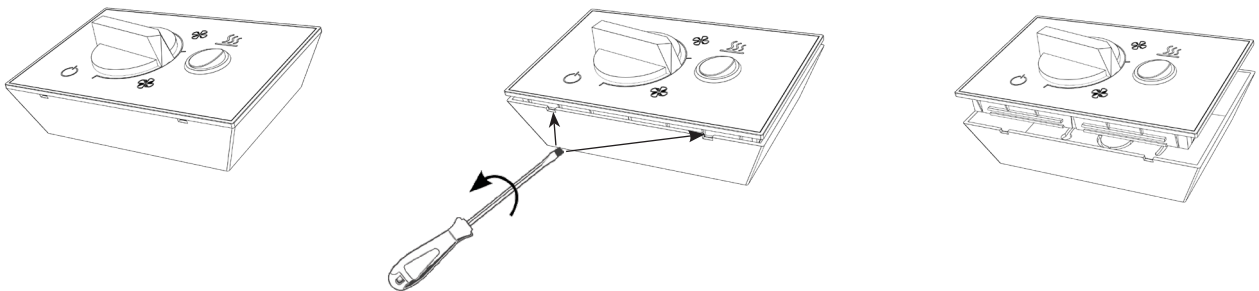

*The controller can only be installed on a wall or on a fixed non-portable object.
The cable must be secured against being pulled out of the controller..*

6. INSTALLATION

CONTROL

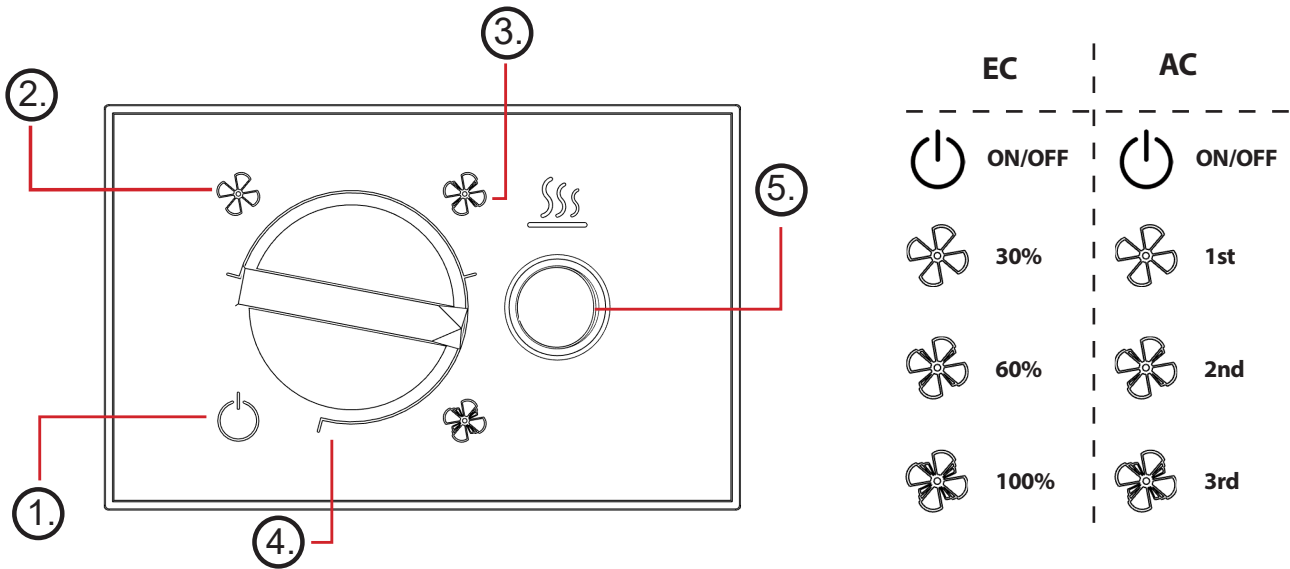

1	OFF - fan OFF, heating not active
2	Low fan speed, heating enabled (heating level 1 enabled)
3	Medium fan speed, heating enabled (heating level 1 and 2 enabled)
4	High fan speed, heating is enabled (heating level 1 and 2 enabled)
5	Heating switch (water heater = heating level 1, electric heater = heating level 1 and 2)

6. INSTALLATION

BASIC EC DESCRIPTION

Controls description:

- Control EC motors with 0-10V continuous output
- Control heating output in the range of OFF / Stage 1 / Stage 2 using potential-free relay outputs with a maximum relay load of 230V / 5A. NOTE: Not available for the non-heating version
- Connect a door contact or external switch (by switching off the whole product when the contact is opened)
- Connect room thermostat (switch off heating when contact is opened) - NOTE: Not available for version without heating

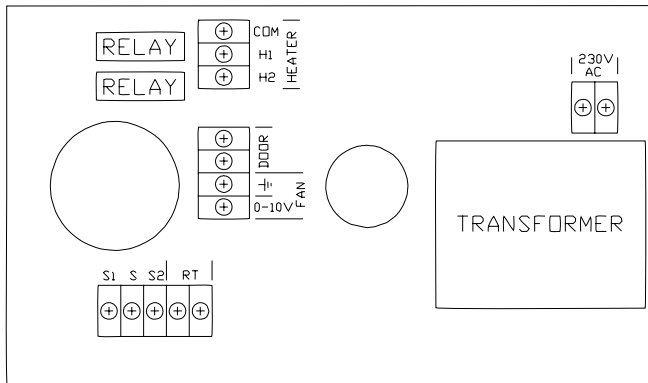

TERMINAL	FUNCTIONALITY	DESCRIPTION
S1	ENTRY TO THE INTERNAL HEAT CONTROLLER SWITCH	SWITCH FOR 1ST HEATING STAGE (FACTORY WIRED)
S		COM INTERNAL HEATING SWITCH (FACTORY WIRED)
S2		SWITCH FOR 2ND HEATING STAGE (FACTORY WIRED)
RT	ROOM THERMOSTAT	DI SWITCHES ONLY THE THERMAL OUTPUTS ON/OFF (FACTORY WIRED = ELECTRICALLY CONNECTED)
COM	COM HEATING	INPUT FOR HEATING CONTROL SIGNAL (MAX. LOAD 230V/5A)
H1	1. HEATING STAGE	OUTPUT OF THE 1ST HEATING STAGE
H2	2. HEATING STAGE	OUTPUT OF THE 2ND HEATING STAGE
DOOR	DOOR CONTACT (EXT CTRL, ROOM THERMOSTAT)	DI SWITCHING ON/OFF COMPLETE CONTROLLER (FAN AND HEATER)
0-10V DC	0-10V MOTOR CONTROL	OUTPUT FOR MOTOR CONTROL (MAX. 10 MOTORS)
GND	GND MOTOR CONTROL	
~230V	L - 230VAC	MAIN POWER SUPPLY 230V
	N - 230VAC	

NOTE: Terminals S1, S, S2, RT, COM, H1, H2 are not used for the non-heated screen. The non-heated version only supports fan control and connection of an external contact to the DOOR terminals (door switch, external control switch, ...).

6. INSTALLATION

CONNECTION OF THE CONTROLLER AND ACCESSORIES

BASIC AC

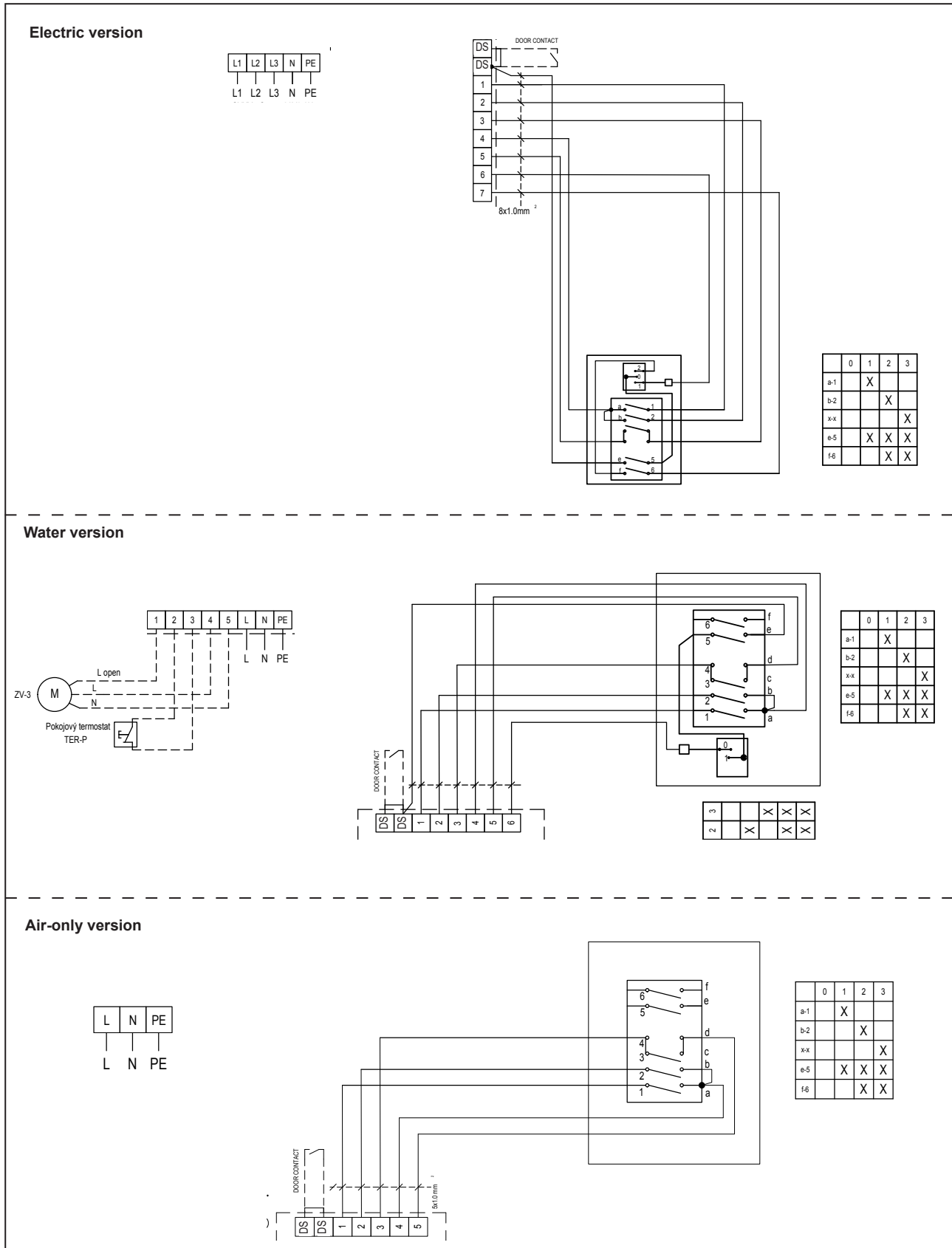

8. ACCESSORIES

CONNECTION OF EXTERNAL ACCESSORIES



DON'T OVERLOOK

When connecting external accessories, the air curtain must be disconnected from the power supply. The air vent must be disconnected from the mains.

All external control components must be wired according to the wiring diagram.

Connectors must be plugged into the electrical board with adequate force and always perpendicular to the base.

Door switch DS (for **Basic AC / EC** controls)



TECHNICAL INFORMATION

- Suitable for all BASIC controls
- Isolated opening contact with maximum voltage 230V, 6A
- IP67, can be connected as a switching or opening contact



ATTENTION!

Not supplied with the product.

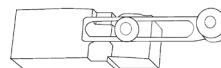

Door switch DK-B3 (for **Basic EC** control only)



TECHNICAL INFORMATION

- Isolated door contact with maximum voltage 12V.
- Cable: Maximum length: 50 m



ATTENTION!

Not supplied with the product.



Thermostatic valve– TV1/1



TECHNICAL INFORMATION

- Thermostatic valve for water exchanger control
- Suitable for all types of screens with water heat exchanger



ATTENTION!

Not supplied with the product.

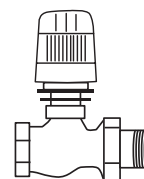

Zone valve ZVx-230 / RT-3-xx



TECHNICAL INFORMATION

- Zone valve for water heat exchanger control
- Cable: Three-conductor cable with a cross-section of 1.5 mm², 230 V/ 50 Hz.



ATTENTION!

Not supplied with the product.

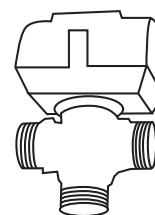

6. INSTALLATION

6.9 EXIT SIGN



- Exit sign marking of emergency exit



Not included in delivery.

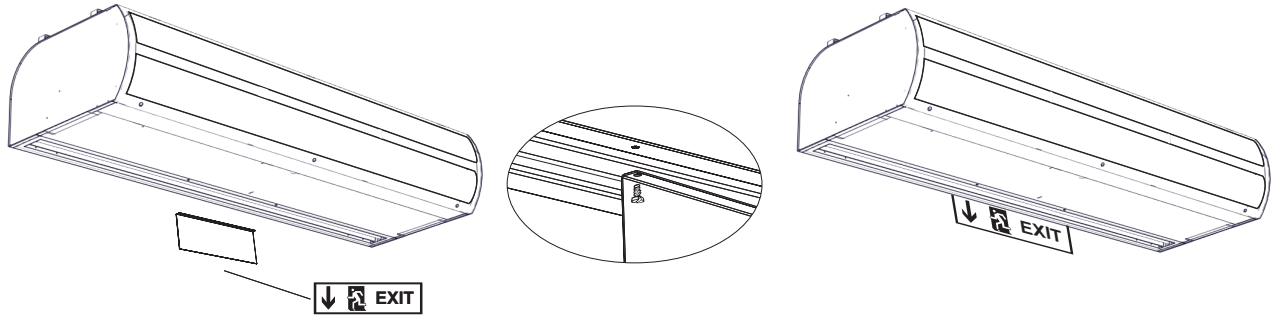

6.10 COVERING THE AIR CURTAIN + FILTERS

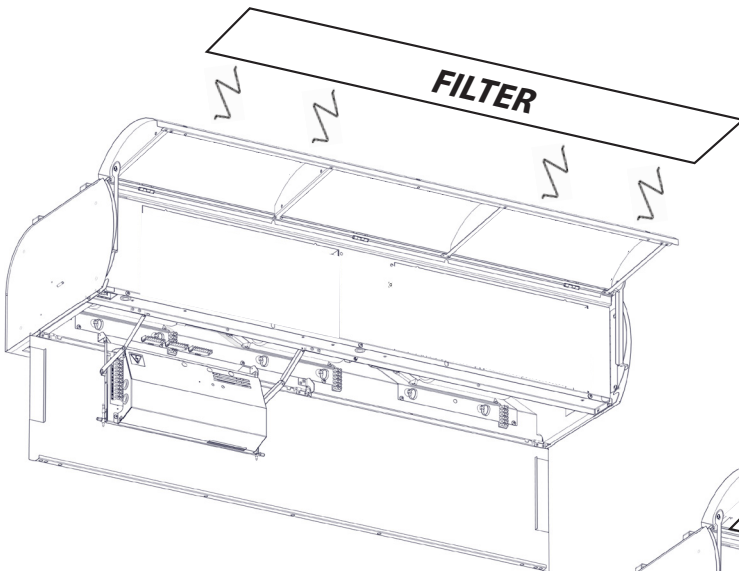

**NUMBER OF SPRINGS DEPENDING
ON THE LENGTH OF THE UNIT**

1m - 2 pcs
1,5m - 3 pcs
2m - 4 pcs
2,5m - 4 pcs

**Do not use with the electric
version!!**

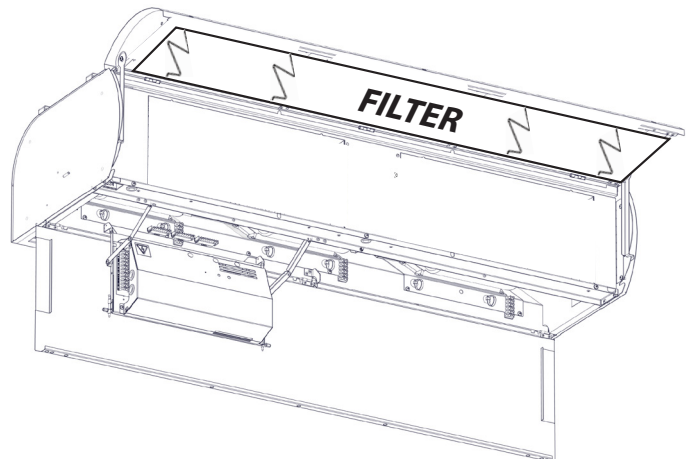

10. SERVIS

10.1 RESETTING THE EMERGENCY THERMOSTAT

The main electrical supply must be switched off before any tampering with the inside of the air curtain. The air curtain must be allowed to cool down!

- Clean the surface and the inside of the air curtain, including the intake section.
- Visual inspection of the orifice, heating exchanger and wiring.
- Check of emergency thermostats and subsequent reset.

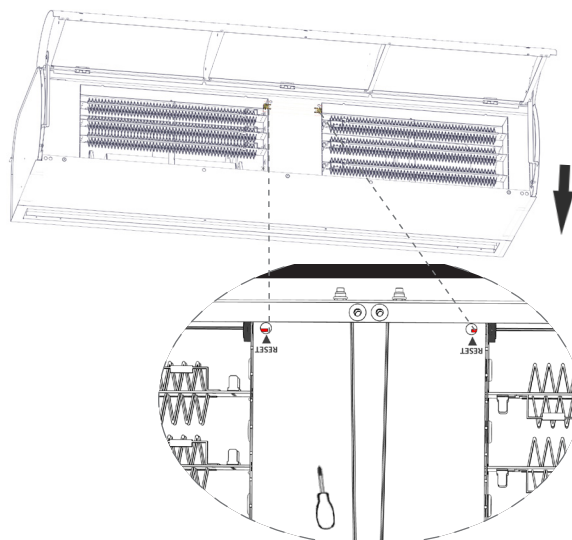

10.2 WHEN YOU AREN'T ABLE TO REMOVE DEFECT BY YOURSELF

If you are unable to resolve the problem, contact the supplier.
For the fast removal of defects please provide the following information:

- product reference number
- serial number
- running time
- used accessories
- installation location
- installation condition (including electrical)
- detailed description of the problem and the steps that you have taken for its removal

Warranty and post-warranty service is performed by the manufacturer, supplier or authorized service organization. When ordering service intervention it is necessary to describe the defect, product type designation indicated on its label, and the location of installation.

PUTTING THE PRODUCT OUT OF OPERATION - DISPOSAL

Before disposing of the product, make the product unusable. Even old products contain raw materials that can be reused. Take them to a collection point of secondary raw materials.

The product is good to dispose at the place, which is specialized for it, and thus it will be possible to recycle materials. Store unusable parts of the product at a controlled dump.



When disposing of materials, it is necessary to observe the relevant national regulations on waste disposal.

12. CONCLUSION

After installing the air curtain, read carefully the **Manual for the appropriate regulator**. In case of any doubt or query, do not hesitate to contact our sales or technical support departments.

CONTACT

Address:

2VV s.r.o.
Nádražní 794
533 51 Pardubice - Rosice
Czech Republic

Internet:

<http://www.2vv.cz/>

