



PARTNER  
IN VENTILATION  
2VV.CZ

EN

# STANDESSE AC/EC (VCST5-B/C)

## PRIME

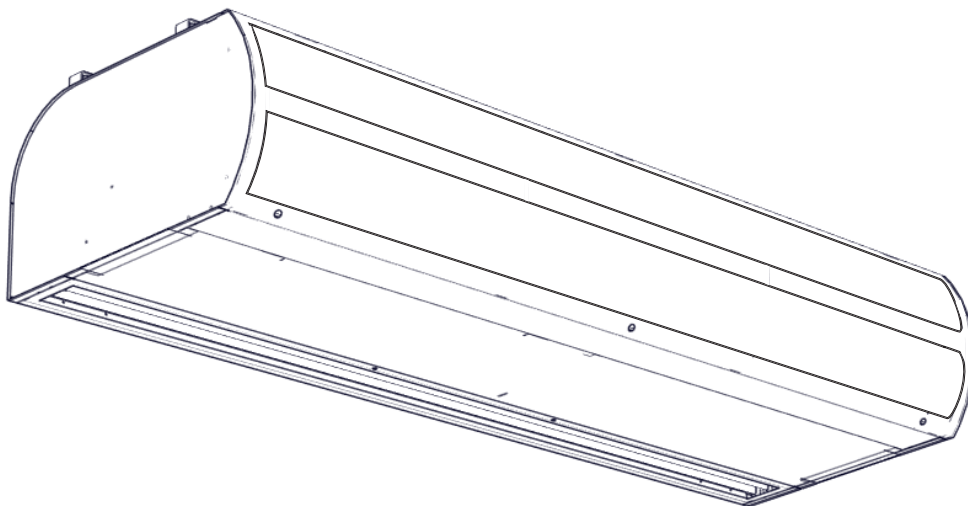

### INSTALLATION AND OPERATION

# 1. BEFORE YOU BEGIN

Meaning of symbols in the manual:

SYMBOL	MEANING
<b>ATTENTION!</b>	Warning or notice
<b>READ CAREFULLY!</b>	Important instructions
<b>YOU WILL NEED</b>	Practical tips and information
<b>TECHNICAL INFORMATION</b>	Detailed technical information
	Reference to another point/section of the manual



Before installing, read carefully the section **Safe use of the air curtains**, where you will find all the instructions for the safe and proper use of the product.

This manual includes important instructions for the appropriate installation of the air curtains. Before installing, read carefully all the following instructions and observe them. The manufacturer reserves the right to change, including the technical documentation, without prior notice. Keep the manual for future use. The instructions herein are part of the product

**Declaration of conformity**

Details can be found at [www.2vv.cz/en/](http://www.2vv.cz/en/)

## 2. UNPACKING

### 2.1 CHECK THE SHIPMENT

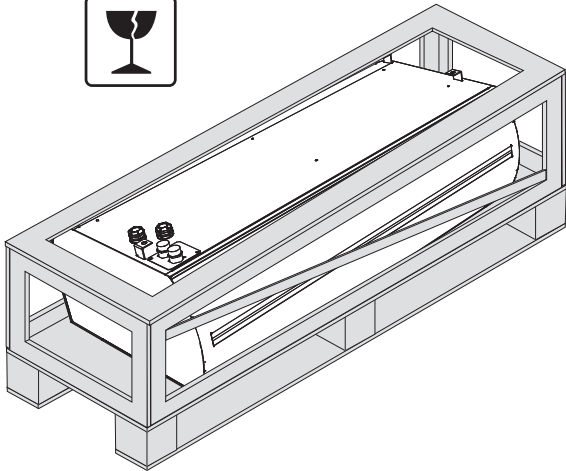

- After delivery, immediately check to see if the packaged product is damaged. If the packaging is damaged contact the delivery service. If the complaint is not filed in time, your claim may not be valid later.
- Check to see if it is the same product you ordered. If there are any discrepancies, do not unpack the curtain, and immediately report the defect to the supplier.
- After unpacking, check to see if the curtain and other parts are in order. If you have any doubts, contact the supplier.
- Never install a damaged air curtain!
- If you do not unpack the curtain immediately after delivery, it must be stored in a dry indoor environment with an ambient temperature between **+5 °C and +40 °C**

	<p>All the packaging material is environmentally friendly and can be reused or recycled. Contribute actively to the protection of the environment and ensure the proper disposal or recycling of the packaging materials.</p>	
--	---	--

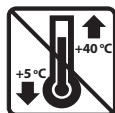

### 2.2 CONTENTS

#### MASTER

1x

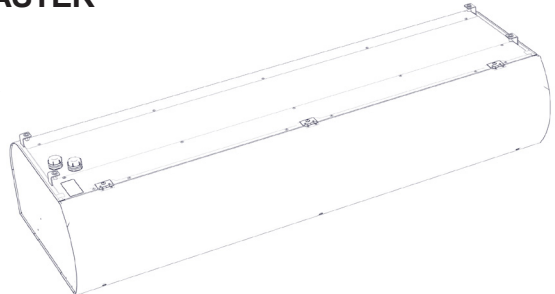

1x



1x

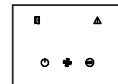

1x

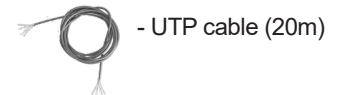

#### SLAVE

1x

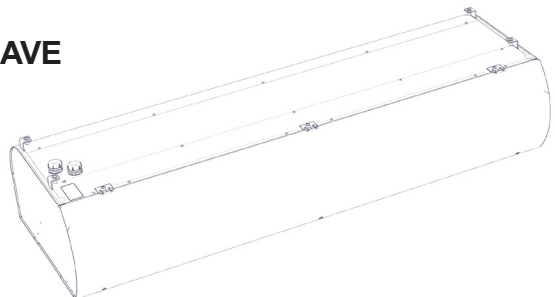

1x



1x

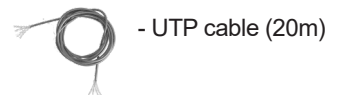

### 3. MAIN PARTS

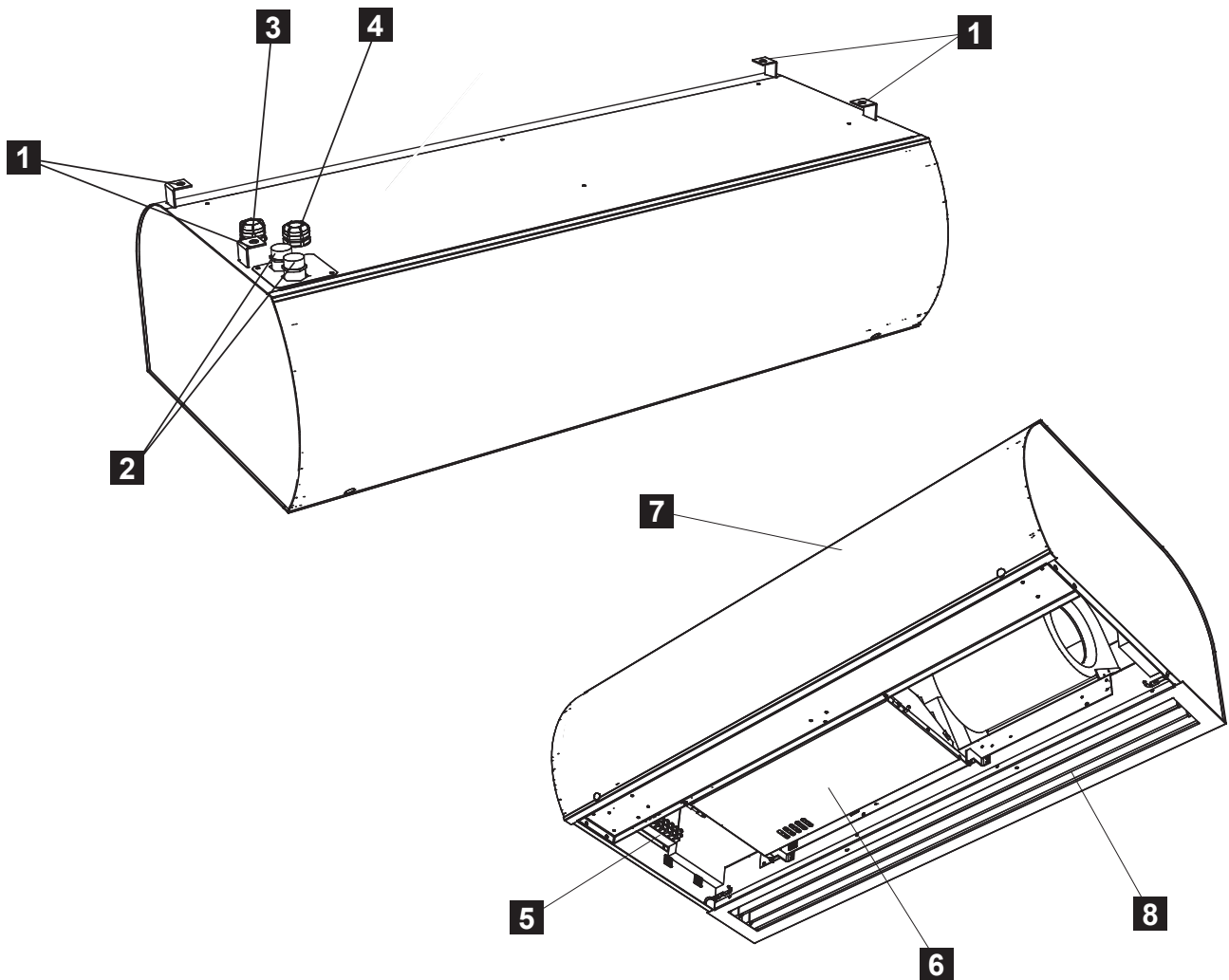

1. Mounting brackets
2. 3/4" water coil connection
3. Power supply cable connector
4. Connector for control cable (BASIC control module) or connector for water coil controller cable (PRIME control modules)
5. Connection for power supply and fuse position
6. Socket for control module
7. Cover for inlet side
8. Outlet grille

## 4. DIMENSIONS

Air curtain dimensions

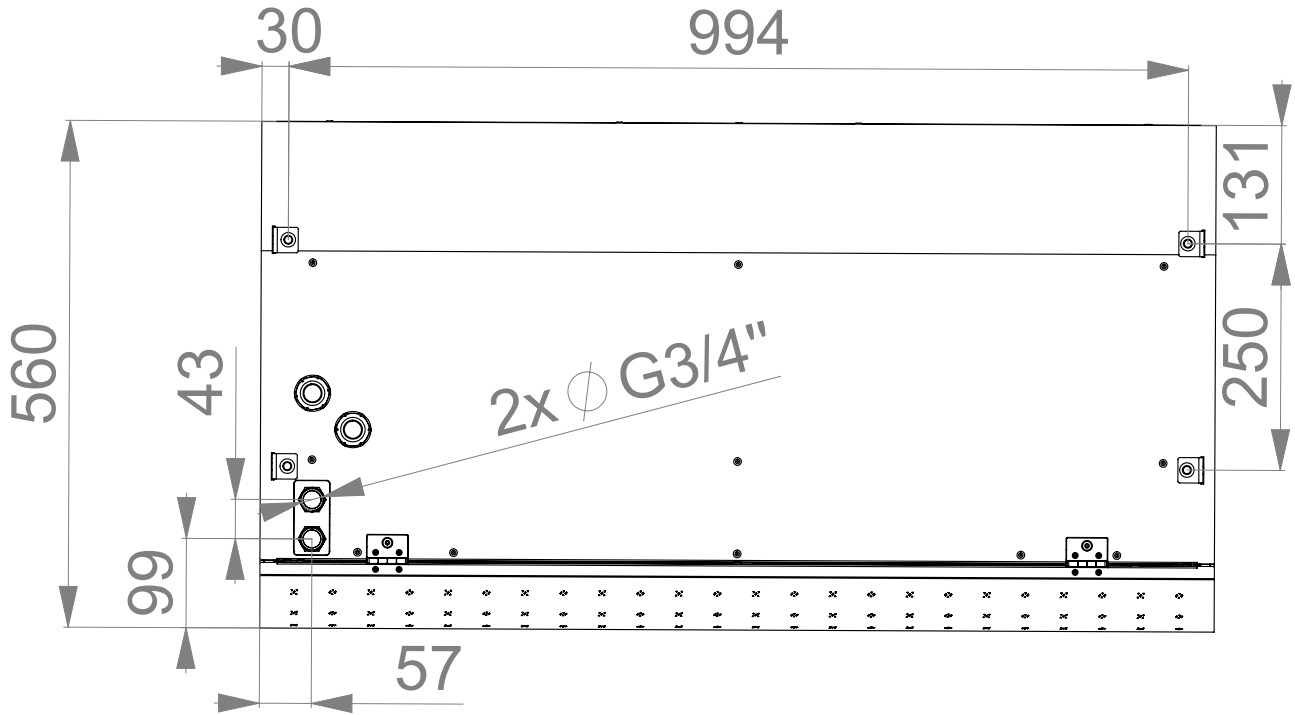

Type	Length [mm]	Width [mm]	Height [mm]
VCST5x100...	994	1054	335
VCST5x150...	1494	1554	
VCST5x-200...	1994	2054	
VCST5x-250...	2394	2454	

## 5. TECHNICAL PARAMETERS

### VCST5 AC

Type	Heater power output [kW]		Total power input [kW] <sup>*1</sup>	Total voltage/ current [V/A]	Motor voltage/ current [V/A]	Temperature increase Δt [°C]	Frequency [Hz]	Weight [kg] <sup>*4</sup>
	1st level	2st level						
VCST5B100-S0AC	-	-	0,65	230/2,85	230/2,85	-	50	44
VCST5B150-S0AC	-	-	1,0	230/4,4	230/4,4	-	50	61
VCST5B200-S0AC	-	-	1,3	230/5,7	230/5,7	-	50	78
VCST5B250-S0AC	-	-	1,6	230/7,0	230/7,0	-	50	95
VCST5B100-E1AC	4,6	9,4	10,3	400/16,6	230/2,85	17,8*	50	48,5
VCST5B150-E1AC	7,6	15,0	16,0	400/26,1	230/4,4	18,05*	50	66
VCST5B200-E1AC	9,8	19,0	20,3	400/33,2	230/5,7	16,84*	50	84
VCST5B250-E1AC	12,5	24,5	26,1	400/42	230/7,0	18,3*	50	102
VCST5B100-V2AC	-	-	0,65	230/2,85	230/2,85	39,5 <sup>*2</sup>	50	50
VCST5B150-V2AC	-	-	1,0	230/4,4	230/4,4	40,6 <sup>*2</sup>	50	67
VCST5B200-V2AC	-	-	1,3	230/5,7	230/5,7	41,5 <sup>*2</sup>	50	85
VCST5B250-V2AC	-	-	1,6	230/7,0	230/7,0	42,0 <sup>*2</sup>	50	99
VCST5C100-S0AC	-	-	0,95	230/4,0	230/4,0	-	50	48
VCST5C150-S0AC	-	-	1,35	230/5,6	230/5,6	-	50	64
VCST5C200-S0AC	-	-	1,7	230/7,0	230/7,0	-	50	80
VCST5C250-S0AC	-	-	2,0	230/8,7	230/8,7	-	50	98
VCST5C100-E1AC	4,6	9,9	10,6	400/17,6	230/4,0	12,5 *	50	53
VCST5C150-E1AC	7,6	15,0	17,0	400/27,5	230/7,0	13,66 *	50	68
VCST5C200-E1AC	9,8	19,0	20,8	400/34,2	230/8,7	13,88 *	50	86
VCST5C250-E1AC	12,5	24,5	26,5	400/44	230/6,9	14,94 *	50	110
VCST5C100-V2AC	-	-	0,95	230/4,0	230/4,0	35,1 <sup>*2</sup>	50	55
VCST5C150-V2AC	-	-	1,35	230/5,6	230/5,6	37,3 <sup>*2</sup>	50	70
VCST5C200-V2AC	-	-	1,7	230/7,0	230/7,0	39,3 <sup>*2</sup>	50	88
VCST5C250-V2AC	-	-	2,0	230/8,7	230/8,7	40,8 <sup>*2</sup>	50	108
VCST5C100-V3AC	-	-	0,95	230/4,00	230/4,00	12,6 <sup>*3</sup>	50	85
VCST5C150-V3AC	-	-	1,35	230/5,60	230/5,60	13,9 <sup>*3</sup>	50	72
VCST5C200-V3AC	-	-	1,70	230/7,00	230/7,00	14,0 <sup>*3</sup>	50	90
VCST5C250-V3AC	-	-	2,00	230/8,70	230/8,70	13,9 <sup>*3</sup>	50	110

\*1 At the maximum air flow and maximum heater power.

\*2 Intake air temperature +18°C, water temperature gradient of 90/70 °C and highest fan speed.

\*3 Intake air temperature +18°C, water temperature gradient of 40/30 °C and highest fan speed.

\*4 Weight with control BASIC / PRIME.

## VCST5 EC

Type	Heater power output [kW]		Total power input [kW] <sup>*1</sup>	Total voltage/ current [V/A]	Motor voltage/ current [V/A]	Temperature increase Δt [°C]	Frequency [Hz]	Weight [kg]
	1st level	2st level						
VCST5B100-S0EC	-	-	0,34	230/2,4	230/2,4	-	50/60	40
VCST5B150-S0EC	-	-	0,50	230/3,4	230/3,4	-	50/60	55
VCST5B200-S0EC	-	-	0,68	230/4,4	230/4,4	-	50/60	70
VCST5B250-S0EC	-	-	0,85	230/5,4	230/5,4	-	50/60	85
VCST5B100-E1EC	4,6	9,4	9,74	400/16,0	230/2,4	14,7	50/60	45
VCST5B150-E1EC	7,6	15,0	15,50	400/25,1	230/3,4	16,0	50/60	60
VCST5B200-E1EC	9,8	19,0	19,68	400/31,9	230/4,4	14,9	50/60	76
VCST5B250-E1EC	12,5	24,5	25,35	400/40,8	230/5,4	15,5	50/60	92
VCST5B100-V2EC	-	-	0,34	230/2,4	230/2,4	38,6 <sup>*2</sup>	50/60	46
VCST5B150-V2EC	-	-	0,50	230/3,4	230/3,4	38,5 <sup>*2</sup>	50/60	61
VCST5B200-V2EC	-	-	0,68	230/4,4	230/4,4	39,6 <sup>*2</sup>	50/60	77
VCST5B250-V2EC	-	-	0,85	230/5,4	230/5,4	40,1 <sup>*2</sup>	50/60	89
VCST5C100-S0EC	-	-	0,50	230/3,3	230/3,3	-	50/60	44
VCST5C150-S0EC	-	-	0,68	230/4,5	230/4,5	-	50/60	59
VCST5C200-S0EC	-	-	0,84	230/5,3	230/5,3	-	50/60	73
VCST5C250-S0EC	-	-	1,20	230/7,2	230/7,2	-	50/60	91
VCST5C100-E1EC	4,6	9,9	9,90	400/16,9	230/3,3	11,6	50/60	50
VCST5C150-E1EC	7,6	15,0	15,68	400/21,2	230/4,5	12,3	50/60	64
VCST5C200-E1EC	9,8	19,0	19,84	400/32,8	230/5,3	10,0	50/60	80
VCST5C250-E1EC	12,5	24,5	25,70	400/42,6	230/7,2	11,4	50/60	104
VCST5C100-V2EC	-	-	0,50	230/3,3	230/3,3	34,5 <sup>*2</sup>	50/60	51
VCST5C150-V2EC	-	-	0,68	230/4,5	230/4,5	34,7 <sup>*2</sup>	50/60	65
VCST5C200-V2EC	-	-	0,84	230/5,3	230/5,3	36,9 <sup>*2</sup>	50/60	81
VCST5C250-V2EC	-	-	1,20	230/7,2	230/7,2	36,1 <sup>*2</sup>	50/60	101
VCST5C100-V3EC	-	-	0,50	230/3,3	230/3,3	12,0 <sup>*2</sup>	50/60	53
VCST5C150-V3EC	-	-	0,68	230/4,5	230/4,5	12,9 <sup>*3</sup>	50/60	69
VCST5C200-V3EC	-	-	0,84	230/5,3	230/5,3	13,2 <sup>*3</sup>	50/60	85
VCST5C250-V3EC	-	-	1,20	230/7,2	230/8,7	13,1 <sup>*3</sup>	50/60	104

\*1 At the maximum air flow and maximum heater power.

\*2 Intake air temperature +18°C, water temperature gradient of 90/70 °C and highest fan speed.

\*3 Intake air temperature +18°C, water temperature gradient of 40/30 °C and highest fan speed.

\*4 Weight with control BASIC / PRIME.

## 6. INSTALLATION

### 6.1 CHOOSE THE INSTALLATION SITE AND INSTALL THE AIR CURTAIN

#### 6.1-1 Built up dimensions

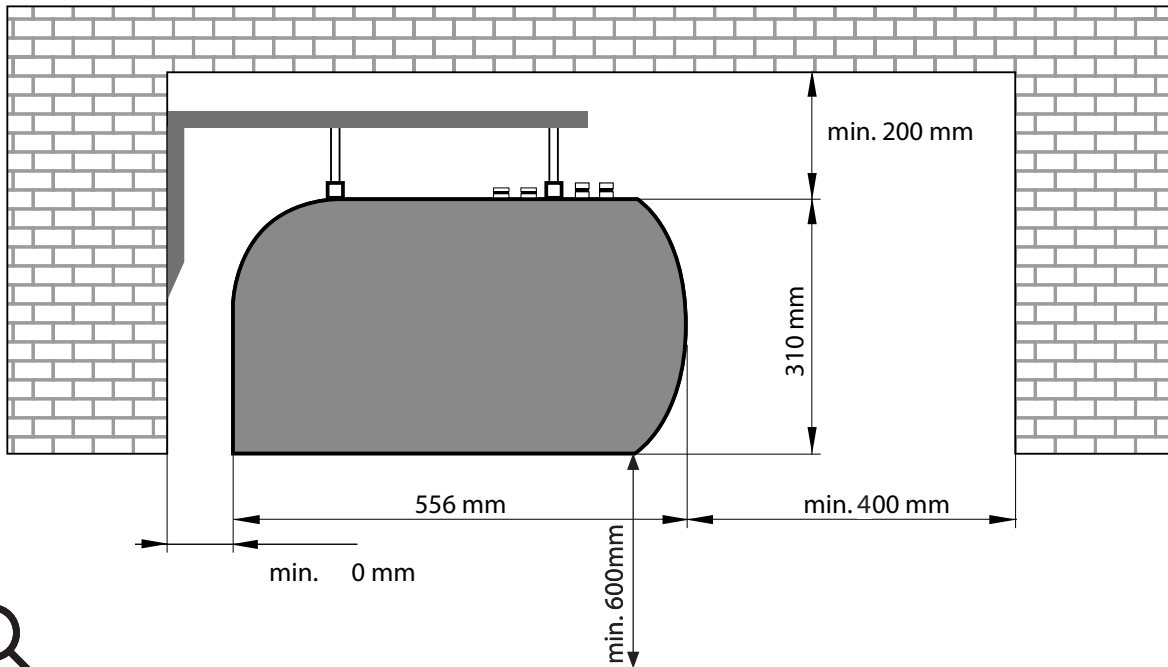

- The air curtain must be installed only in a horizontal position!
- The curtain can be installed over the door opening. All separation distances for flammable materials and safe use of air curtain has to be kept.
- The installed position of the air curtain can be chosen to accommodate the service hood.
- It must be operated in dry, covered indoor spaces with an ambient temperature between +5° C and +40° C and relative humidity up to 80%
- The air curtain is not intended for moving air that contains combustible or explosive mixtures, chemical fumes, coarse dust, soot, grease, poisons, infectious germs, etc.

#### 6.1-2 Clearance distance

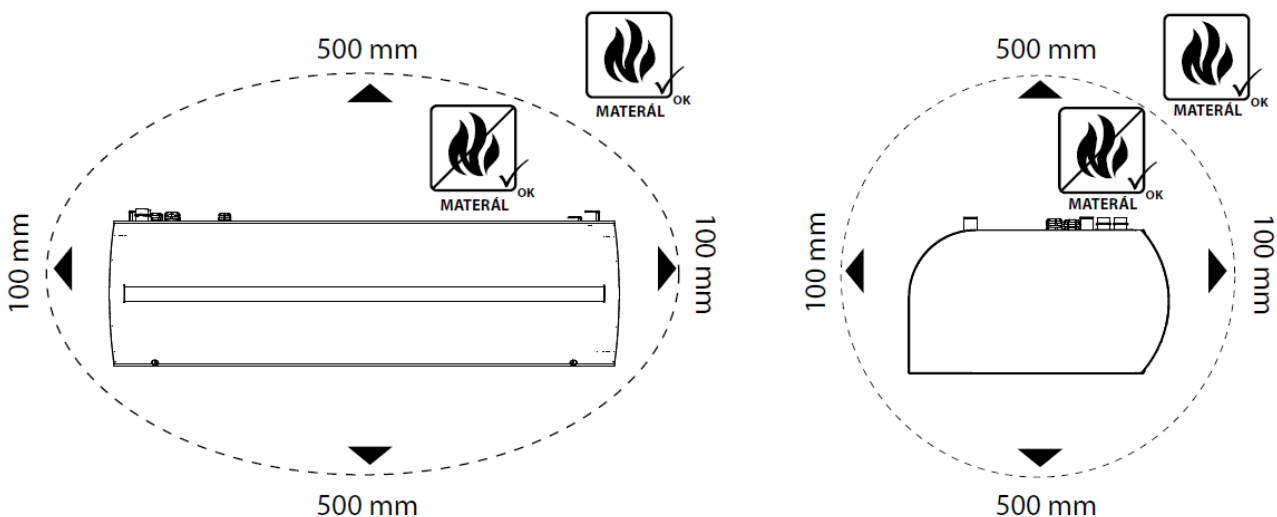

## 6. INSTALLATION

### 6.1-3 Measure the installation site

- Only nonflammable materials (those that do not burn, smoulder or carbonise) or fire-resistant materials (those that do not burn, but mainly smoulder, e.g., plaster board) can be kept within 100 mm in any direction of the air curtain. However, these materials should not block the intake or outlet openings
- For air curtains with an electric heater, safe distances from building structural surfaces and flammable objects are as follows
- The safe distance for flammable materials in the direction of the main air flow (i.e., behind the outlet) is 500 mm
- The safe distance for flammable materials above the air curtain is 500 mm
- The safe distance for flammable materials in other directions is 100 mm.

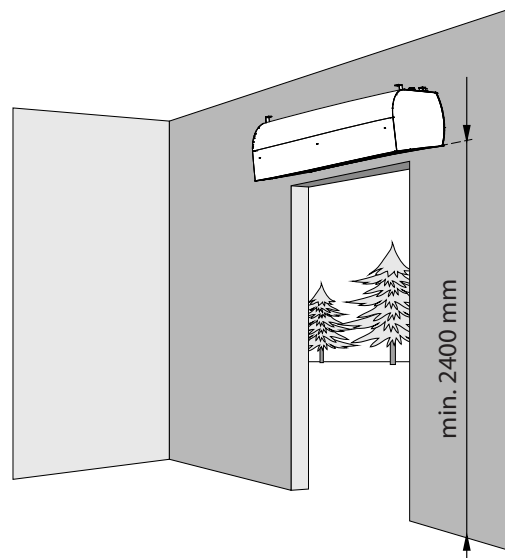
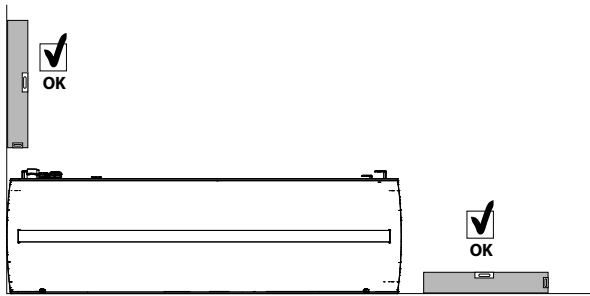

### 6.1-3 Measure the installation site

Choose the location for the installation and measure the installation site. Measure out the dimensions of ceiling installation or for wall mounted brackets.

- It is necessary to ensure proper in the supply at the site according to the exact type of use of the air curtain and based on its electric parameters.
- When using water heated air curtain, please ensure connection of the flow and return pipes.

## 6. INSTALLATION



For wall installation use Wall mounted bracket set: VCS4-KONZ-STE.  
Wall mounted bracket has to be ordered separately as an optional accessory.

Size of bracket VCS4-KONZ-STE

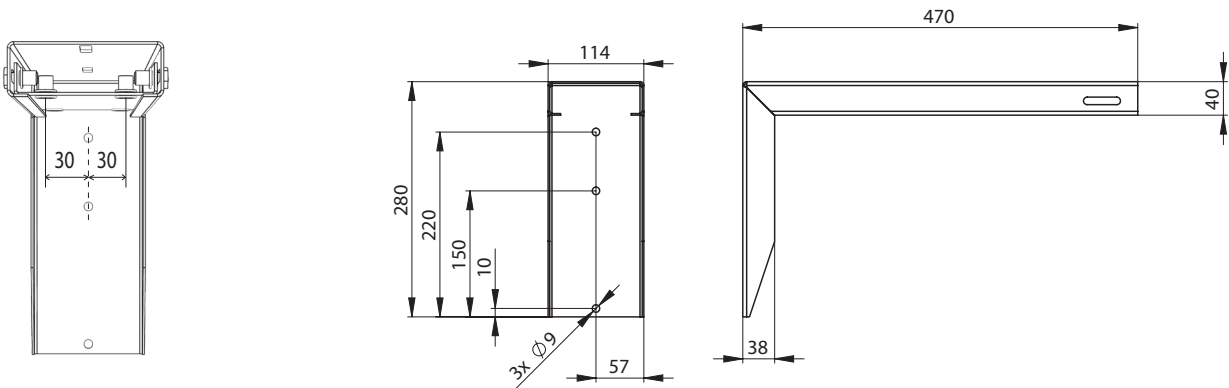

Installation distance

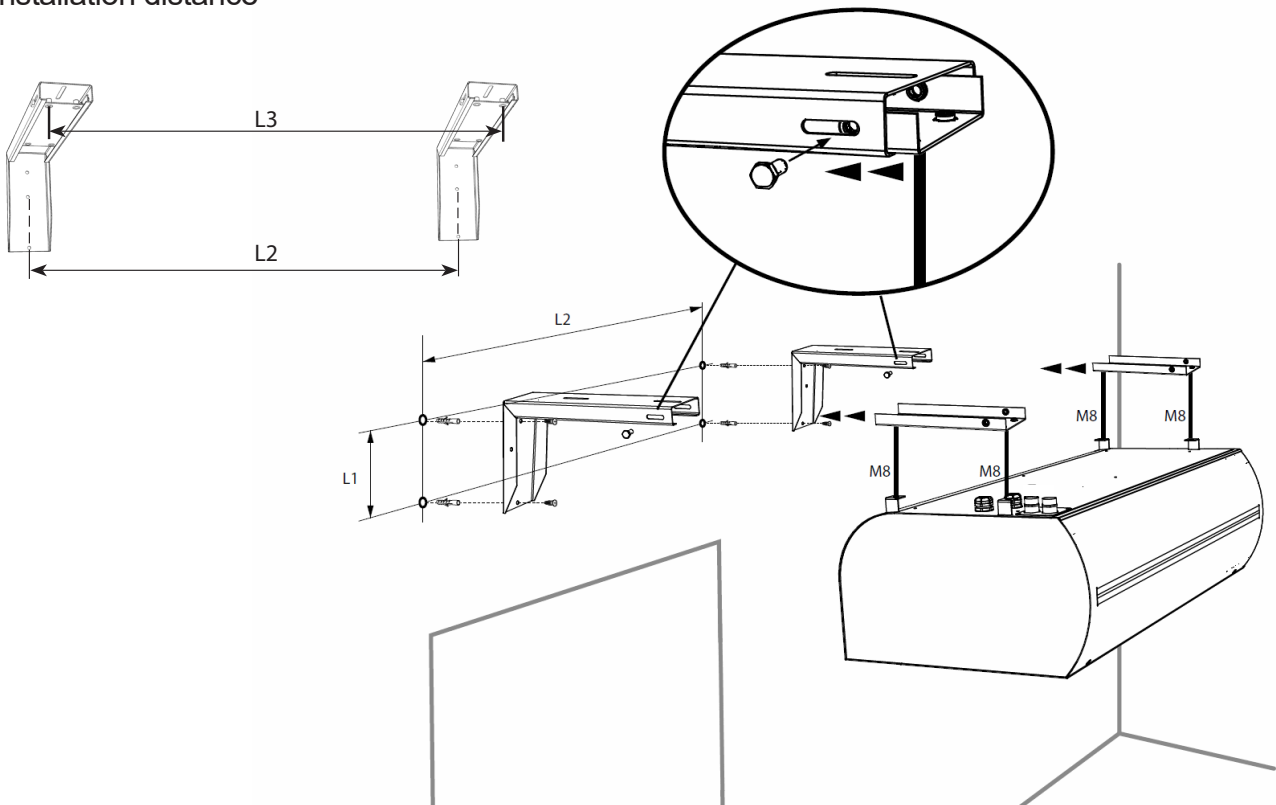

Model	L2 [mm]	L1 [mm]
VCST5x-10x-x..	994	210
VCST5x-15x-x..	1494	210
VCST5x-20x-x..	1994	210
VCST5x-25x-x..	2394	210

## 6. INSTALLATION



For ceiling installation use Ceiling holder SET: VCS4-KONZ-STR. Ceiling holder SET has to be ordered separately as an optional accessory.

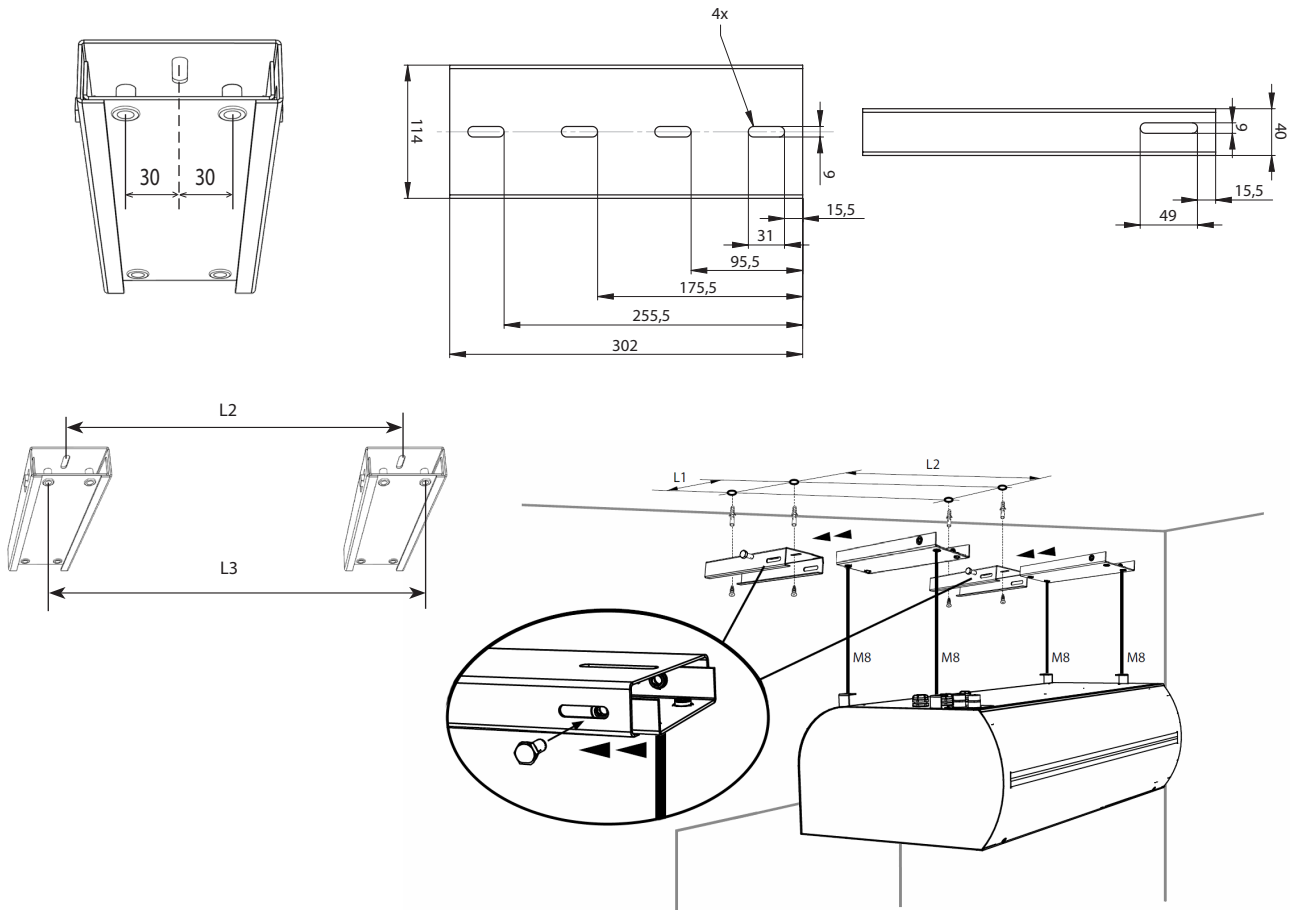

Model	L2 [mm]	L1 [mm]
VCST5x-10x-x..	994	240
VCST5x-15x-x..	1494	240
VCST5x-20x-x..	1994	240
VCST5x-25x-x..	2394	240

### 6.1-4 Suspend the air curtain on the threaded bars and ensure that the suspension will not come loose



- In consideration of the air curtain weight into account, it is necessary to use either a suitable lifting device (forklift, etc.) or use two additional individuals to support it, as long as it is not securely fastened.
- Suspension has to carry the weight of the air curtain!

## 6. INSTALLATION

### 6.2 CONNECT THE WATER INTAKE AND OUTLET HOSES

VCST5x-xxx-V(W)-...



- A flexible hoses with a G3/4" connection



- Connection and pressure testing of the heater must be carried out by a person with professional plumbing knowledge, who must observe current standards and regulations of the given country.
- The maximum water temperature is +100° C. The maximum pressure is 1.6 MPa. We recommend installing a stop valve on the intake and outlet of the heater to allow the water supply to be shut off .

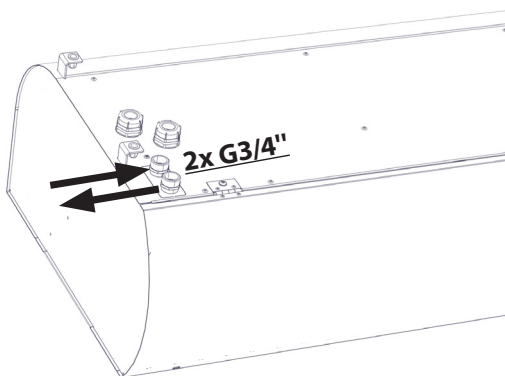

#### 6.2-1 Regulating the water coil with a ZV3-230 or RT zone valve



Zone valve **ZV3-230** is an required accessorie for control module PRIME.  
For air curtain with water heat exchanger and PRIME control module with a jumper between GND and Tx.

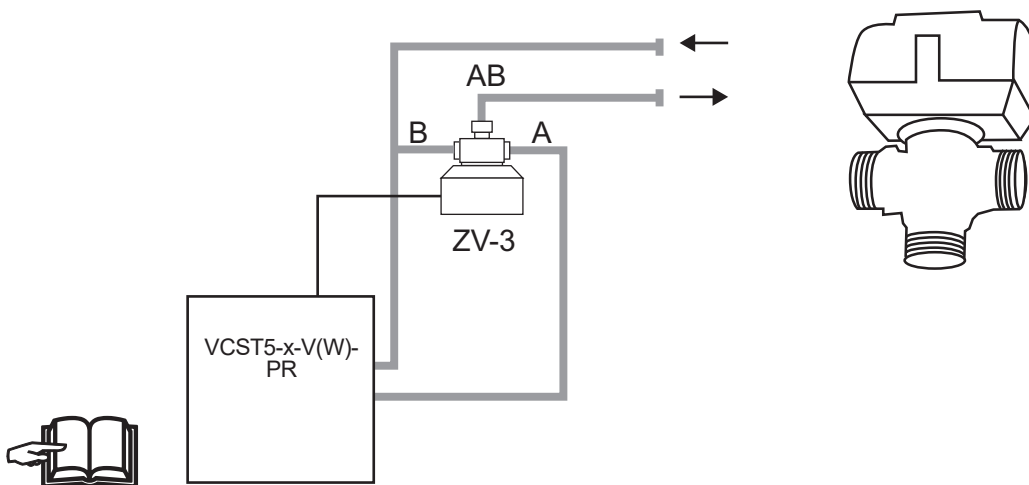

- Detailed description of water coil regulation by zone valve (ZV3-230), including it's connection, refer the instruction manual for zone valve ZV3-230.

## 6. INSTALLATION



Zone valve **RT** is an required accessorie for control module PRIME.  
For air curtain with water heat exchanger and PRIME control module with a jumper between GND and Tx.

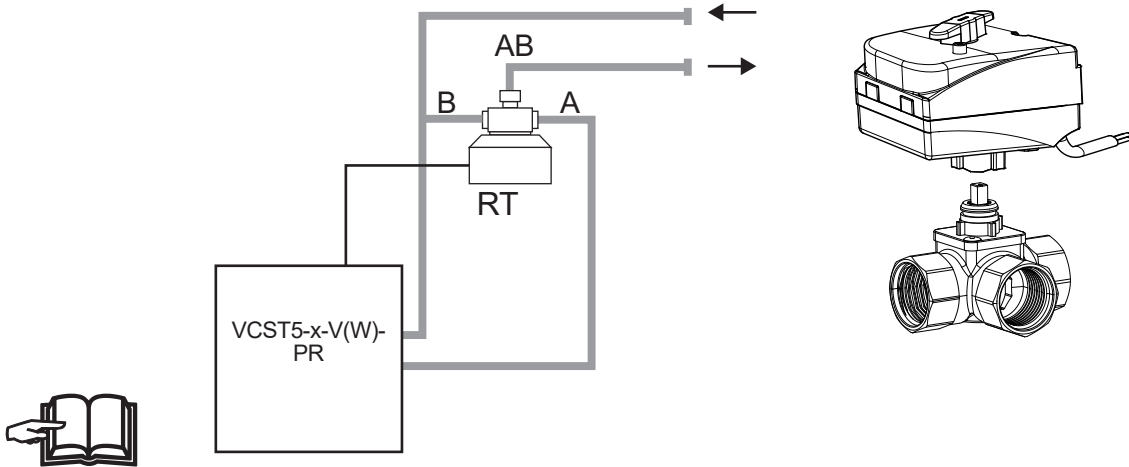

- Detailed description of water coil regulation by zone valve (RT), including it's connection, refer the instruction manual for zone valve RT.



### 6.2-2 Regulating the water coil with an zone valve **ZV3-24V**.



Zone valve **ZV3-24V** is an required accessorie for control module PRIME.  
Zone valve for air curtain with water heat exchanger and PRIME control module without GND to Tx connection.  
Supply 24 V/ 50/60 Hz, control tension 0-10V

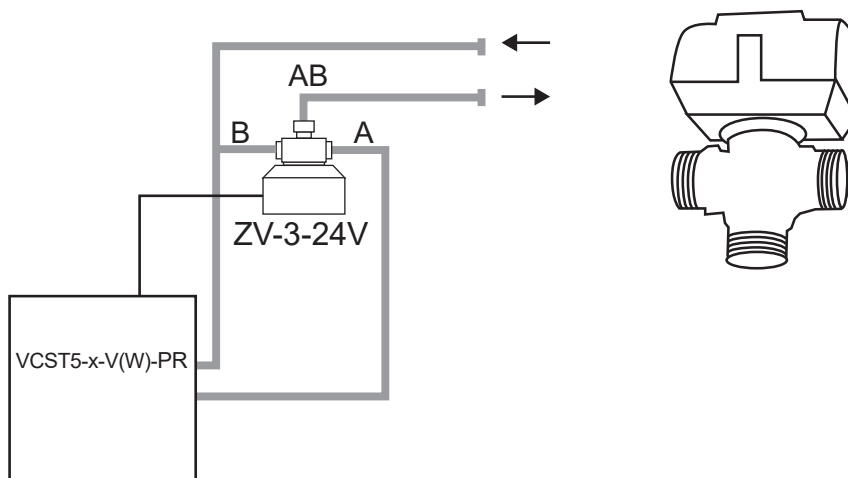

Detailed description of water coil regulation by zone valve (ZV3-24V), including it's connection, refer the instruction manual for zone valve ZV3-24V.

## 6. INSTALLATION

### 6.3 ELECTRO INSTALLATION



- The air curtain's electrical connection must be based on a professional design by a qualified electrical systems engineer.
- Installation must be carried out by a professionally trained electrical worker. All applicable national regulations and directives must be observed.
- The electrical schematics on the product take priority over those presented in this manual!
- Prior to installation, check to see if the terminal markings correspond to the markings on the electrical connections diagram. When in doubt, contact your supplier and do not connect the air curtain under any circumstances.
- Never reach inside the air curtain unless the main electrical supply has been turned off !
- If the product is connected to any control system other than the original one, the regulation and measurement components must be connected by the company that supplied the system.
- The electrical contractor defines the minimum size of the feed cable according to the standards applicable at the place of installation, the location for installing the cable, the surrounding conditions, and the curtain's technical parameters.



**Special attention should be paid to the capacity of the distribution network of the air curtain with electric heater in terms of the supply of the appropriate phase current values for limiting the voltage fluctuations and flickering in the network.**

**The minimum cable dimensions must be used in accordance with the technical values indicated on the product label and in accordance with the applicable laws and regulations of the country.**

Fuse specification:

VCST5-x-xxx...		x	
		B	C
xxx	100	3,15A	5A
	150	4A	6,3A
	200	6,3A	8A
	250	8A	12A

## 6. INSTALLATION

VCST5-xxx-S / V

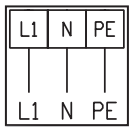

VCST5-xxx-E

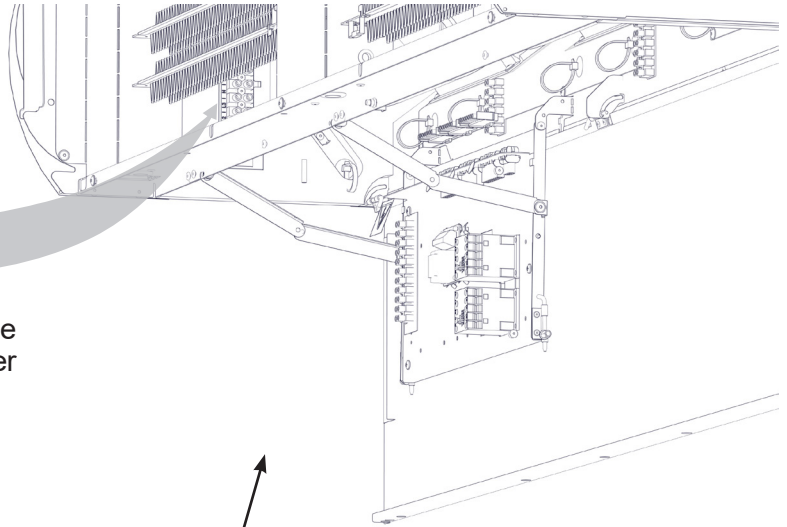
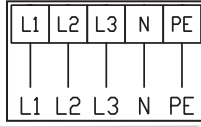

The electrical parameters are shown on the manufacturer's label, which is located under the air curtain's service cover.

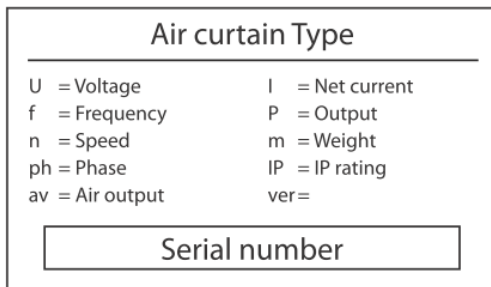

Motors and board fuse  
5x20  
250V AC  
T<sub>xx</sub>A

- The air curtain must be protected by an appropriate circuit breaker, in accordance with its electrical parameters. For safety reasons, over-designed protection is not recommended.
- The air curtain must be connected using the TN-S system, which means that the neutral conductor must always be connected.
- A main cut-off switch must be placed in the electrical supply network, disconnecting all poles of the network.
- The electrical enclosure of the air curtain is IP 20.



FINESSE air curtains are equipped with a fuse (with T characteristic – slow-blow). This safety fuse protects the electronic panel and fans. It is located under the service cover next to the main power supply connectors.

### 6.4 CONNECTION THE CONTROL PANEL

Unscrew the screws and open the regulation cover

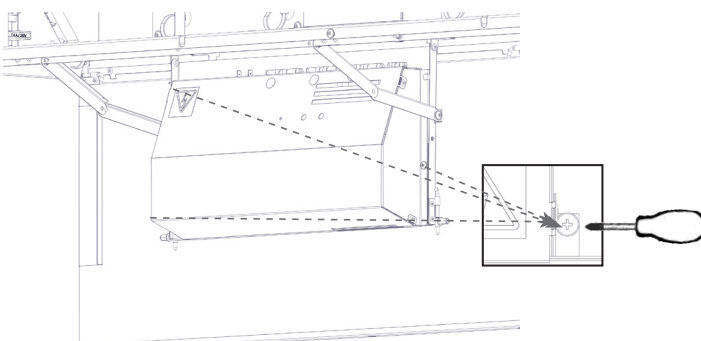

## 6. INSTALLATION

### 6.4 PLACEMENT AND CONNECTION OF THE CONTROL PANEL



The controller shows error messages that are important for the functionality and operation of the device, therefore the controller must always be placed in a visible location.

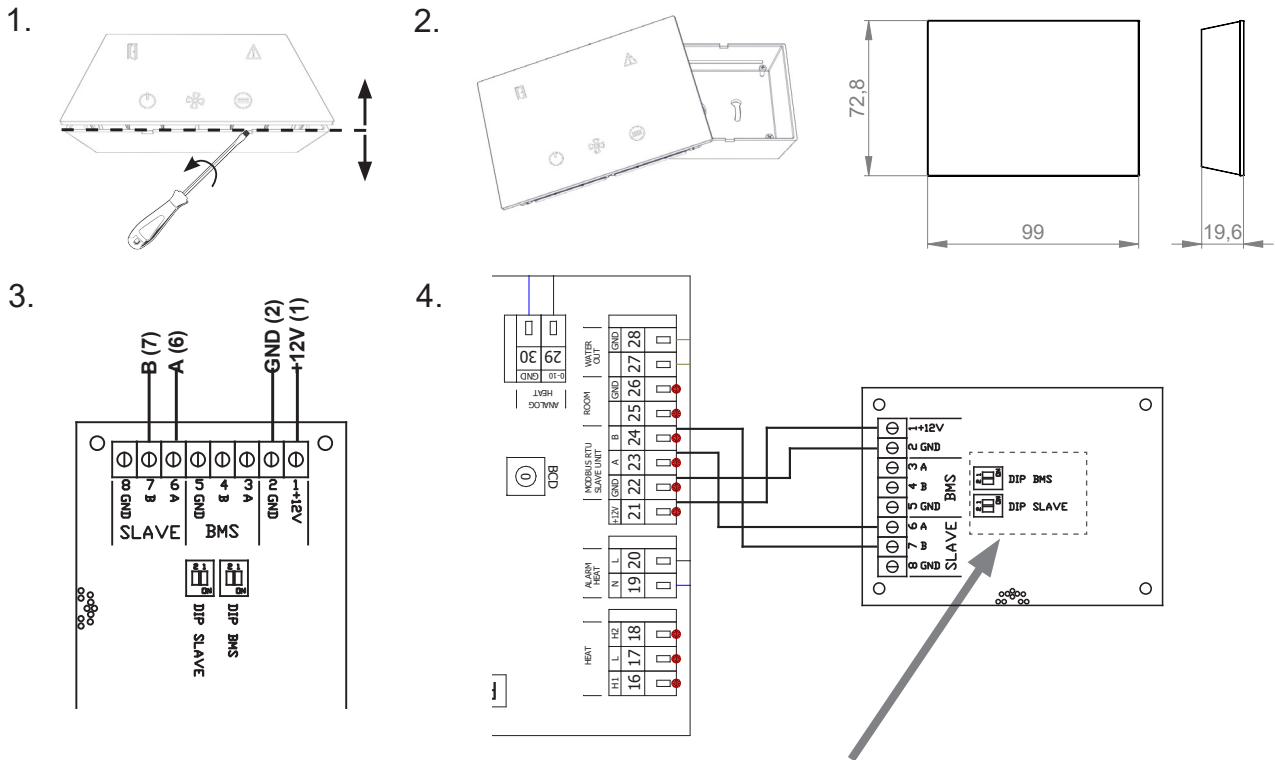

**Important to use UTP CAT5 data cable (plugged crossed pair)!!!**



**DIP BMS – termination possibilities:**

- DIP1 and DIP2 set to OFF – not terminated BUS
- DIP1 and DIP2 set to ON – BUS termination 150Ω
- DIP1 set to ON and DIP2 set to OFF – BUS termination 300Ω
- DIP1 set to OFF and DIP2 set to ON – BUS termination 300Ω
- Default:** DIP1 – ON, DIP2-OFF - BUS termination 300Ω

**DIP SLAVE -** In case of set DIP to ON, termination

- DIP1 and DIP2 set to OFF – not terminated BUS
- DIP1 and DIP2 set to ON – BUS termination 150Ω
- DIP1 set to ON and DIP2 set to OFF – BUS termination 300Ω
- DIP1 set to OFF and DIP2 set to ON – BUS termination 300Ω
- Default:** DIP1 – ON, DIP2-OFF - BUS termination 300Ω

### 6.5 CONNECTION TO MODBUS RTU

Modbus RTU connection to the control panel

Range of settings:

Modbus address: 1-247, Default: 1

Baudrate: 4800/9600/19200/38400, Default:9600

Parity: NONE/ODD/EVEN

Default: ODD

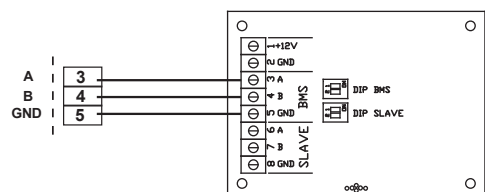

See the Modbus Connection Guide for more information.

# 6. INSTALLATION

## 6.6 CONNECTION OF ACCESSORIES

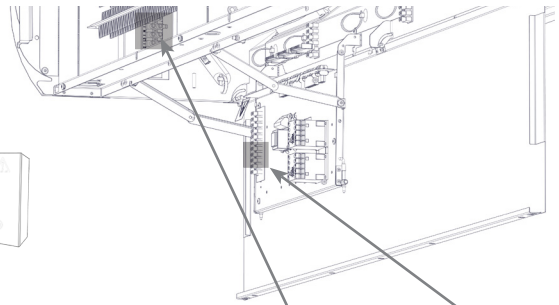

**AirGENIO PRIME AC/EC MASTER**

Electric heater	Air-only	Water heater
L1 L2 L3 N PE	L1 N PE	L1 N PE
L1 L2 L3 N PE	L1 N PE	L1 N PE

IN CONTROL MODULE  
0-10V +24V GND **10**

1	External control - (input, ON/OFF)
2	Room Thermostat (input, NO/NC)
3	DOOR contact (input, NO/NC)
4	SLAVE unit connection
5	Outside air sensor (not included in delivery)
6	Antifreeze for water version
7	Room sensor (not included in delivery)
8*	ERROR or HEAT2
9**	Water valve control ON/OFF or RUN
10	Water valve control (0-10V)

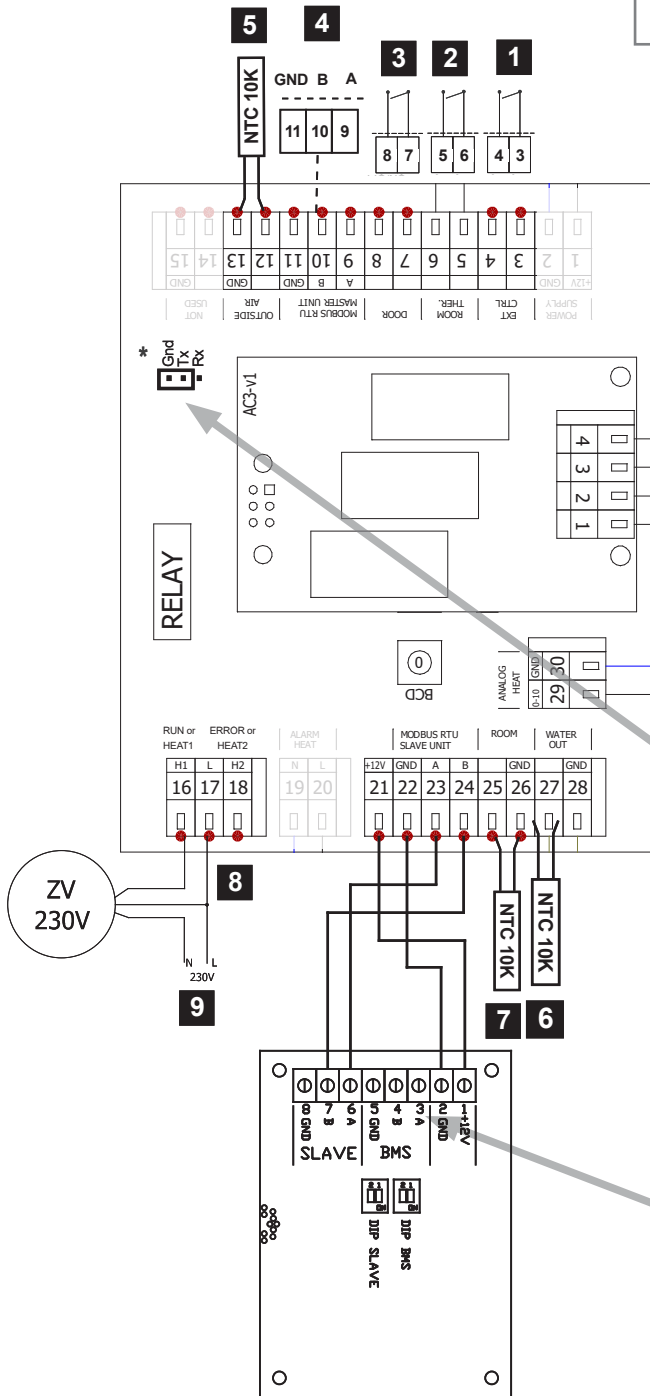

\*RUN/ERROR available without jumper between GND and Tx.

\*\* For ON/OFF water valve control it is necessary to connect the jumper between GND and Tx.

**0-10V - set as default output for whater heating control.**

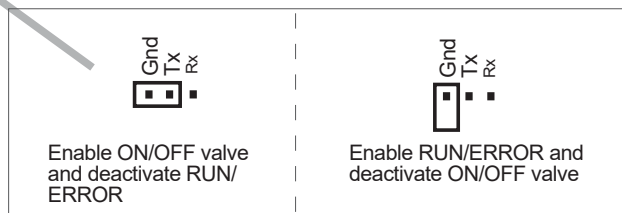

Modbus RTU  
(A - 3, B - 4, GND - 5)

To connect the controller with the unit control, we recommend using a shielded cable such as UTP CAT5. The maximum recommended cable length is 40m!

**CONTROL PANEL - MASTER**

# 6. INSTALLATION

## 6.6 CONNECTION OF ACCESSORIES

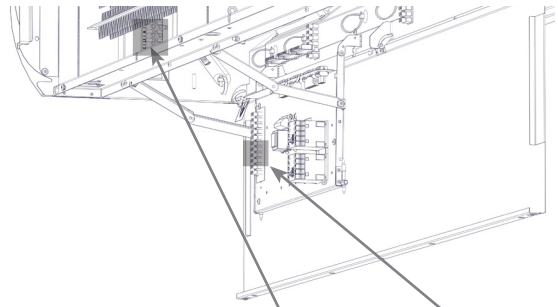

**AirGENIO PRIME AC/EC SUBUNITS**

Electric heater	Air-only	Water heater
L1 L2 L3 N PE	L1 N PE	L1 N PE
L1 L2 L3 N PE	L1 N PE	L1 N PE

IN CONTROL MODULE  
0-10V +24V GND  
**7**

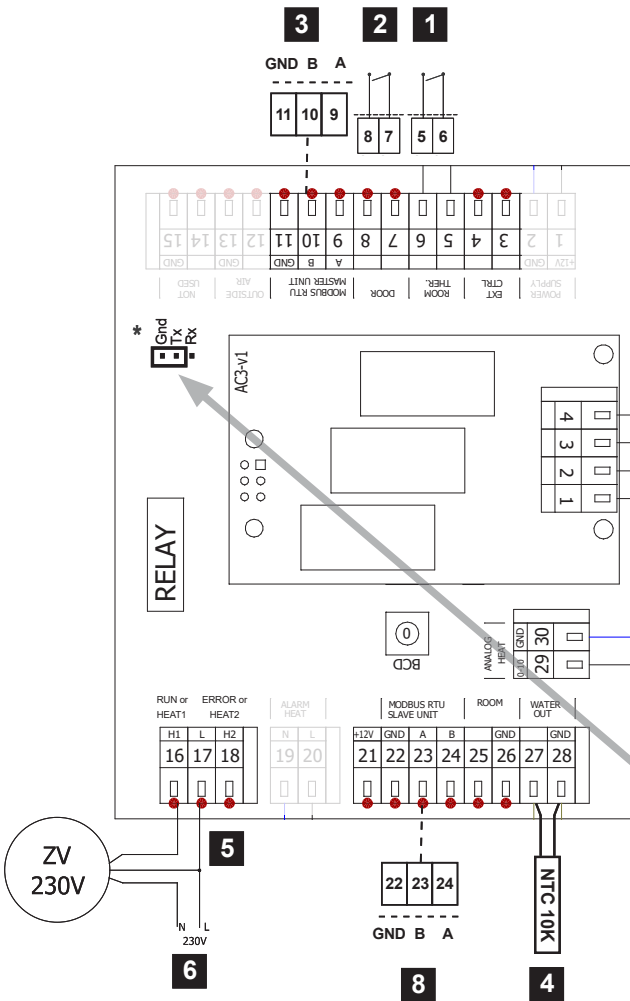

1	Room Thermostat (input, NO/NC)
2	DOOR contact (input, NO/NC)
3	SLAVE unit connection
4	Antifreeze for water version
5*	ERROR or HEAT2
6**	Water valve control ON/OFF or RUN
7	MASTER unit connection
8	Water valve control (0-10V)

\*RUN/ERROR available without jumper between GND and Tx.

\*\* For ON/OFF water valve control it is necessary to connect the jumper between GND and Tx.

**0-10V - set as default output for water heating control.**

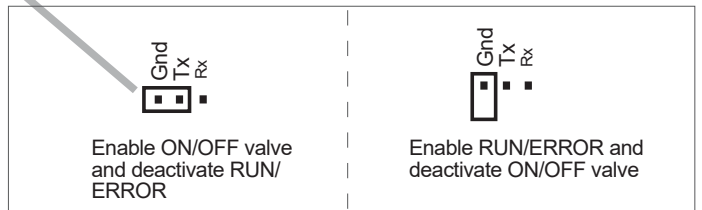

## 6. INSTALLATION

### 6.7 ELECTRICAL SCHEMES CHAINING



Use a shielded UTP communication cable (included in delivery) for chaining.

**The data communication cable must be separated from the power line cables.**

Connect communication terminals A , B and GND on both boards (SLAVE - SLAVE).

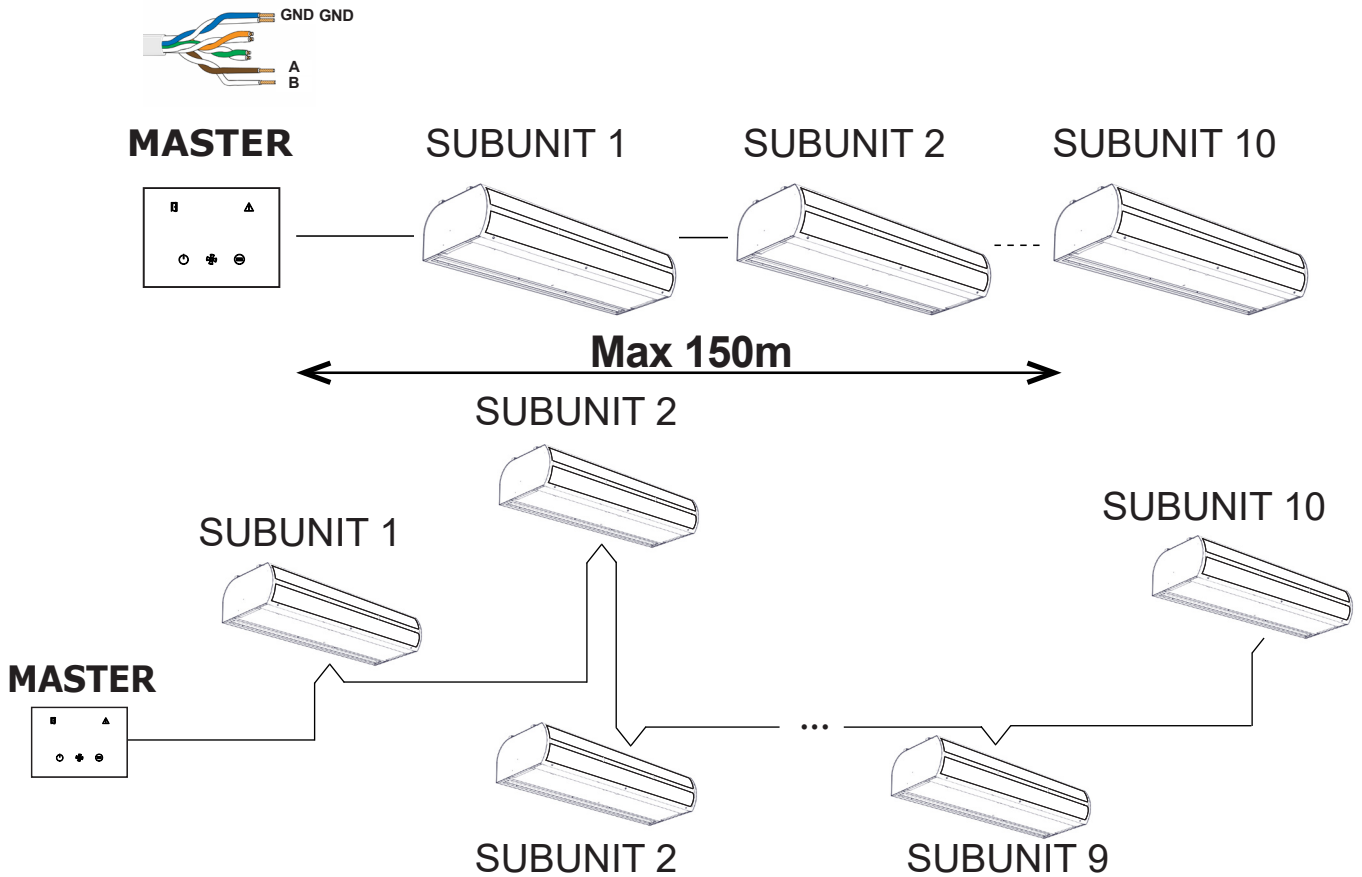

To configure the MASTER-SLAVE terminal resistance, refer to the specifications of the specific device bus and correctly set the resistances at the ends of the device on the bus.

Correct termination is important for the proper functioning of communication buses.

DIP position



Version with jumper on the PCB

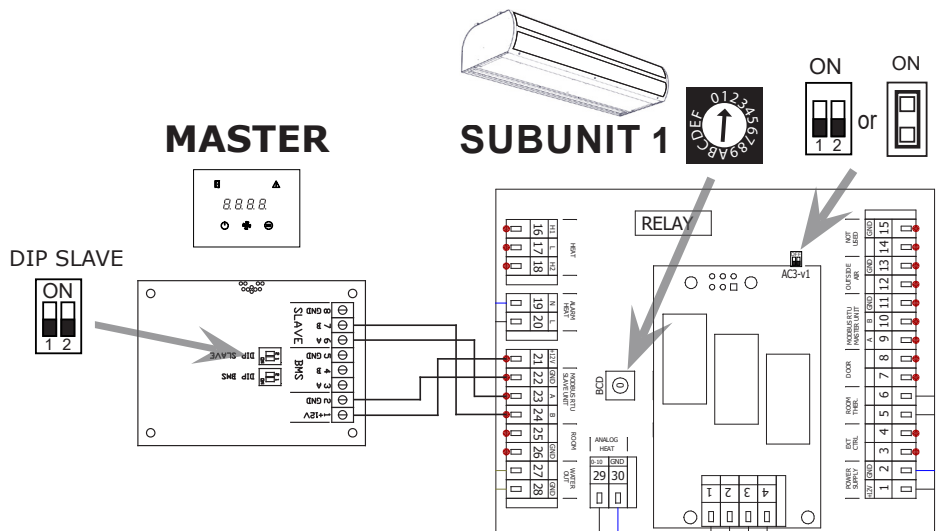
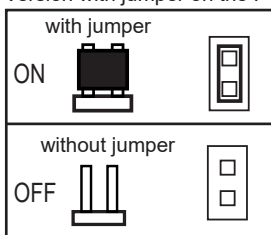

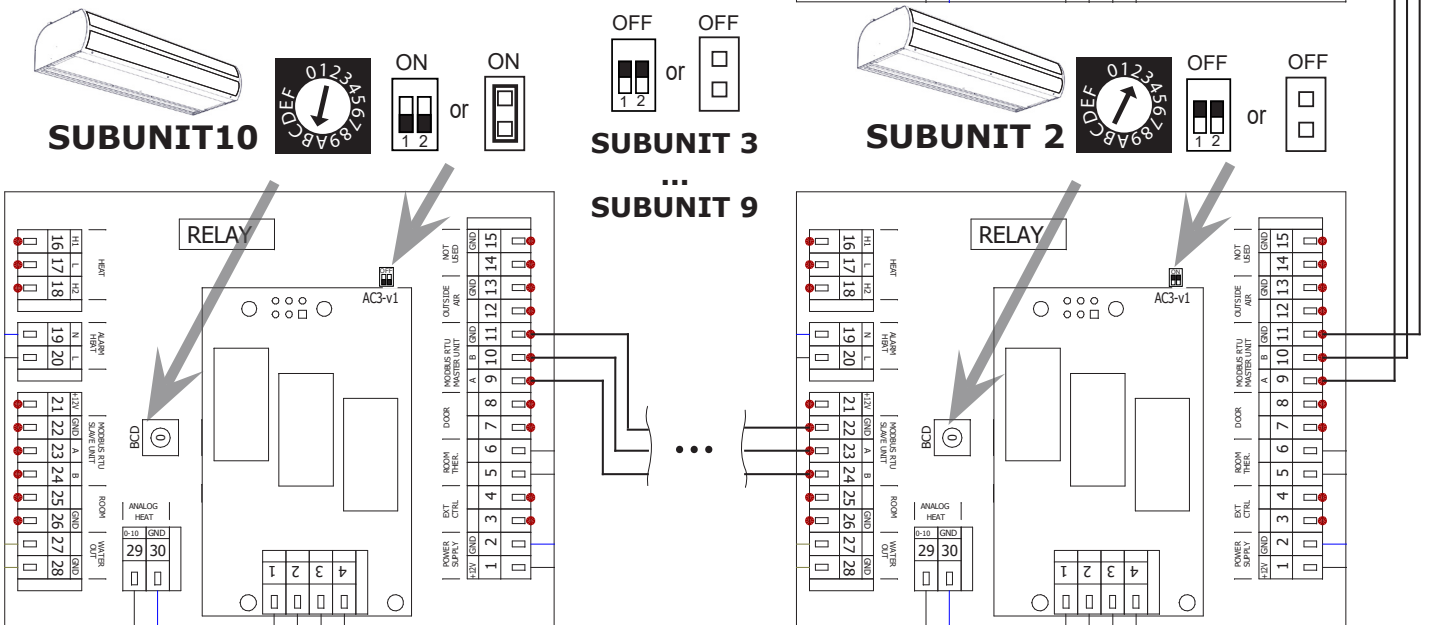
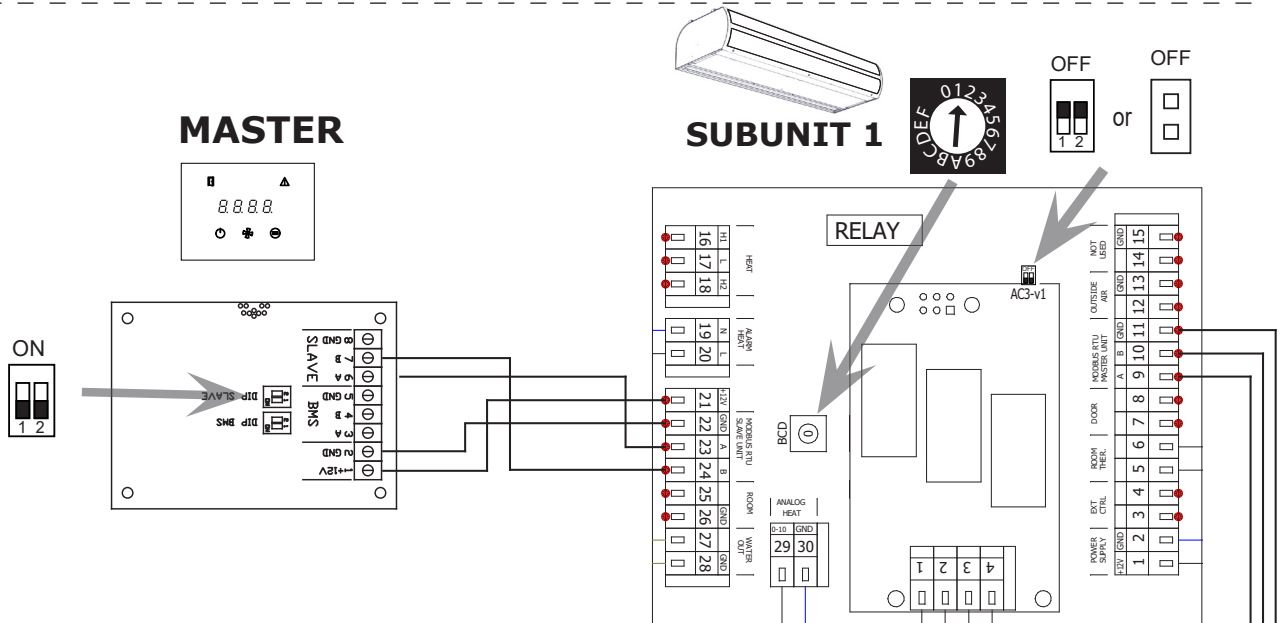
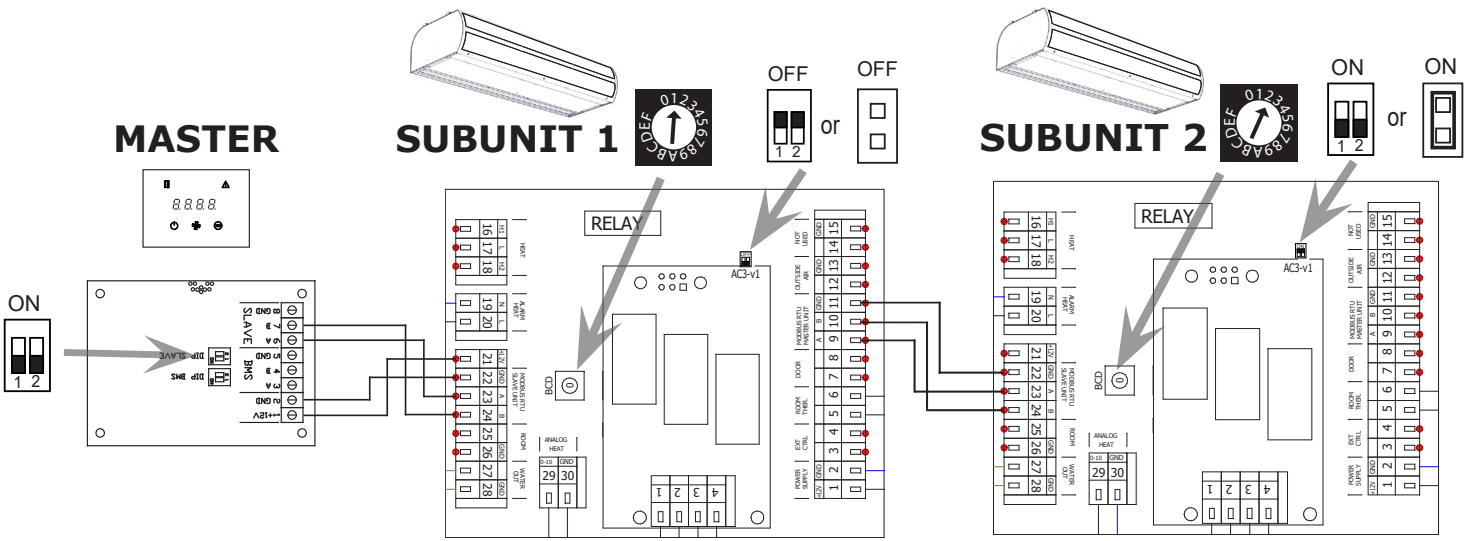

## 6. INSTALLATION

### CONNECTING EXTERNAL ACCESSORIES

#### PLEASE NOTE

- The unit must be disconnected from the power supply to connect accessories.
- All external control components must be connected according to the wiring diagram.

### 6.8 TEMPERATURE SENSORS

#### Included temperature sensors

Room temperature sensor - located in the control panel.

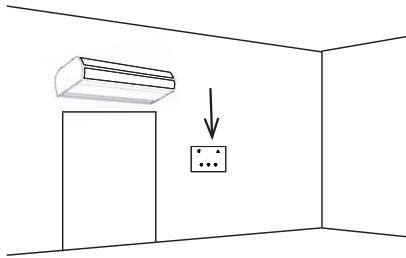

The return water temperature sensor.

WATER OUT	
GND	
27	28

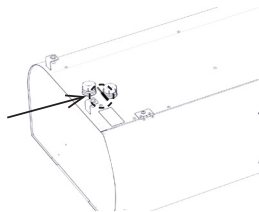

#### Option temperature sensors (not included)

Outside temperature sensor.

OUTSIDE AIR	
GND	
12	13

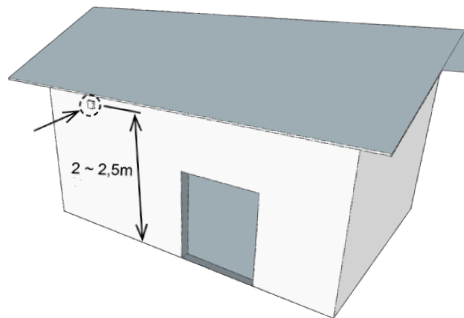

	<p>Outside temperature sensor is recommended to be installed on North side of building, protected against direct sunlight or any other unwanted heat radiation.</p>
	<p>Temperature sensor is recommended to install to an cover box, which should contain small hole for better results.</p>

Room temperature sensor

After installing a room temperature sensor on terminals 25-26, the temperature sensor in the control panel is automatically deactivated.

ROOM	
GND	
25	26

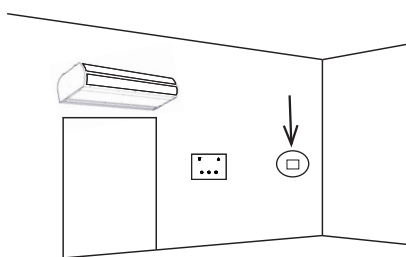

## 6. INSTALLATION

### 6.9 EXIT SIGN



- Exit sign marking of emergency exit



**Not included in delivery.**

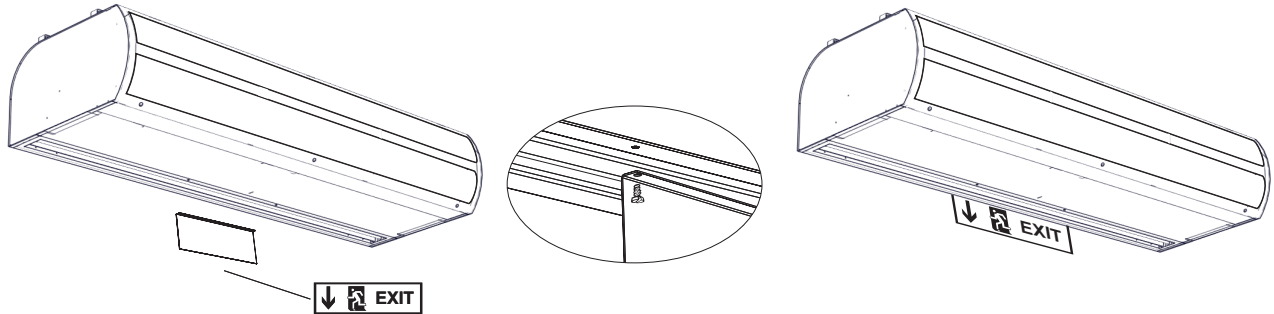

### 6.10 COVERING THE AIR CURTAIN + FILTERS

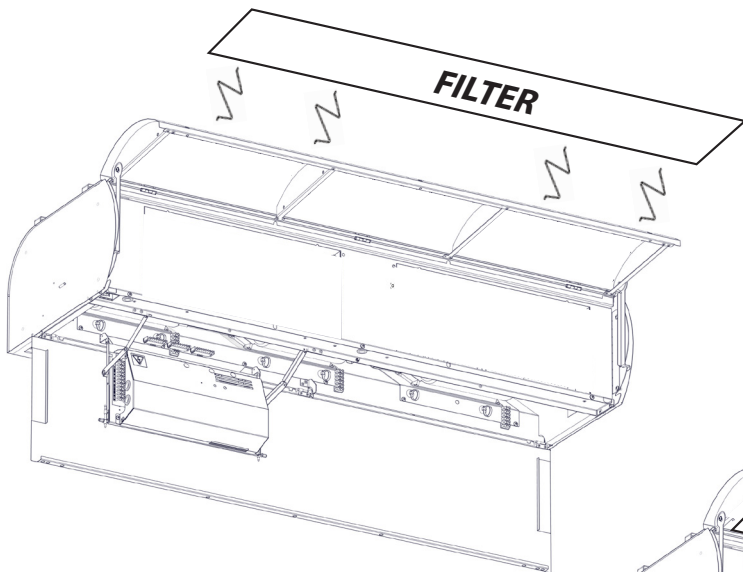

**NUMBER OF SPRINGS DEPENDING  
ON THE LENGTH OF THE UNIT**

1m - 2 pcs  
1,5m - 3 pcs  
2m - 4 pcs  
2,5m - 4 pcs

**Do not use with the electric  
version!!**

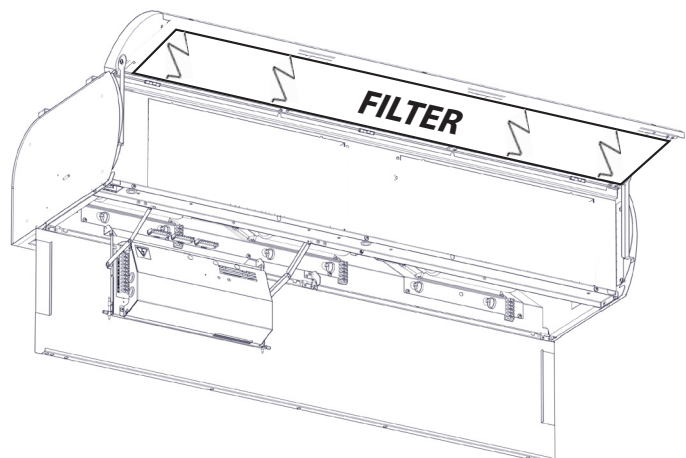

## 8. COMMISSIONING

### **PLEASE READ CAREFULLY!**

#### **Before the initial commissioning, check:**

- that the device is well fastened to the support structure,
- that the device is properly closed
- that the power supply is properly connected, including the earthing and the external trigger protection,
- that all the electrical components are securely connected,
- that the installation complies with all the instructions herein,
- that no tool or any other object that may damage the unit remains within.

### **CAUTION!**

- Interventions or changes to the internal connections are forbidden and shall result in the loss of warranty.
- We recommend the use of accessories supplied by our company. Contact your supplier in case of doubts regarding the use of non-original accessories.

### **START-UP**

After connecting power supply, the display lights up and the data is loaded.

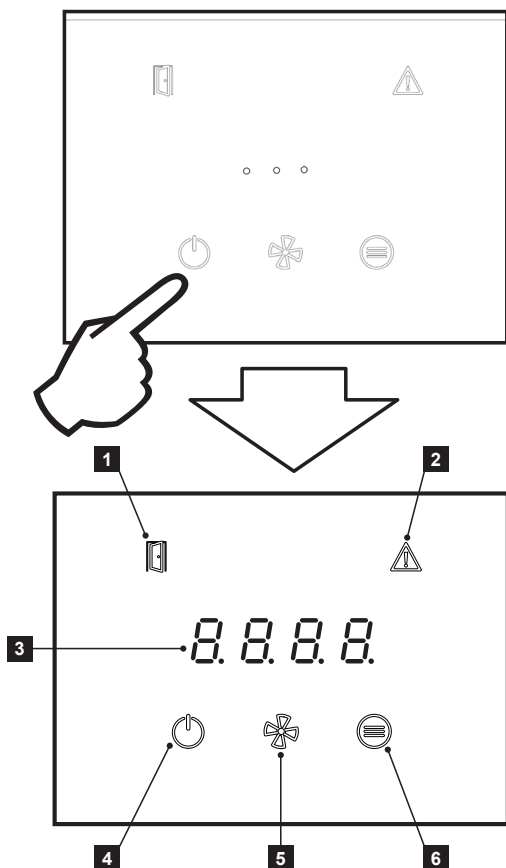

The device is started and switched off by pressing the ON/OFF symbol for two seconds

- 1 - Open door status icon
- 2 - Error signalization
- 3 - Semi-segment display
- 4 - ON/OFF button (hold 2 secs.)
- 5 - Speed control button
- 6 - Temperature settings

**Full description is available in the PRIME OPERATIONAL MANUAL**

## INDICATION ON THE PRIME CONTROL PANEL

- The LED above the button lights up - button press evaluated.
- ON/OFF LED flashes - time switch mode is active.
- FAN LED flashes - aftercooling is active.
- HEAT LED flashing - heating output limited due to insufficient airflow (electric version only), flashes only 20 seconds after HEAT button is pressed.
- Door LED lights - door is open
- LED Door flashes - Doo mode active
- ERROR LED lit - ERROR indication or freeze protection active. And at the same time the display shows an error code when the air curtain is in ON mode. In standby mode, only the ERROR LED remains lit.

### LIST OF ERROR CODES:

**E70 - WATER HEATER ANTIFREEZE PROTECTION**  
**E80 - MODBUS GATEWAY COMMUNICATION FAILURE**  
**E65 - COMMUNICATION FAILURE**  
**E44 - FAN FAILURE**  
**E45 - MAINTANANCE NEEDED/CLOGGED AIR FILTER**  
**E52 - MAINTANANCE SOON NEEDED/AIR FILTER CLOGGED > 80%**  
**E46 - HEATER ERROR**  
**E61 - ROOM TEMPERATURE SENSOR FAILURE**  
**E63 - ROOM BMS TEMPERATURE SENSOR FAILURE**  
**E62 - OUTSIDE BMS TEMPERATURE SENSOR FAILURE**  
**E47 - OUTSIDE TEMPERATURE SENSOR FAILURE SLAVE1**  
**E81 - ROOM TEMPERATURE SENSOR FAILURE SLAVE1**  
**E60 - WATER OUTLET TEMPERATURE SENSOR FAILURE**  
**E82 - TACHO STATE ERROR**  
**E97 - SHORT CIRCUIT BTN**  
**E98 - MISSING SPI COMMUNICATION WITH ESP WIFI MODULE**  
**E99 - CFG ERROR**

### AUTOMATIC FAN SPEED CONTROL INDICATION:

If the FAN button is pressed in the automatic fan speed control, the display shows the warning "Auto" for about 3 seconds, and in the next 3 seconds the current fan speed is displayed (e.g. "F 33" for 33% fan speed)

### Interruption of time switch mode from control panel:

Press ON/OFF – display shows "t. oFF" - timer OFF)

(Reactivation of interrupted time switch mode, is available from APP AirGenio PRIME by disabling and again enabling time switch mode usage)

### BUTTON FUNCTIONS:

**ON/OFF**

Short press button ON/OFF – escape or enter (according to actual position in the menu)

Long press button ON/OFF – ON/OFF or time switch mode interruption

6 short presses in rapid succession (double-click on the button) - activate the remote-control lock if the lock code is set in APP AirGenio PRIME

**FAN**

fan speed selection / fan speed info or setting tens when entering the controller lock code.

**HEAT/Function button**

heating power or desired ROOM temperature selection/ info of the set heating power or current ROOM temperature or setting unit when entering controller lock code.

### RESET maintenance/filter timer

To reset the maintenance/filter timer in the off state, press the fan button 3 times and then the HEAT/FUNCTION button 3 times. A successful reset is indicated by the clr message.

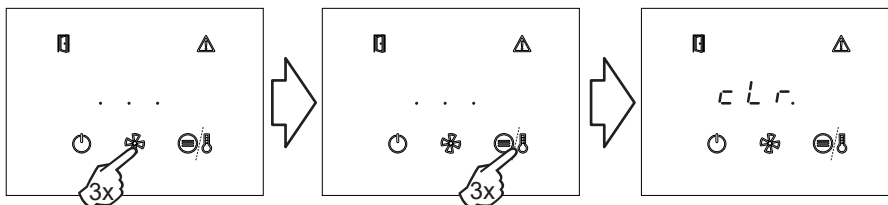

## 10. SERVIS

### 10.1 RESETTING THE EMERGENCY THERMOSTAT

The main electrical supply must be switched off before any tampering with the inside of the air curtain. The air curtain must be allowed to cool down!

- Clean the surface and the inside of the air curtain, including the intake section.
- Visual inspection of the orifice, heating exchanger and wiring.
- Check of emergency thermostats and subsequent reset.

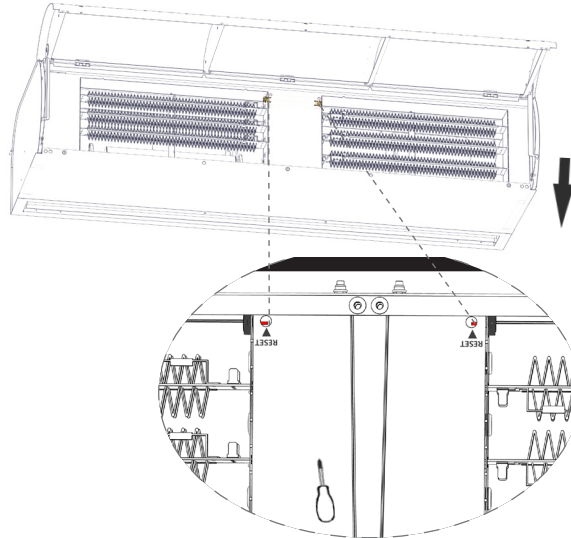

### 10.2 WHEN YOU AREN'T ABLE TO REMOVE DEFECT BY YOURSELF

If you are unable to resolve the problem, contact the supplier.  
For the fast removal of defects please provide the following information:

- product reference number
- serial number
- running time
- used accessories
- installation location
- installation condition (including electrical)
- detailed description of the problem and the steps that you have taken for its removal

Warranty and post-warranty service is performed by the manufacturer, supplier or authorized service organization. When ordering service intervention it is necessary to describe the defect, product type designation indicated on its label, and the location of installation.

### PUTTING THE PRODUCT OUT OF OPERATION - DISPOSAL

Before disposing of the product, make the product unusable. Even old products contain raw materials that can be reused. Take them to a collection point of secondary raw materials.

The product is good to dispose at the place, which is specialized for it, and thus it will be possible to recycle materials. Store unusable parts of the product at a controlled dump.



When disposing of materials, it is necessary to observe the relevant national regulations on waste disposal.

# 11. ELECTRICAL SCHEMES

## VCST5B-100/150/200-S0-AC-PR (without heater)

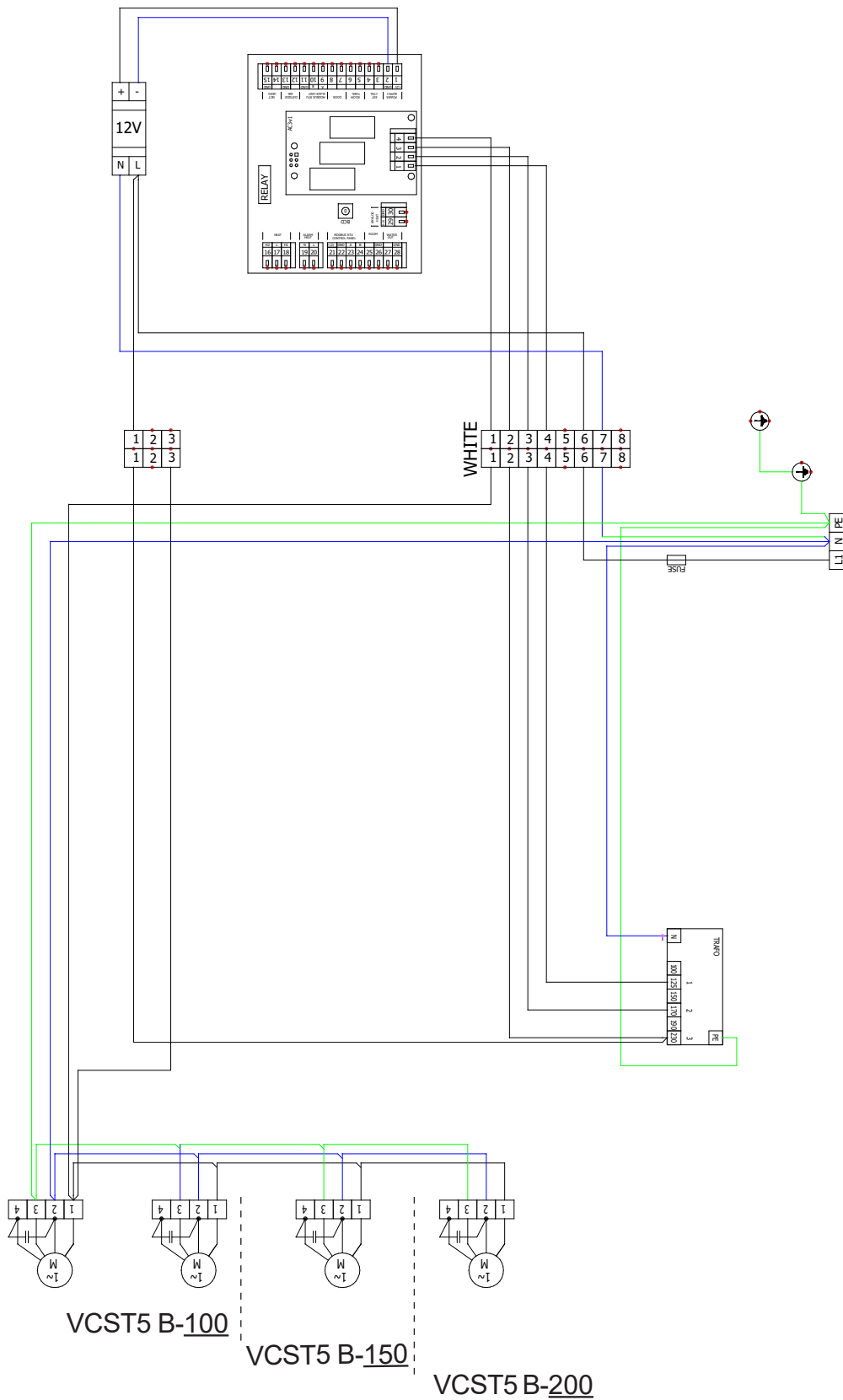

AC fans

# 11. ELECTRICAL SCHEMES

## VCST5B-250-S0-AC-PR (without heater)

AC fans

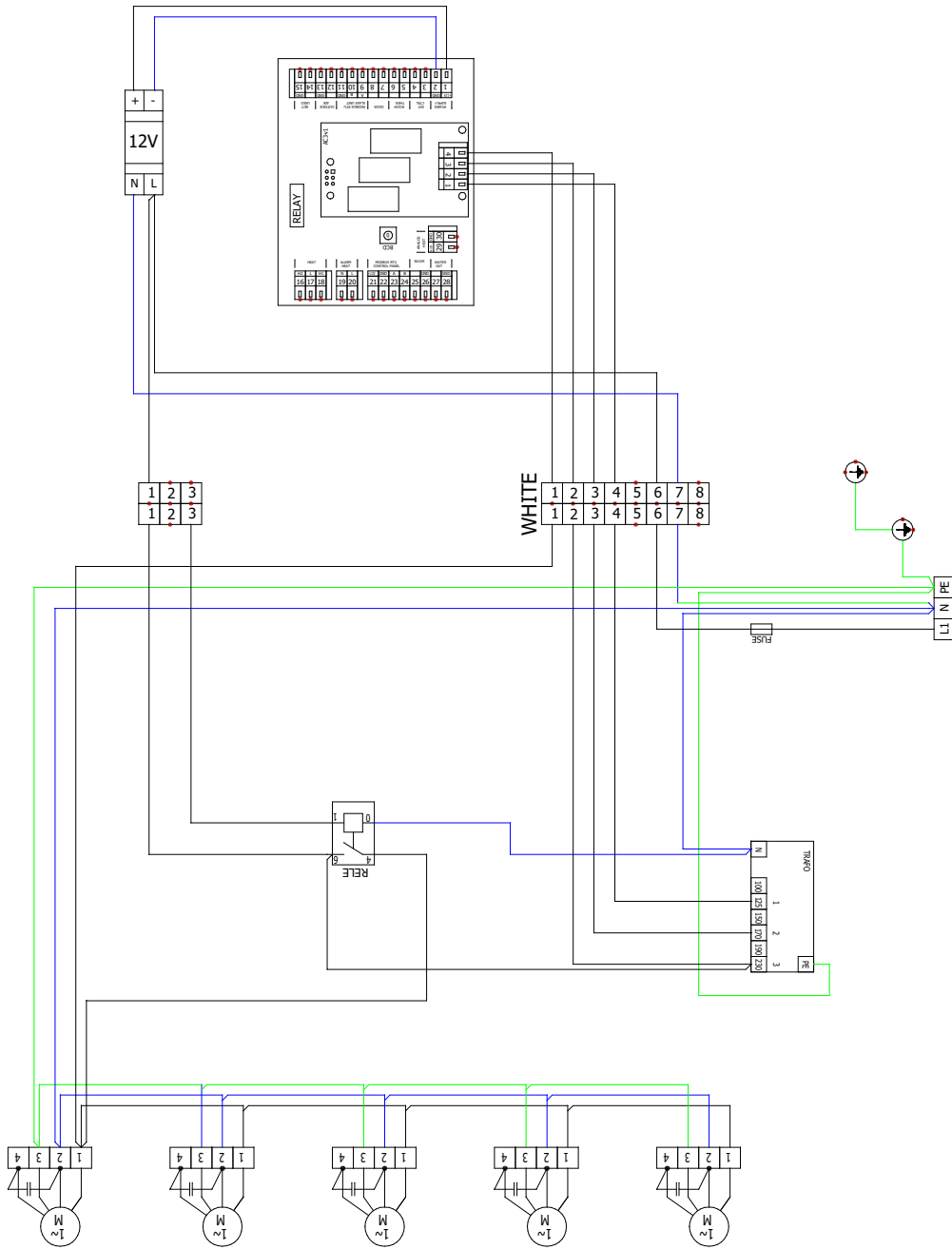

# 11. ELECTRICAL SCHEMES

## VCST5B-100/150/200-V2-AC-PR (with water heater)

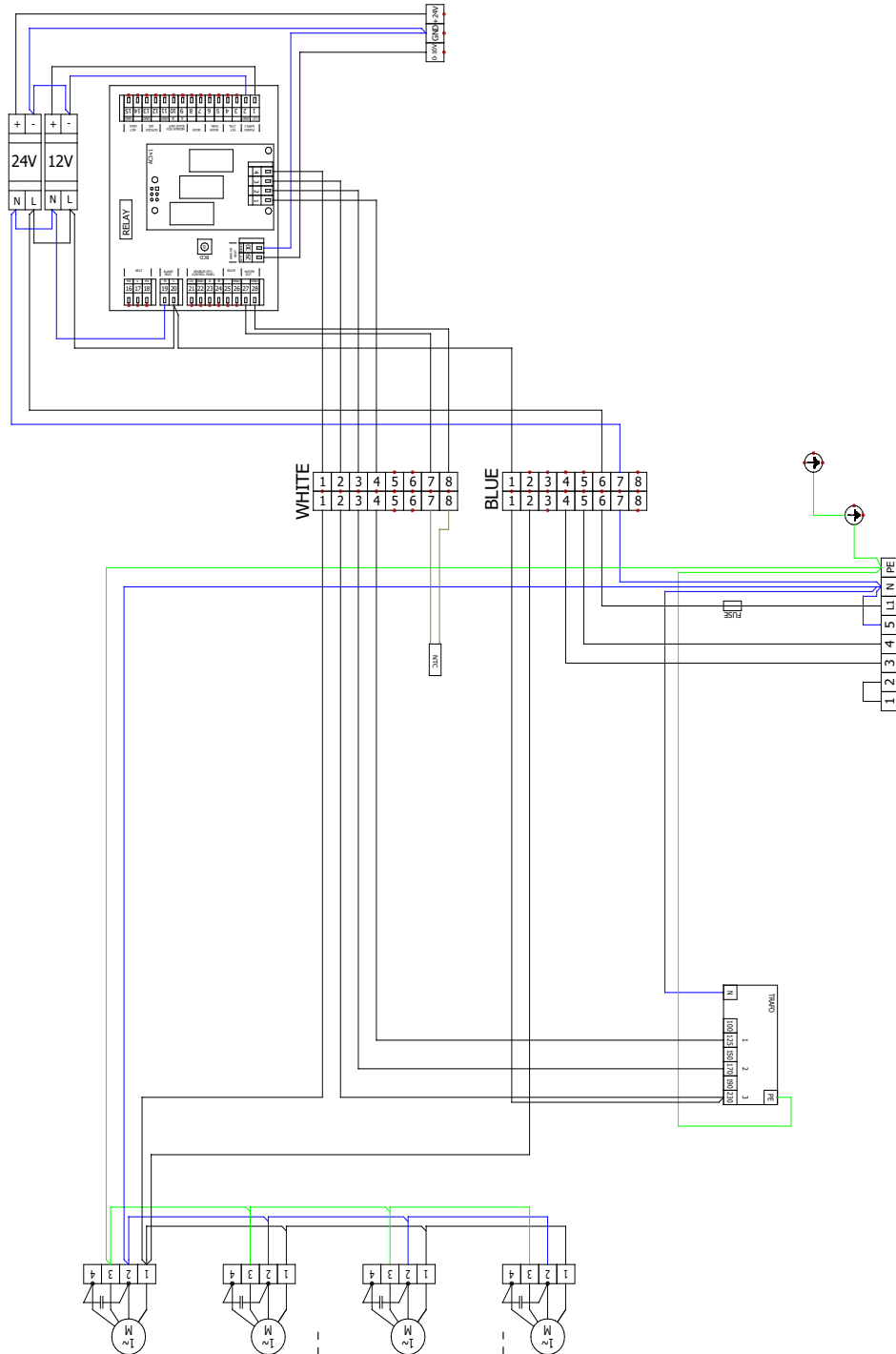

AC fans

VCST5 B-100 VCST5 B-150 VCST5 B-200

# 11. ELECTRICAL SCHEMES

## VCST5B-250-V2-AC-PR (with water heater)

AC fans

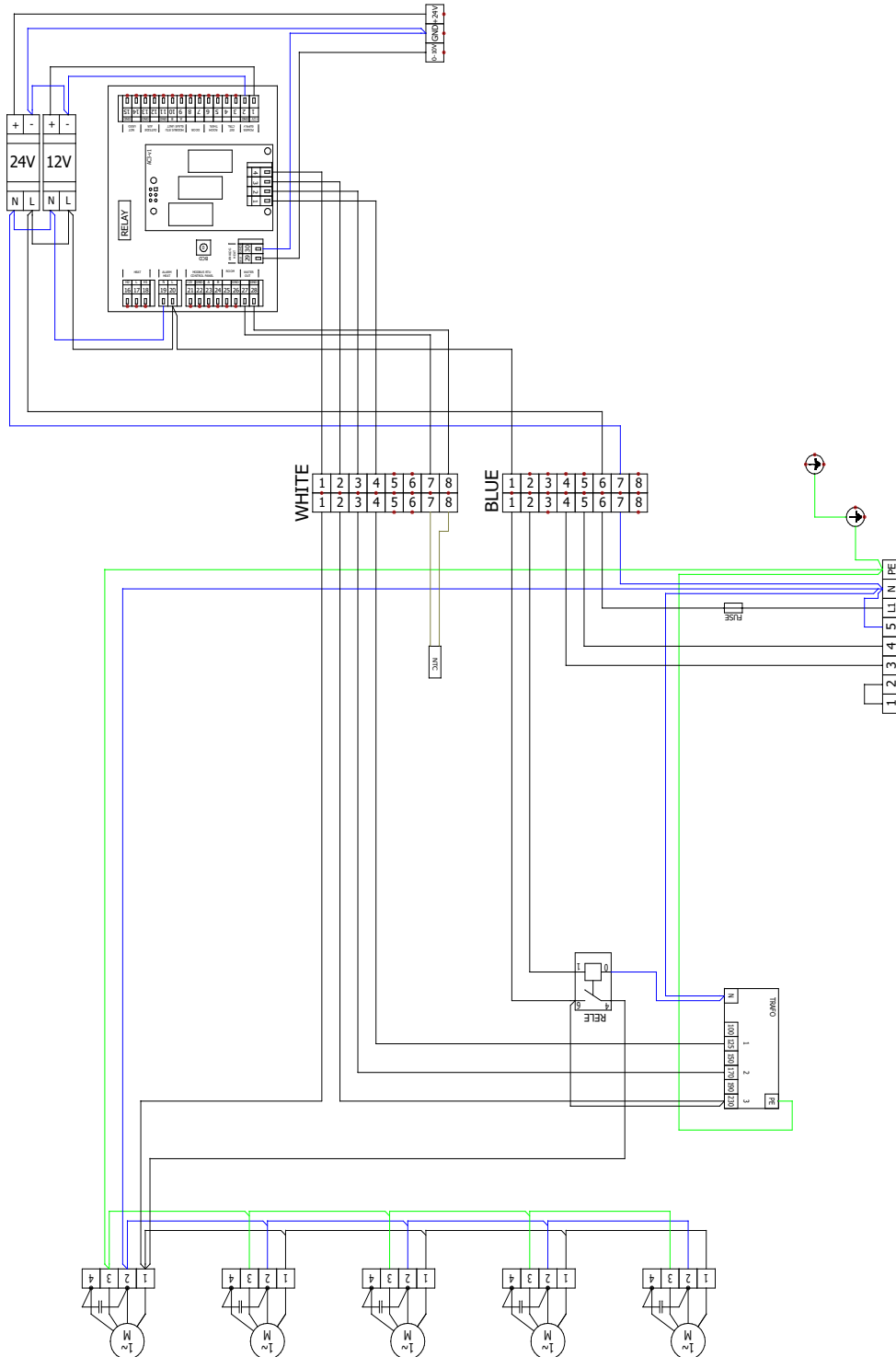

# 11. ELECTRICAL SCHEMES

## VCST5B-100-E1-AC-PR (with electric heater)

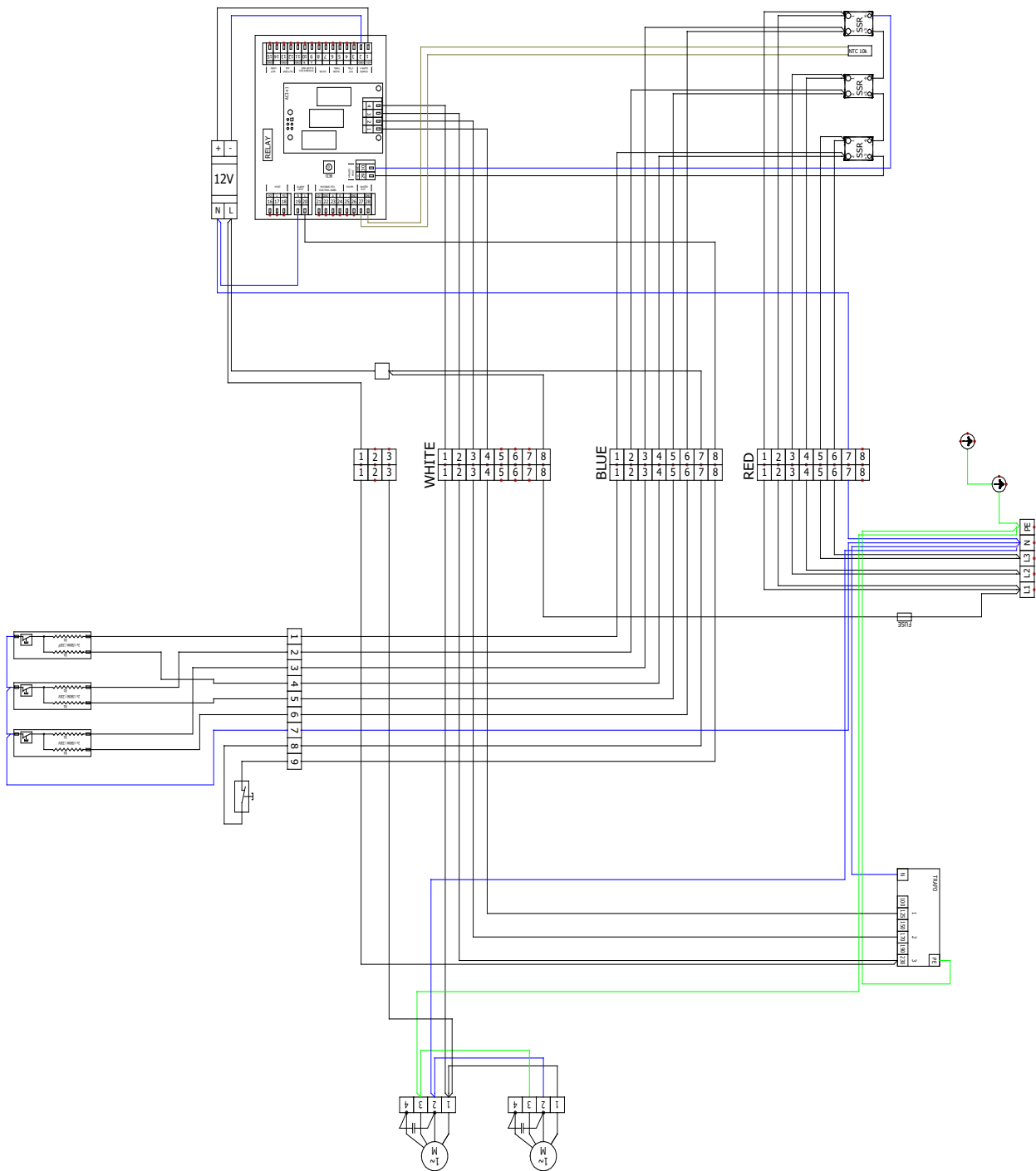

AC fans

# 11. ELECTRICAL SCHEMES

## VCST5B-150-E1-AC-PR (with electric heater)

AC fans

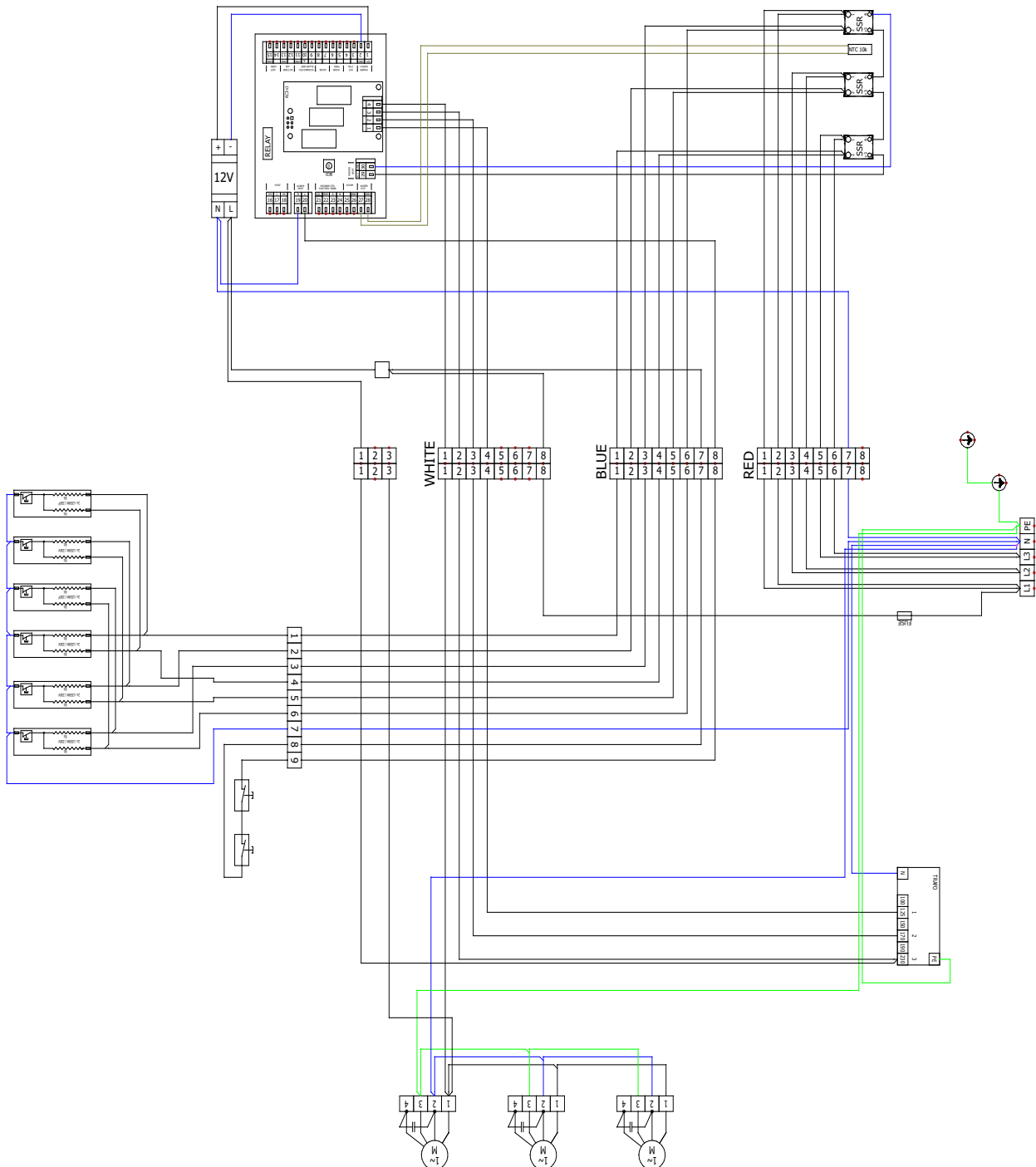

# 11. ELECTRICAL SCHEMES

## VCST5B-200-E1-AC-PR (with electric heater)

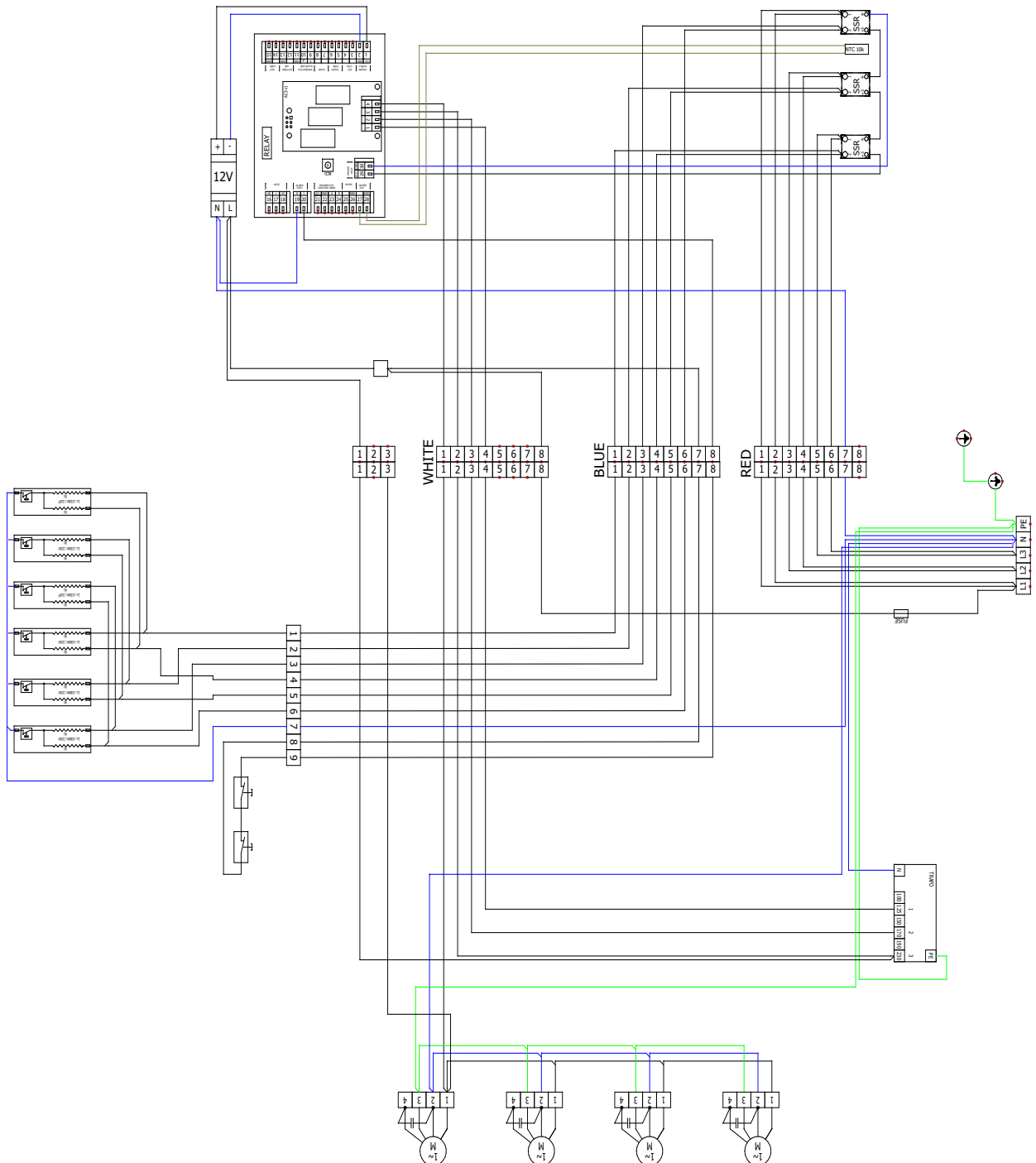

AC fans

# 11. ELECTRICAL SCHEMES

## VCST5B-250-E1-AC-PR (with electric heater)

AC fans

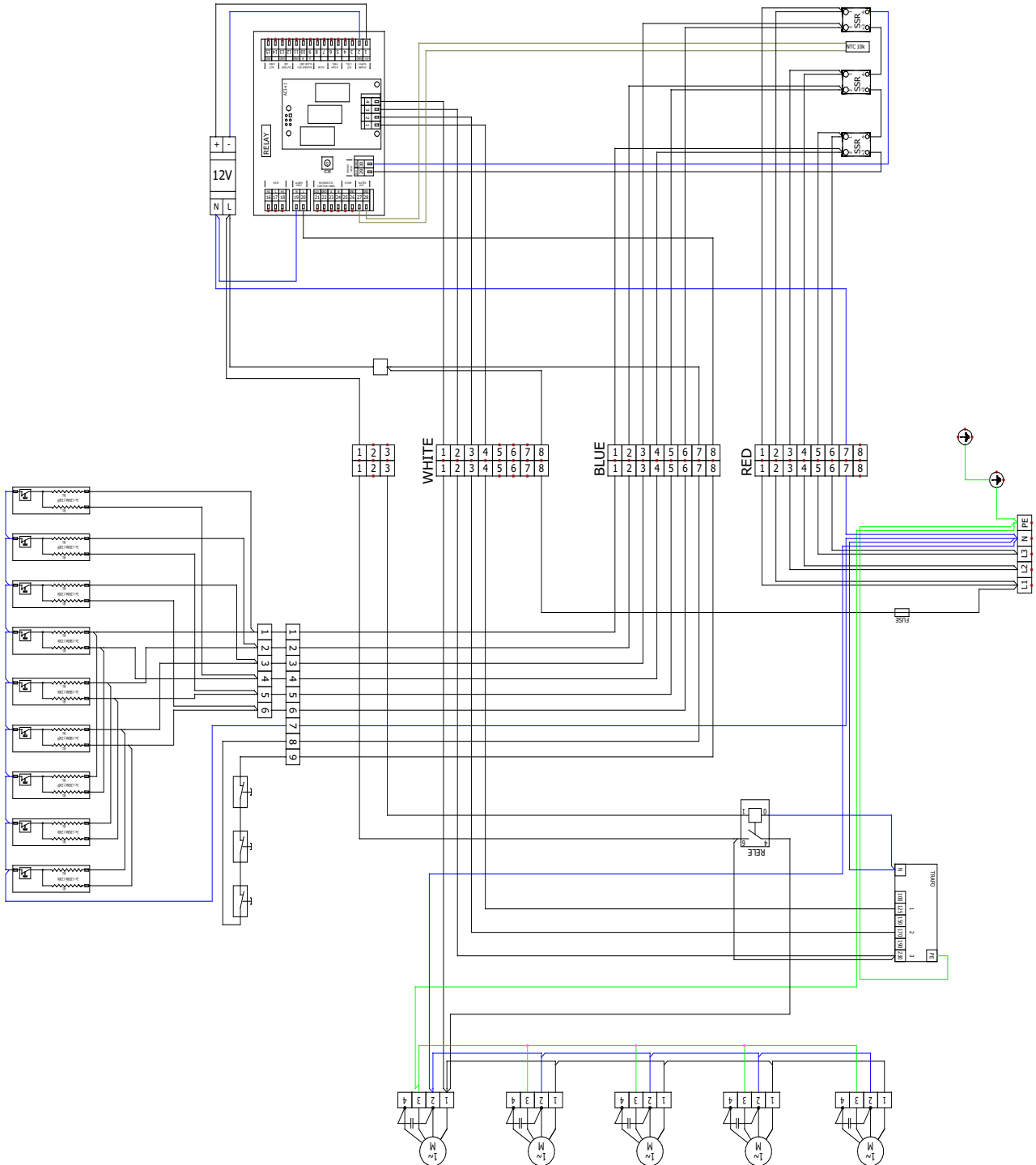

# 11. ELECTRICAL SCHEMES

## VCST5B-100/150/200-S0-EC-PR (without heater)

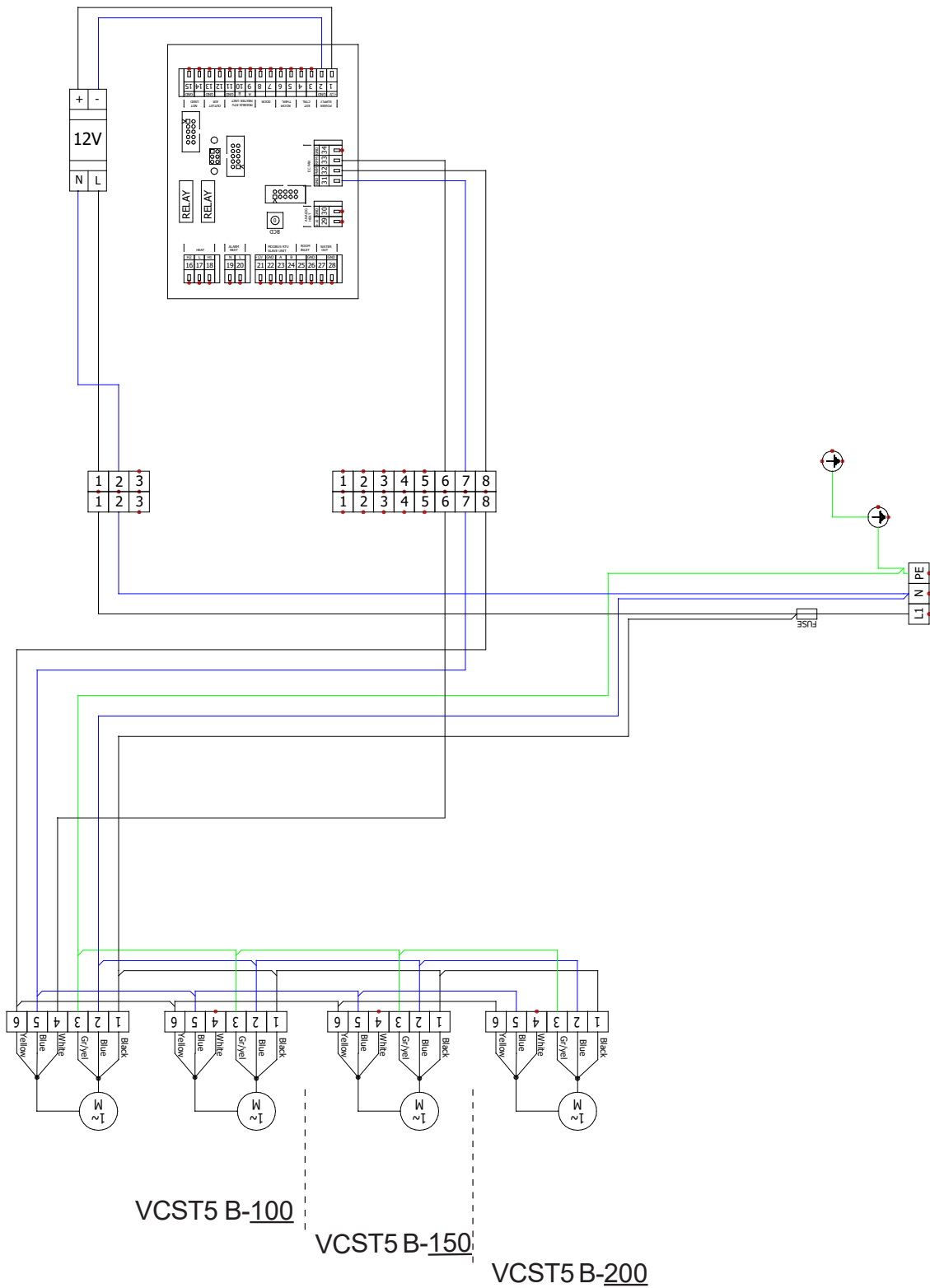

EC fans

# 11. ELECTRICAL SCHEMES

## VCST5B-250-S0-EC-PR (without heater)

EC fans

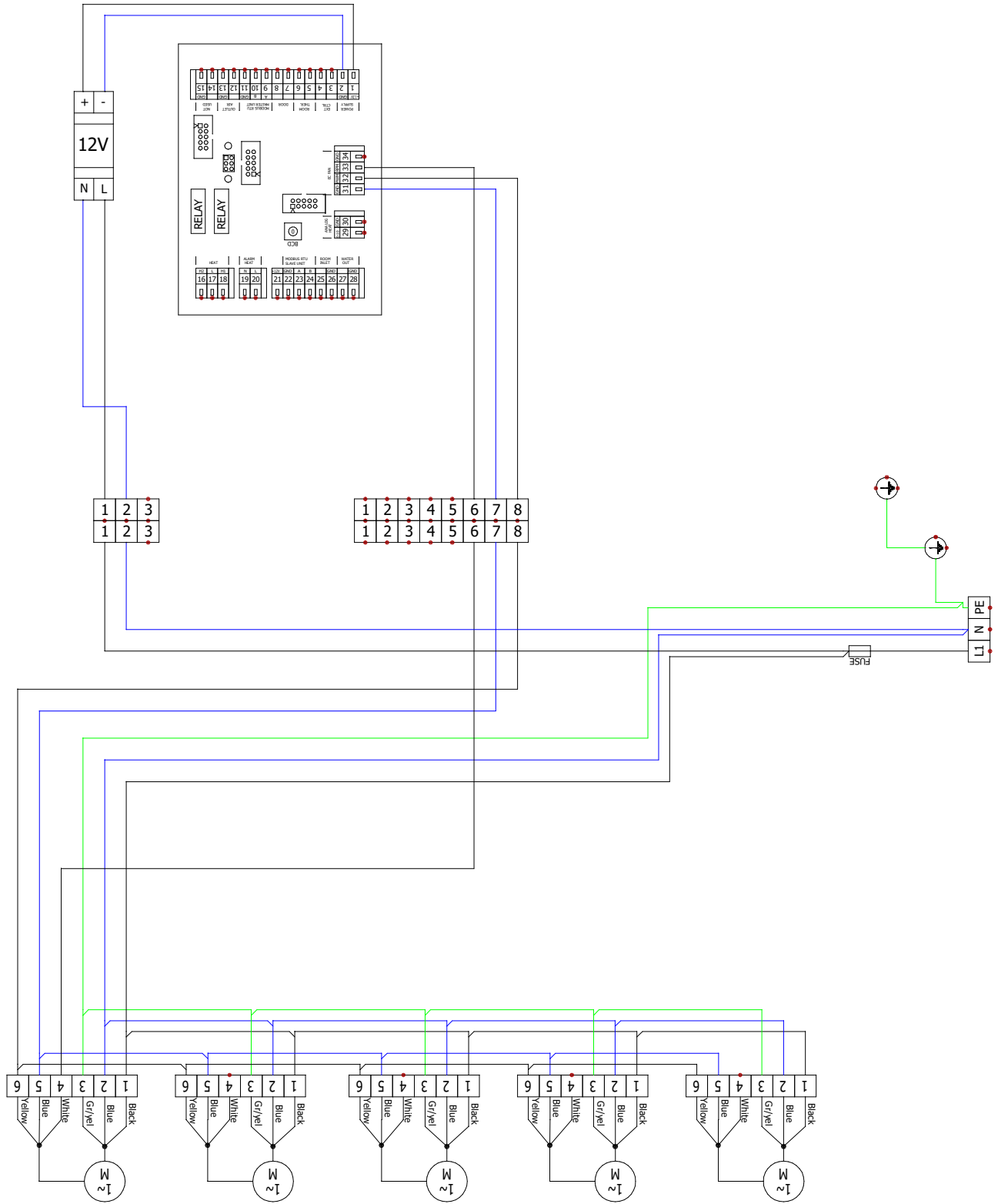

# 11. ELECTRICAL SCHEMES

## VCST5B-100/150/200-V2-EC-PR (with water heater)

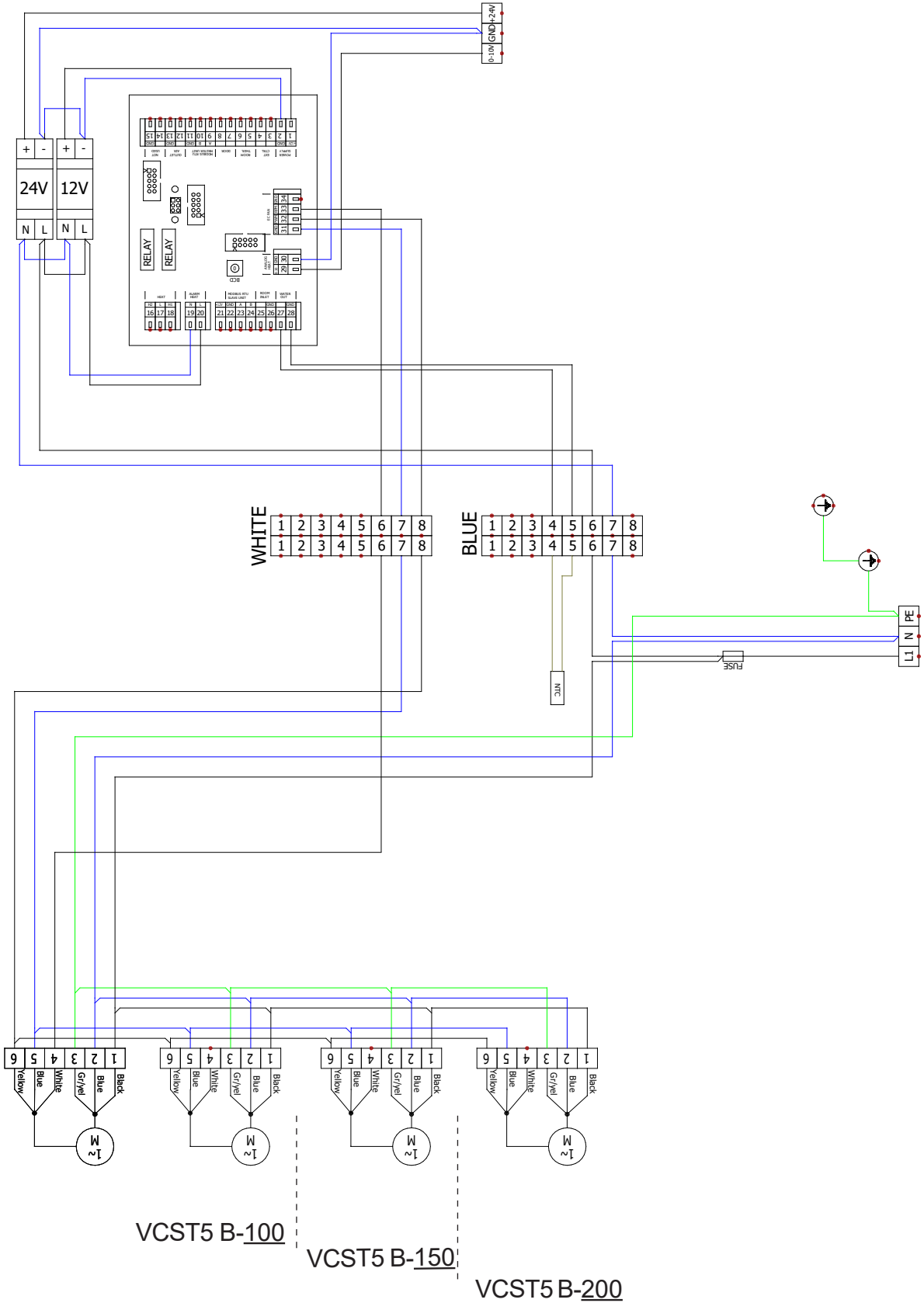

EC fans

# 11. ELECTRICAL SCHEMES

## VCST5B-250-V2-EC-PR (with water heater)

EC fans

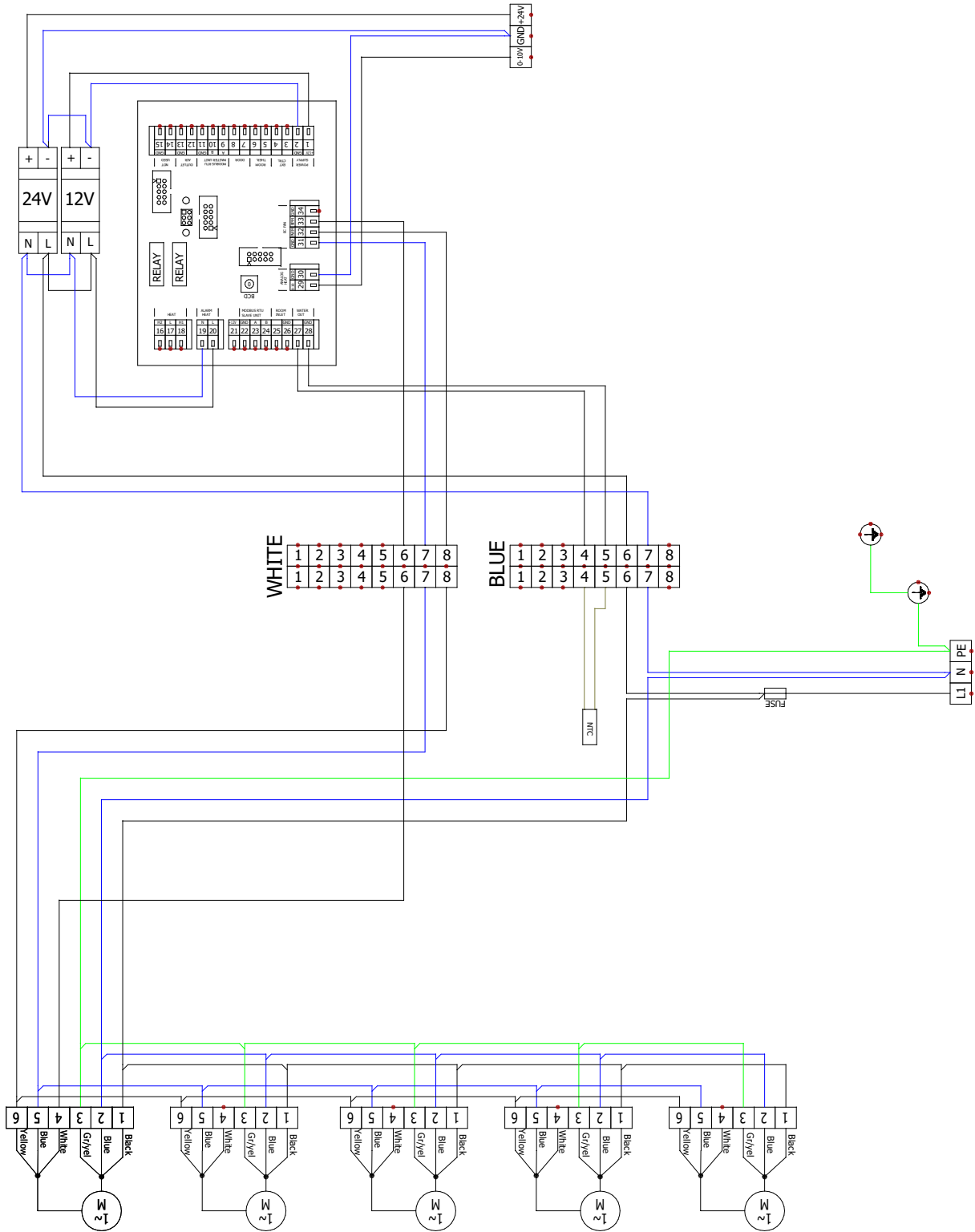

# 11. ELECTRICAL SCHEMES

## VCST5B-100-E1-EC-PR (with electric heater)

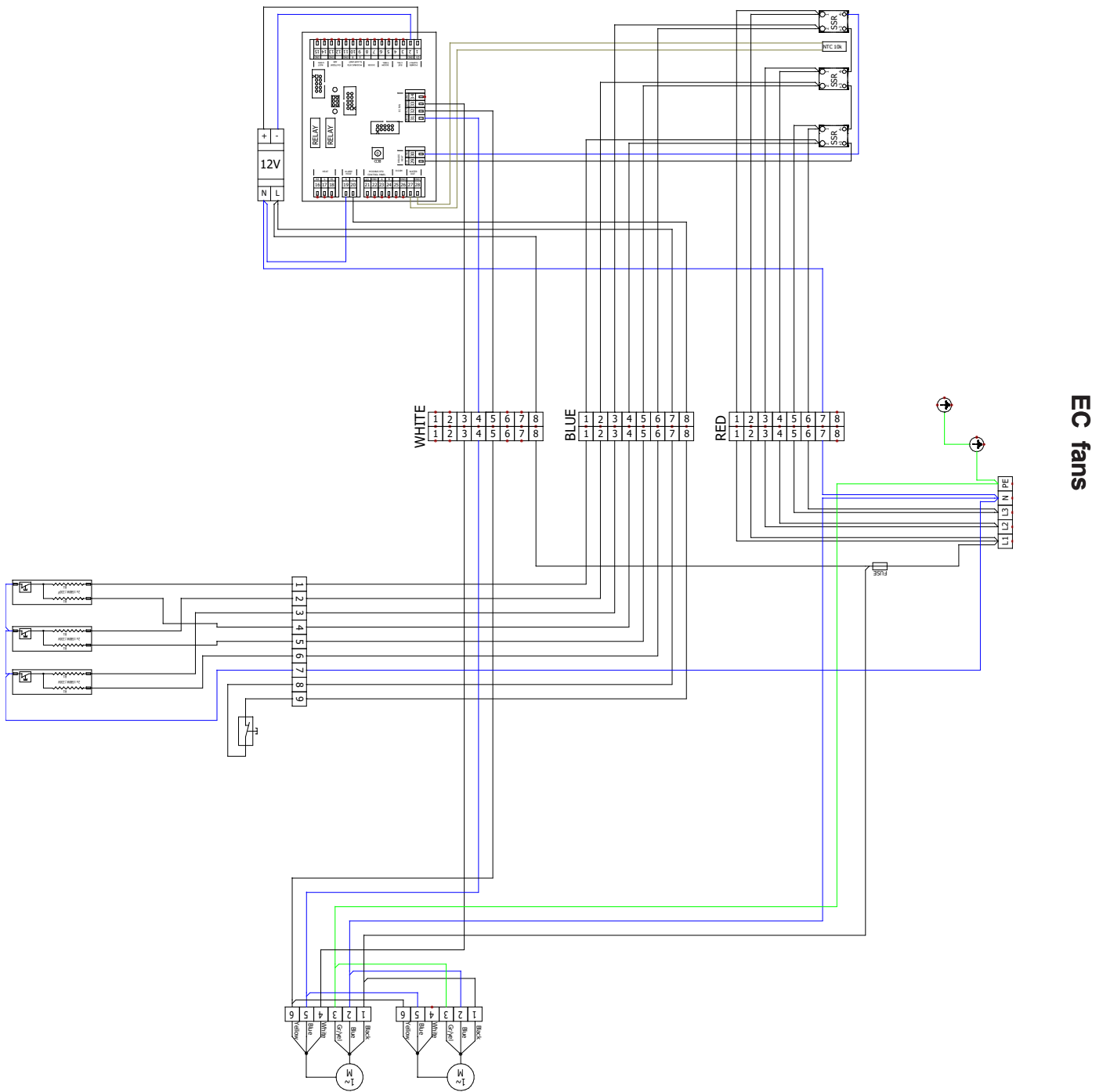

# 11. ELECTRICAL SCHEMES

## VCST5B-150-E1-EC-PR (with electric heater)

EC fans

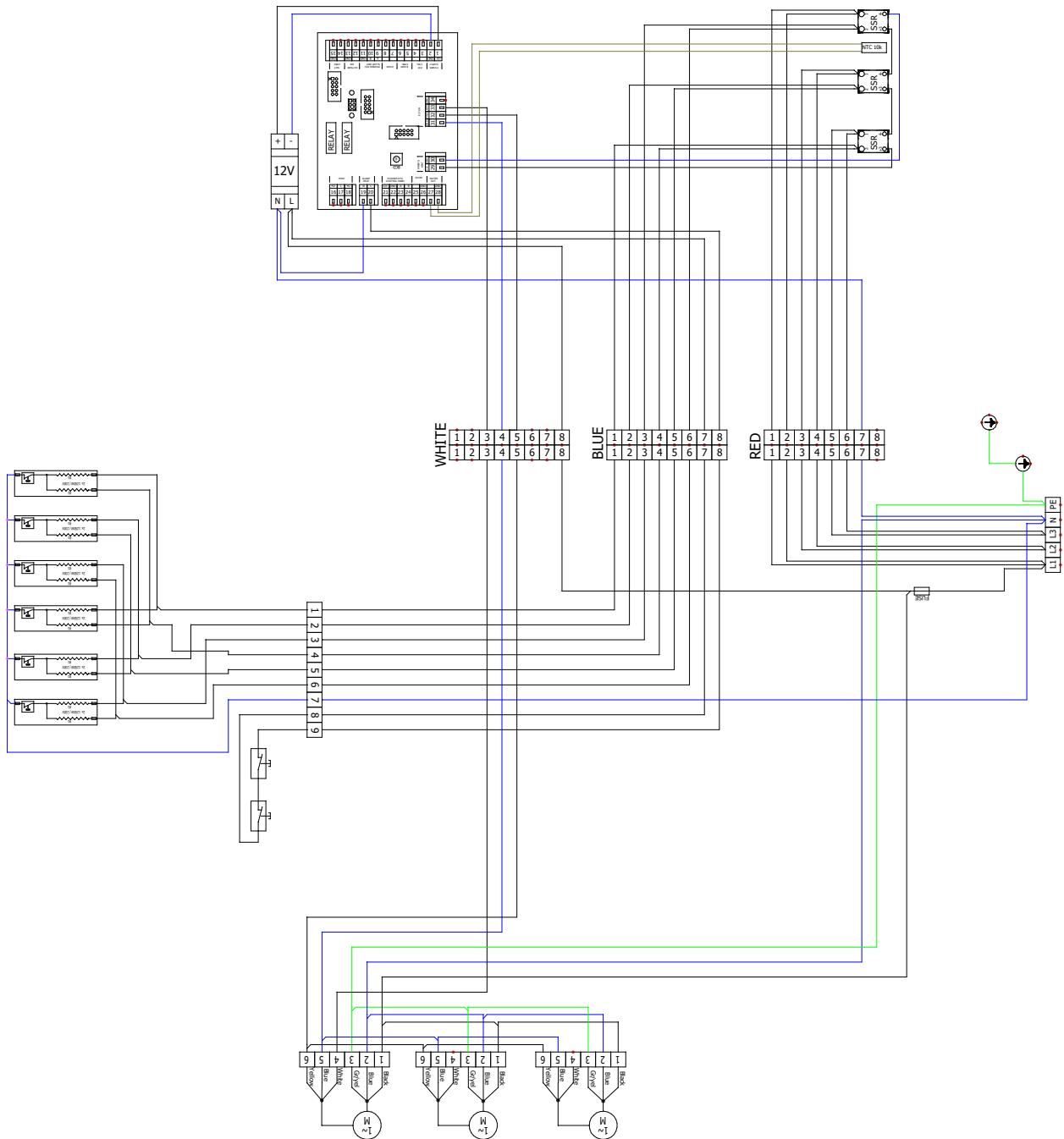

# 11. ELECTRICAL SCHEMES

## VCST5B-200-E1-EC-PR (with electric heater)

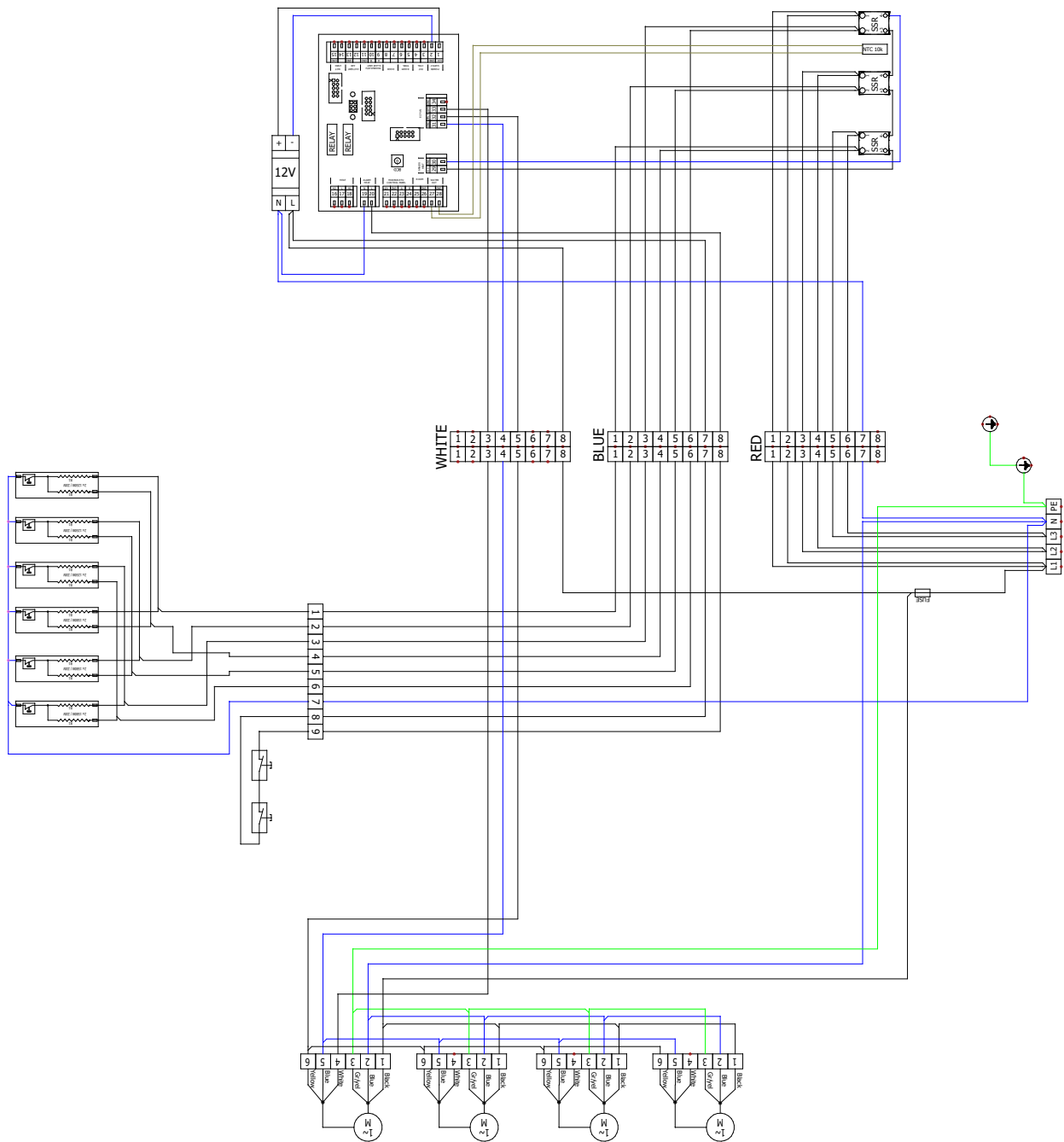

EC fans

# 11. ELECTRICAL SCHEMES

## VCST5B-250-E1-EC-PR (with electric heater)

EC fans

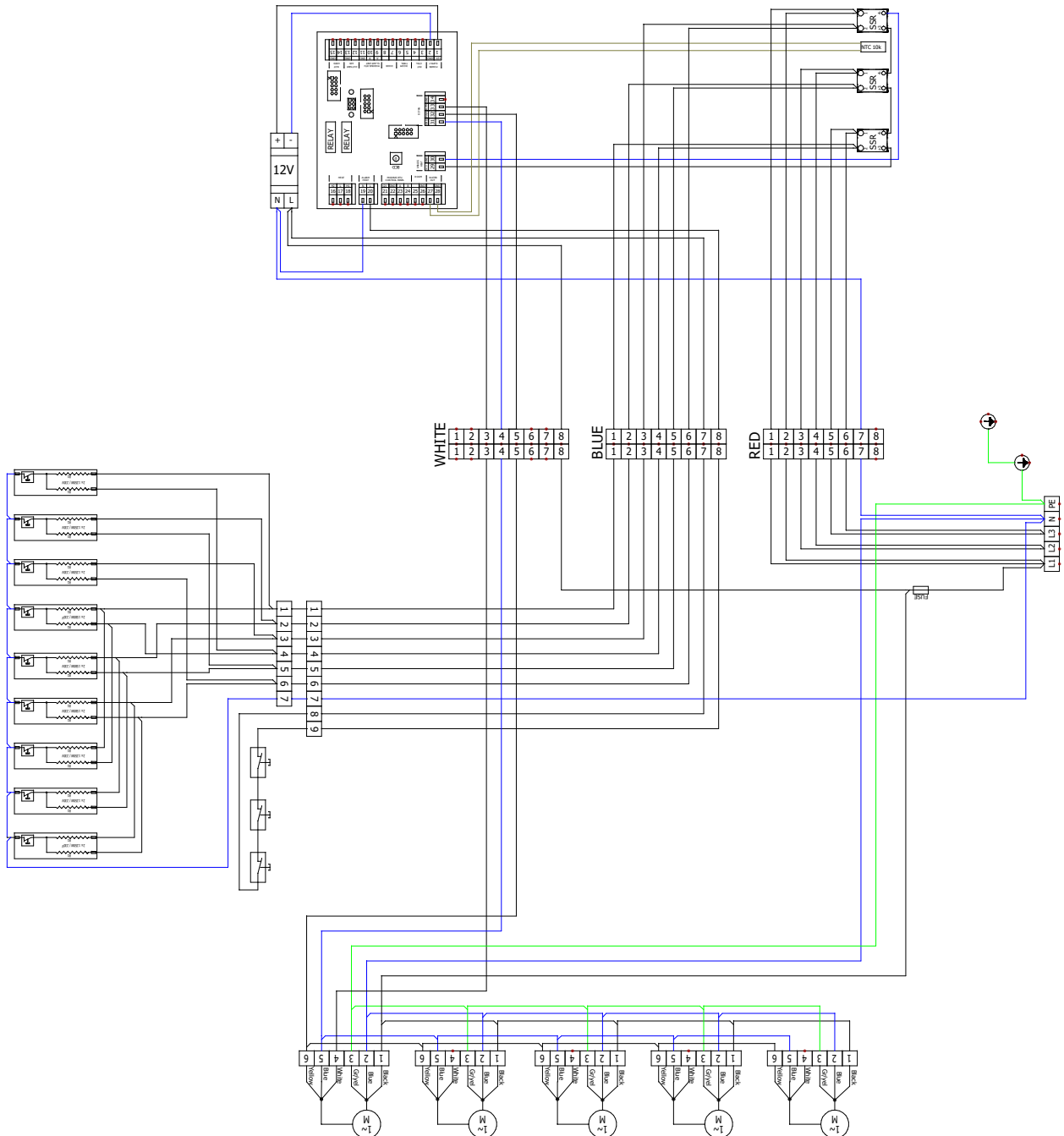

# 11. ELECTRICAL SCHEMES

## VCST5C-100/150/200-S0-EC-PR (without heater)

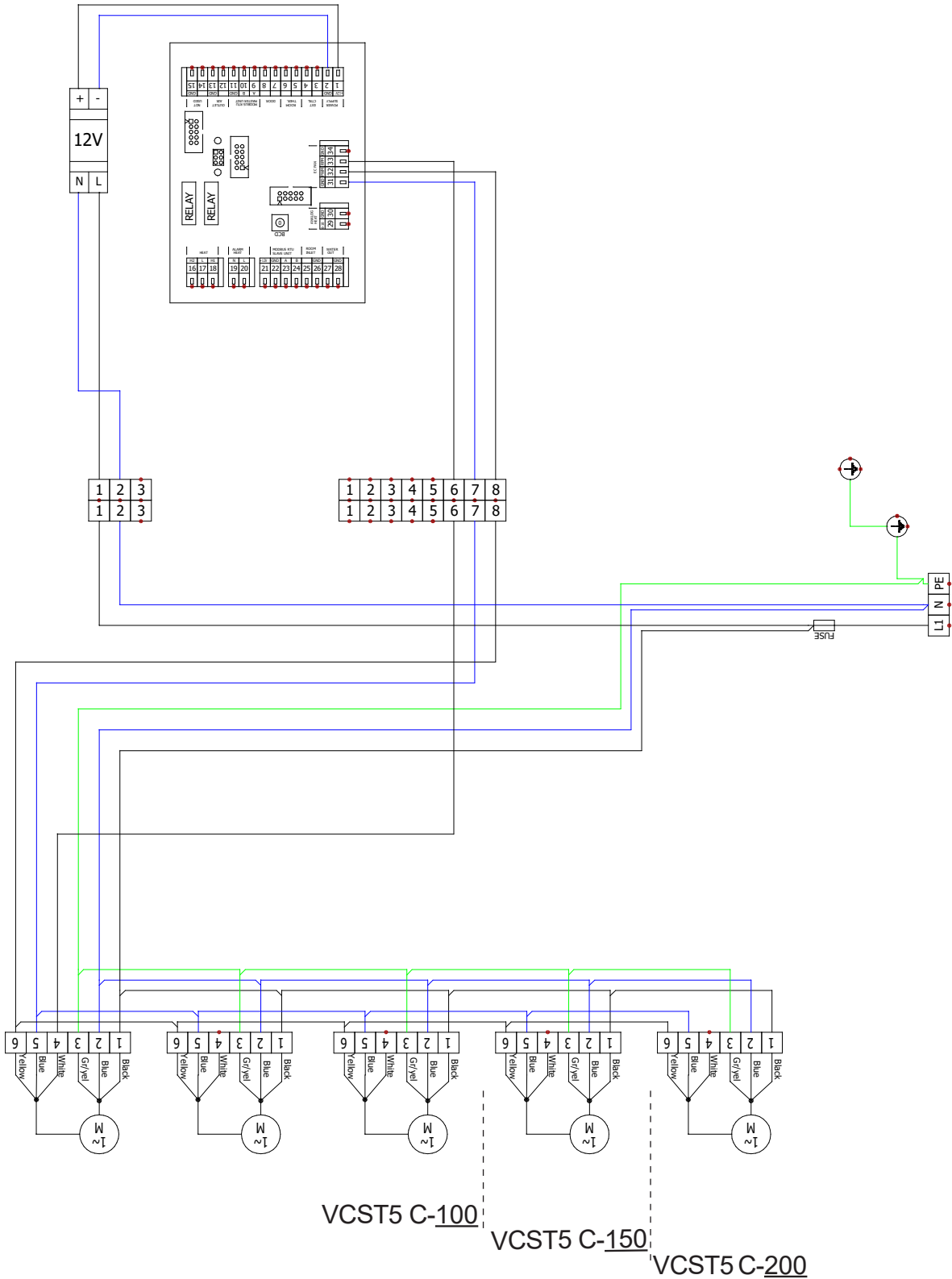

EC fans

# 11. ELECTRICAL SCHEMES

## VCST5C-250-S0-EC-PR (without heater)

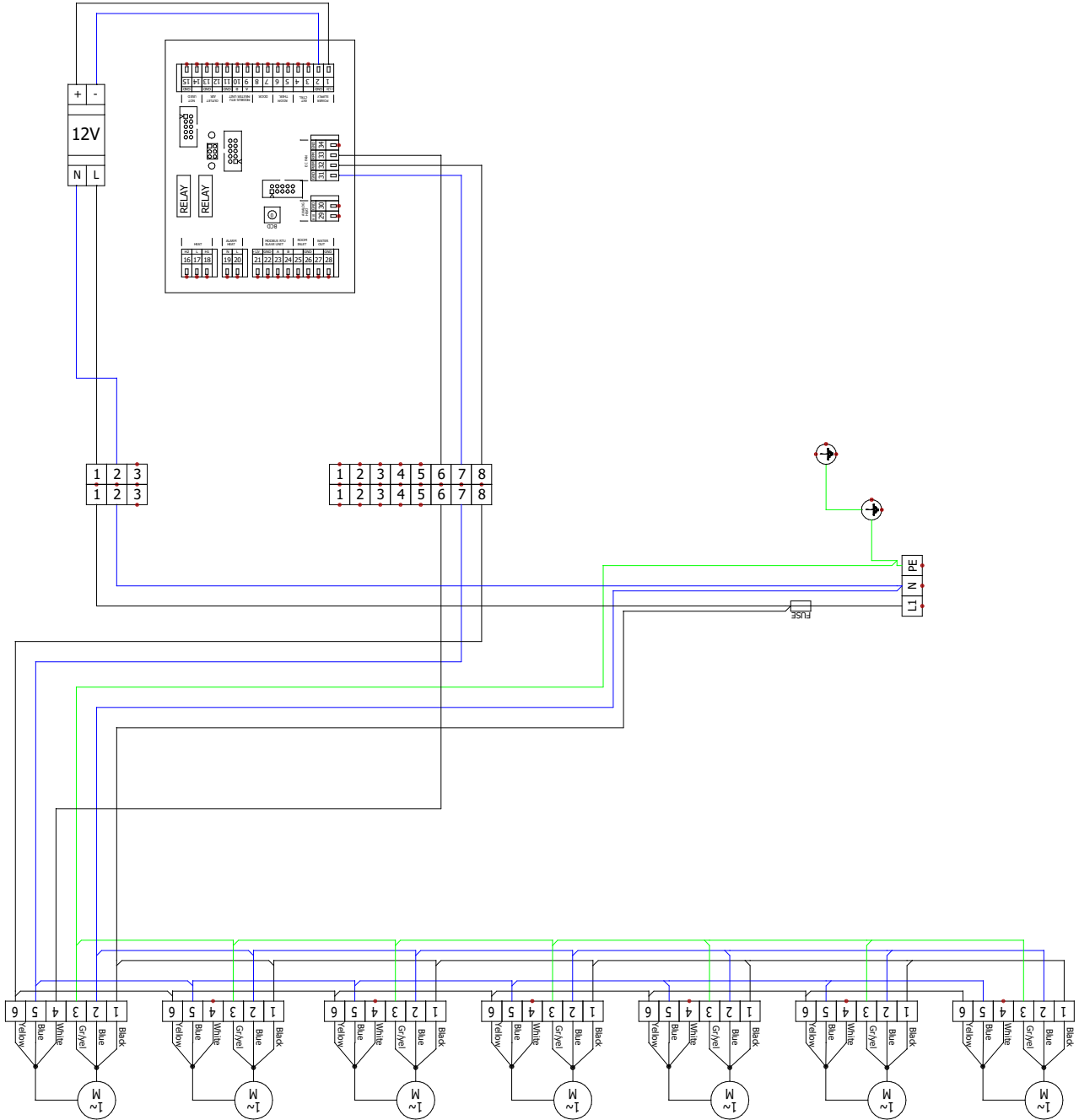

# 11. ELECTRICAL SCHEMES

## VCST5C-100/150/200-V2-EC-PR (with water heater)

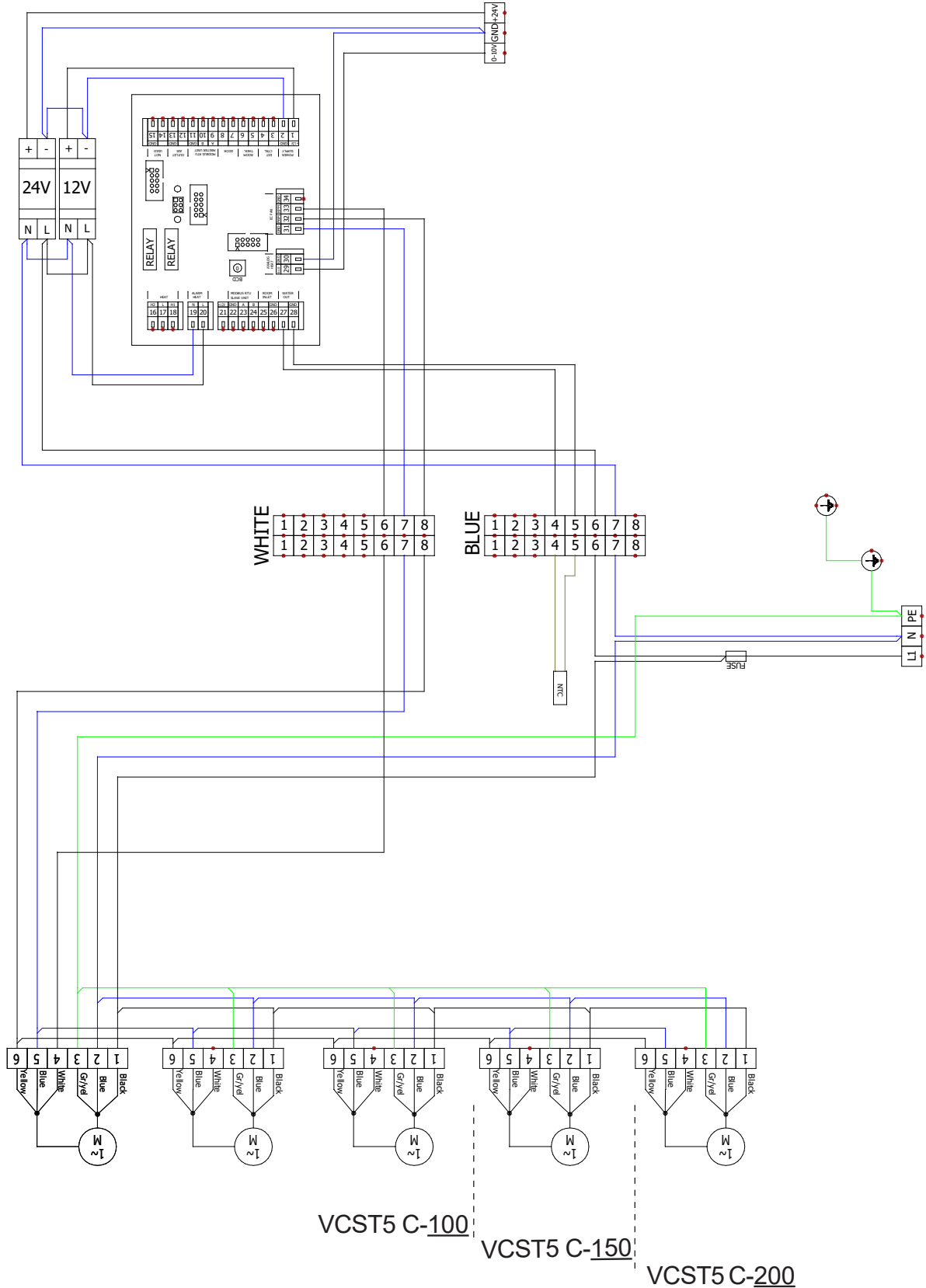

# 11. ELECTRICAL SCHEMES

## VCST5C-250-V2-EC-PR (with water heater)

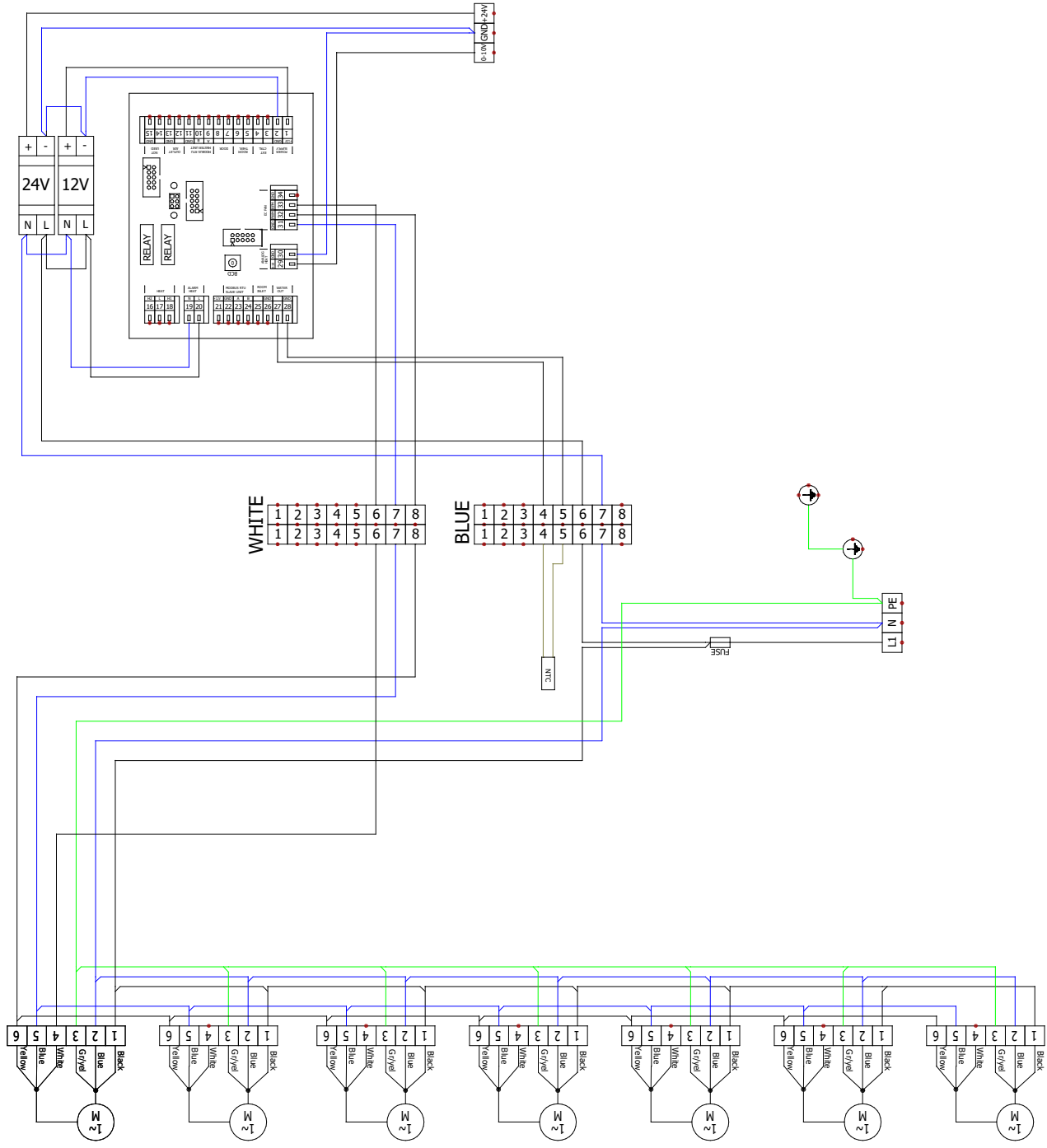

# 11. ELECTRICAL SCHEMES

## VCST5C-100-E1-EC-PR (with electric heater)

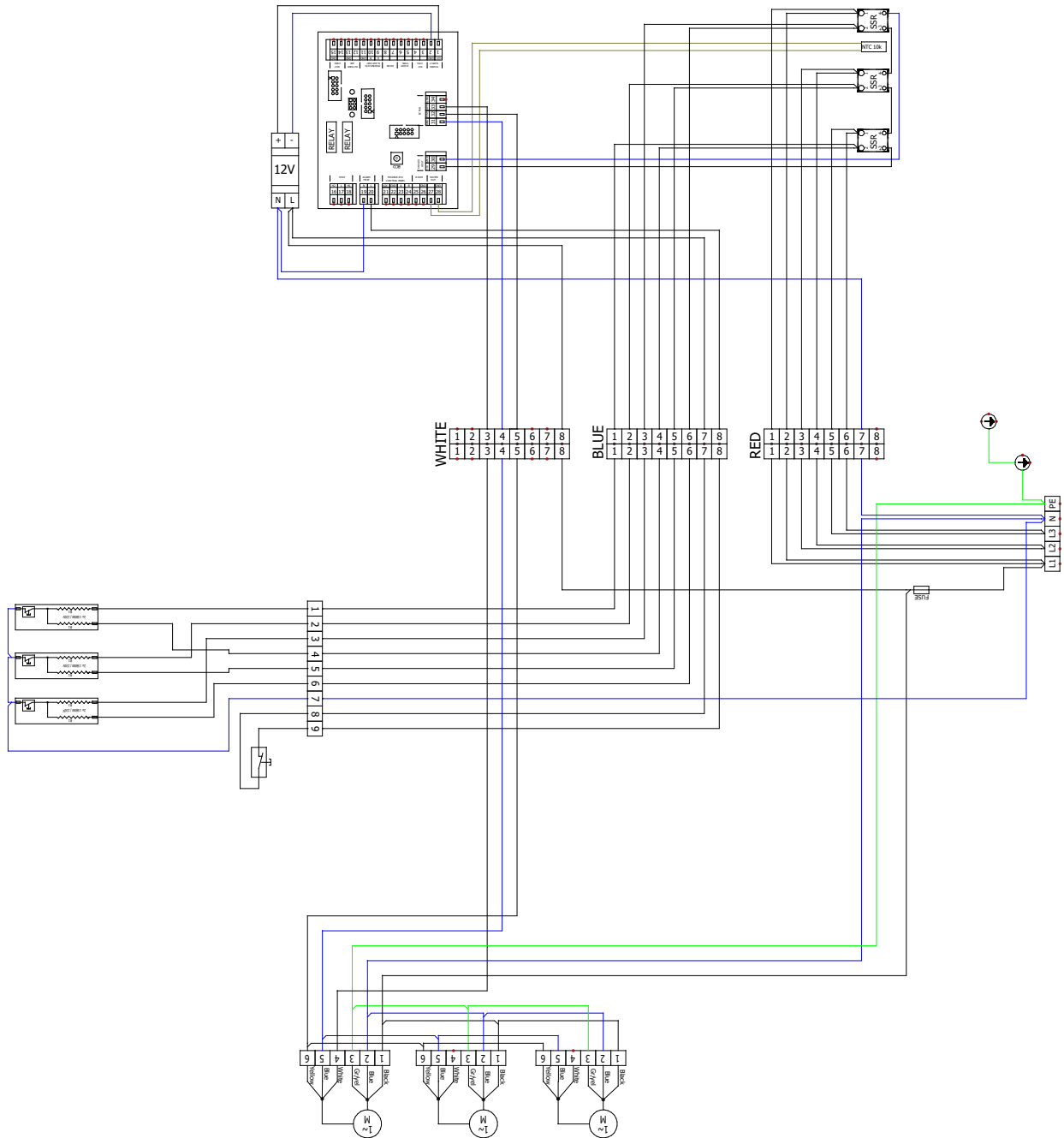

# 11. ELECTRICAL SCHEMES

## VCST5C-150-E1-EC-PR (with electric heater)

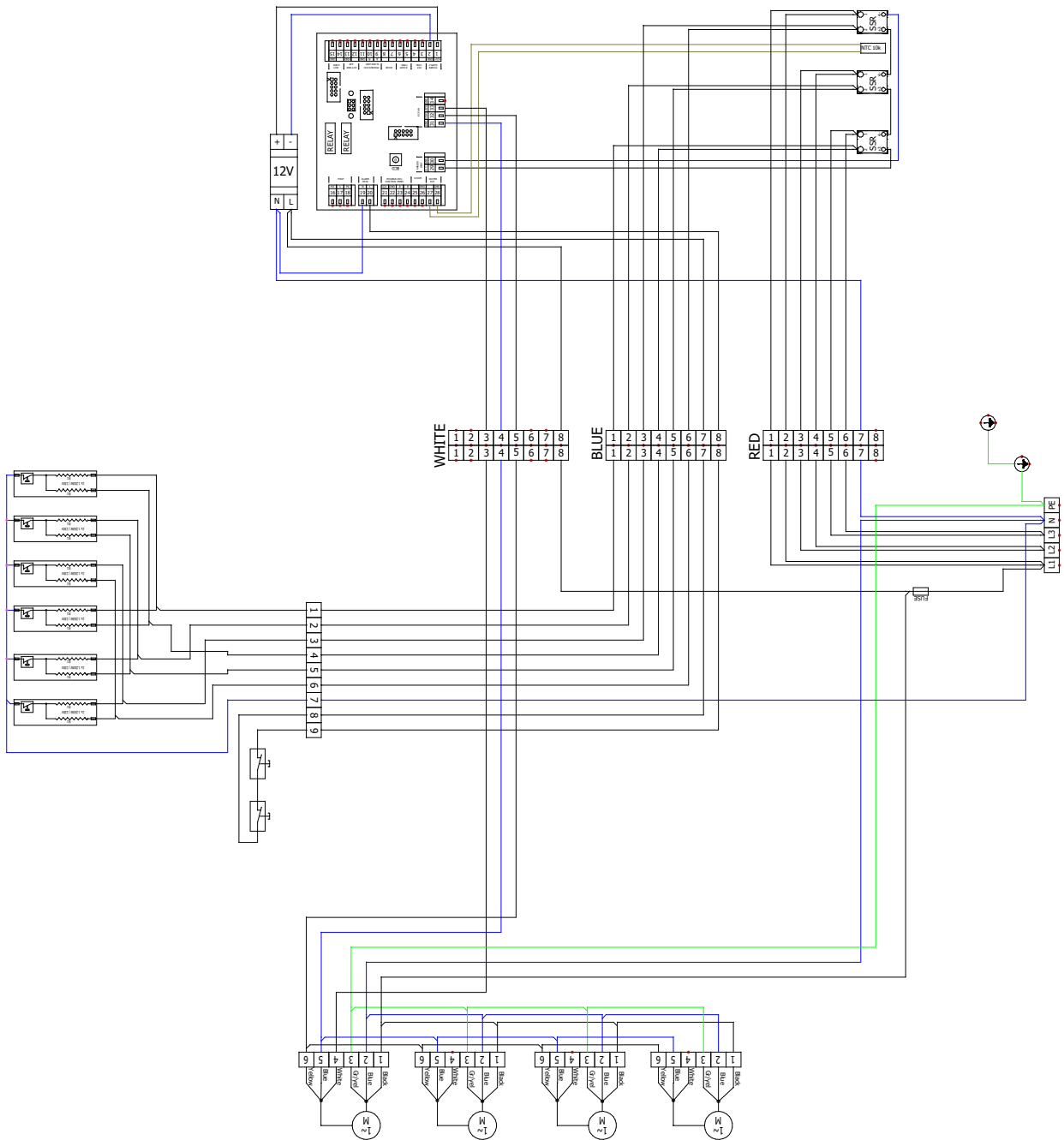

# 11. ELECTRICAL SCHEMES

## VCST5C-200-E1-EC-PR (with electric heater)

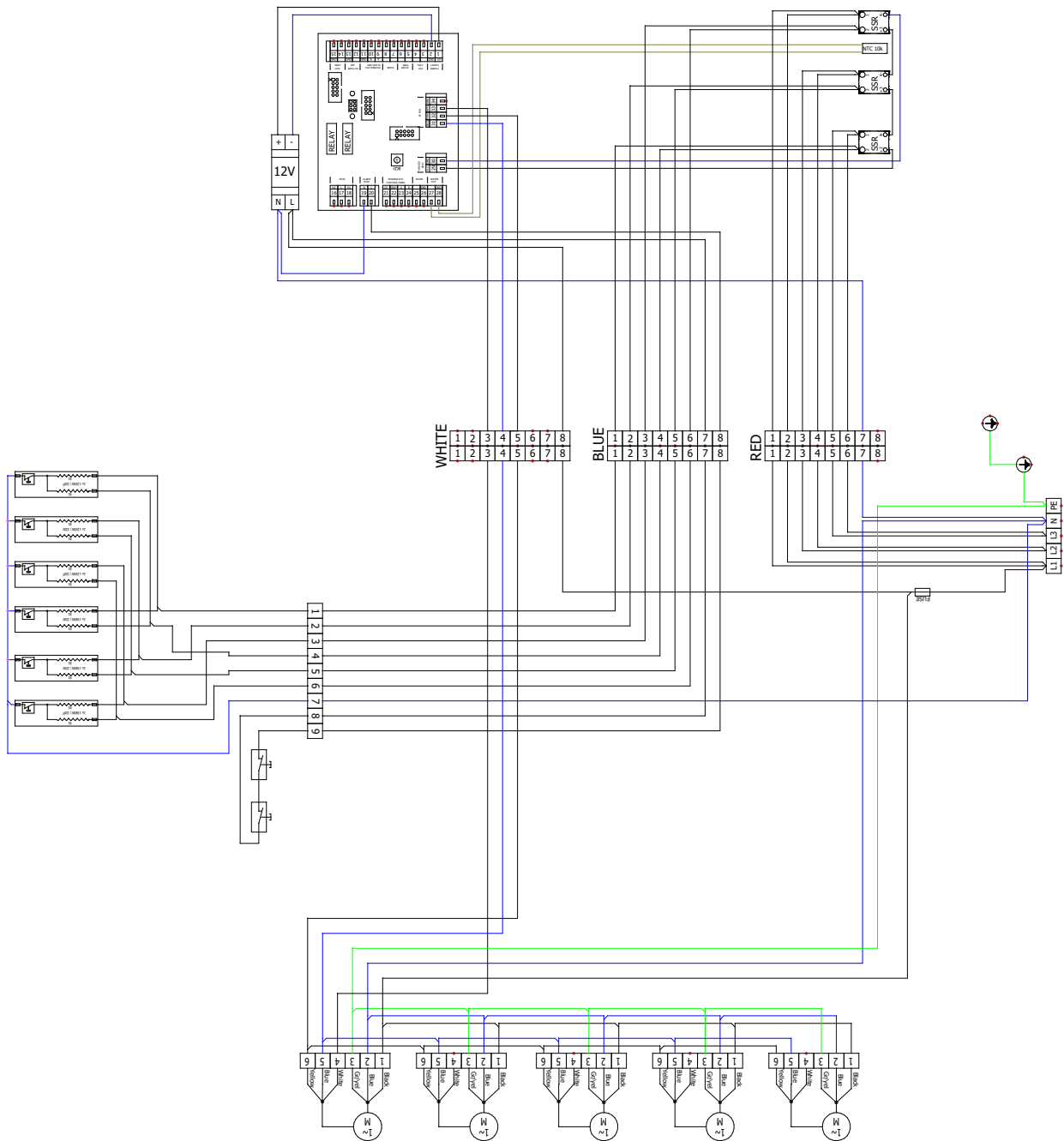

# 11. ELECTRICAL SCHEMES

## VCST5C-250-E1-EC-PR (with electric heater)

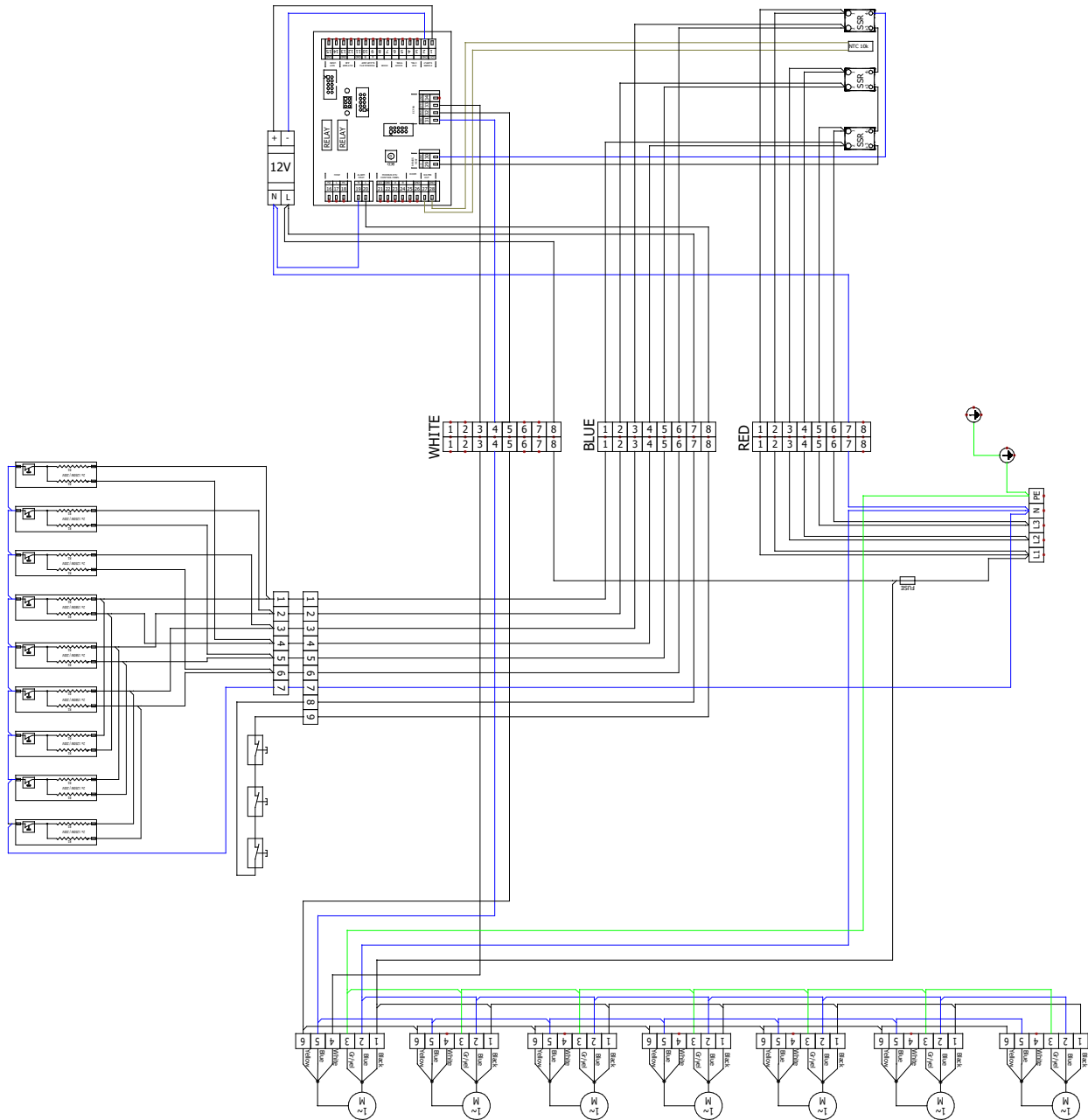

## 12. CONCLUSION

After installing the air curtain, read carefully the **Manual for the appropriate regulator**. In case of any doubt or query, do not hesitate to contact our sales or technical support departments.

## **CONTACT**

**Address:**

2VV s.r.o.  
Nádražní 794  
533 51 Pardubice - Rosice  
Czech Republic

**Internet:**

<http://www.2vv.cz/>

