



PARTNER
IN VENTILATION
2VV.CZ

EN

VENUS

READY version

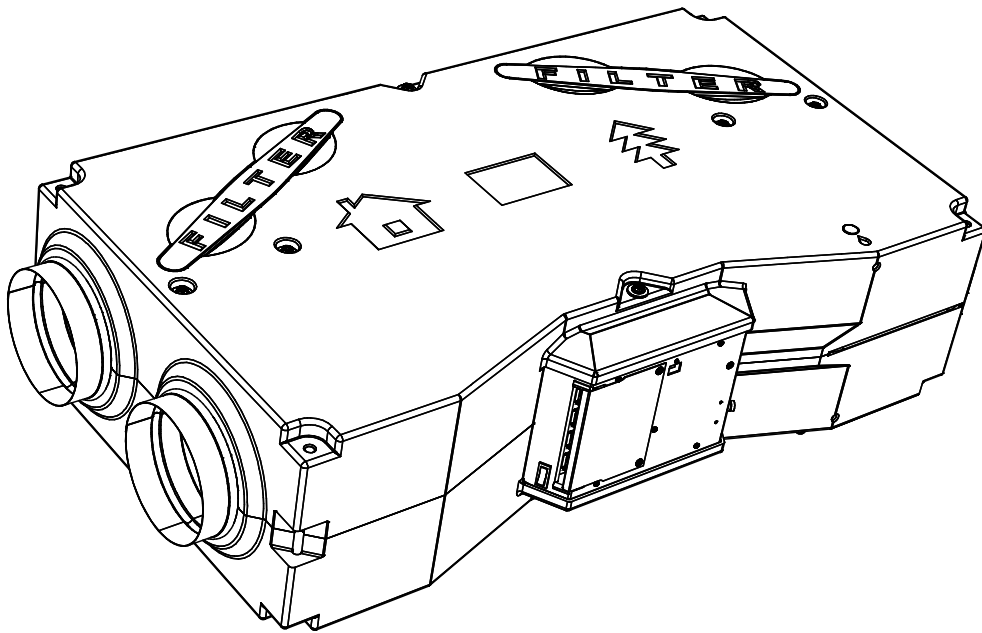

P02-0313-0813-20









4-118-0191

CE EAC

1. BEFORE YOU BEGIN

For better orientation, the following symbols can be found in the text of the instruction manual. The following table describes the symbols and their meaning.

Symbol	Meaning
	Warning or notice
 ATTENTION!	
 DO NOT MISS!	Important instructions
 YOU WILL NEED	Practical tips and information
 TECHNICAL INFORMATION	Further detailed technical information
	Reference to another section /part of the instruction manual



Please read carefully the section **on the safety operation of the ventilation unit** prior to installation, where you can find all the instructions for the safe and correct use of the product.

This instruction manual contains important instructions for the provision of the correct installation of the ventilation unit. Please read all the following instructions prior to installation of the ventilation unit! The manufacturer reserves the right for amendments including technical documentation prior to previous notification. Keep the manual safe for future reference. Consider the manual instructions as part of the product.

Declaration of conformity

The declaration of conformity can be found on our website www.2vv.cz.

2. FITTINGS

2.1 CHECK THE SUPPLIED UNIT

DO NOT MISS!

- Check immediately on delivery, that the packaged product is not damaged. In the event of damaged packaging, consult the haulier.
- In the event that any reclaim will not be applied in time, future applications will not be processed.
- Check if the product type is the one you have ordered. In the event that it is not the ordered unit, do not open the packaging and report the fault to the supplier immediately.
- After unpacking the product, check that the units and accessories are in order. If you have any doubts, contact the supplier.
- Never try to operate a damaged ventilation unit.
- In the event that you decide not to unpack the ventilation unit immediately after delivery, the product must be stored in a dry interior with a temperature ranging from **+5 °C up to +35 °C** maximum.
- This product is not intended for use by persons (including children) whose physical, sensory or mental incapacity or lack of experience and knowledge in the safe use of products when they are not supervised or, if they were not instructed on the use of the product by a person responsible for their safety.
- Children should be supervised to ensure that they do not play with the unit.

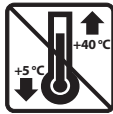

	All packaging materials used are ecological and they can therefore be used repeatedly or recycled. Please contribute actively to the protection of the environment and ensure the regular liquidation and recycling of the packaging materials.	
--	---	--

2.2 UNPACKING THE UNIT

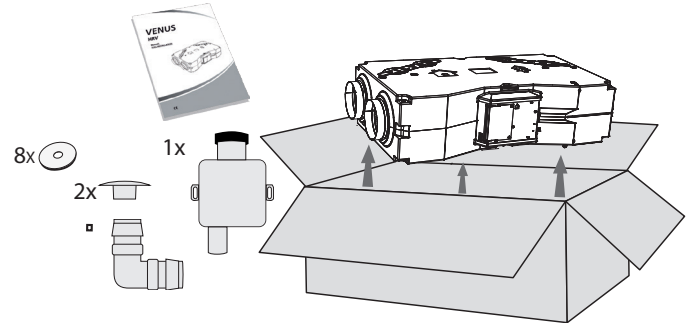

DO NOT MISS!

- In the event that the ventilation unit was transported in a temperature lower than 0 °C, it is necessary to leave the unit for at least 2 hours without turning it on, allowing the temperature inside the unit to be levelled to the temperature of the surrounding area.

3. MAIN COMPONENTS

- 1 Suction neck
- 2 Exhaust neck
- 3 Heat exchanger
- 4 Fans
- 5 Regulation box
- 6 Condensate exhaust
- 7 Filters

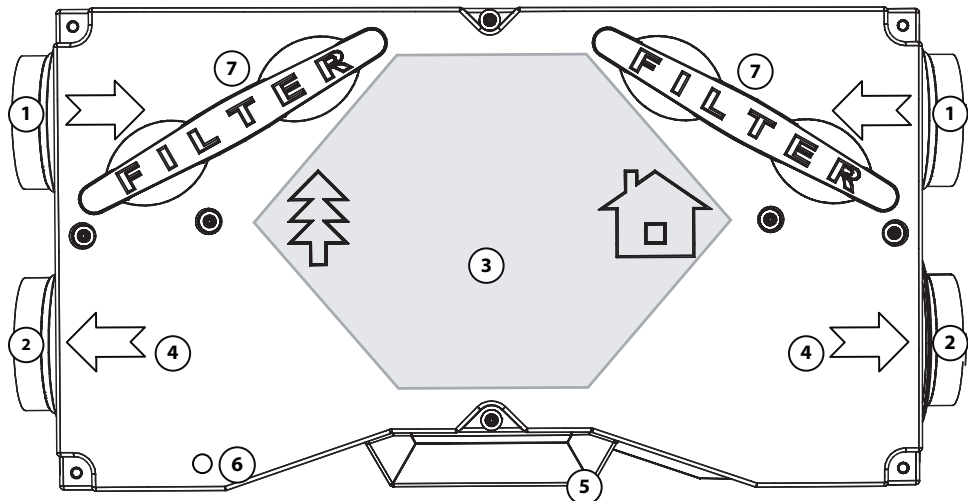

4. DIMENSIONS

HRV15 and HRV30:

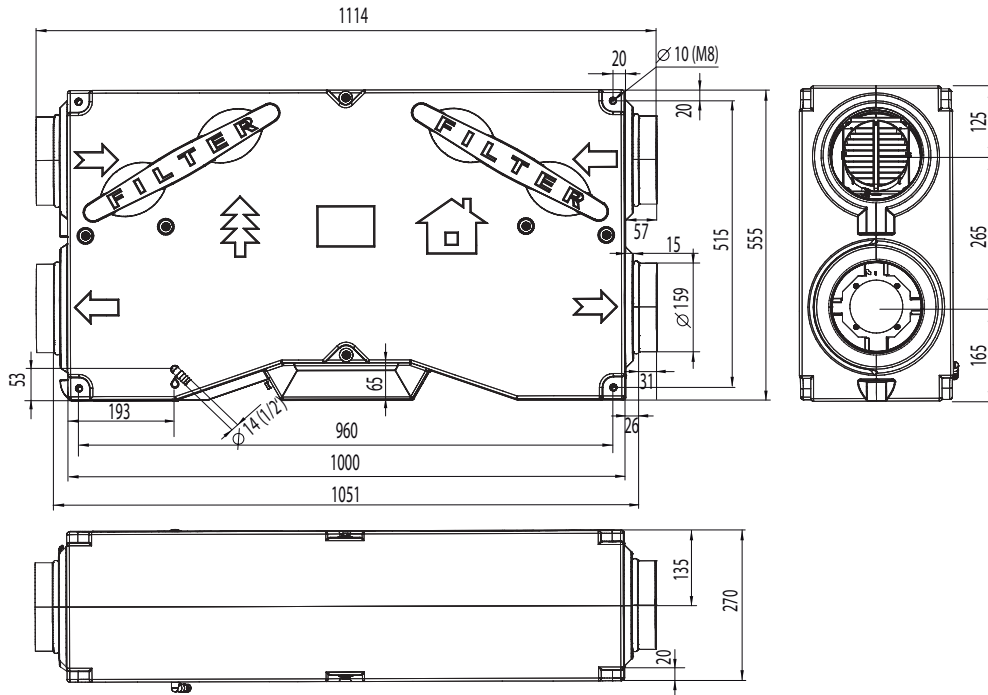

HRV50 and HRV70

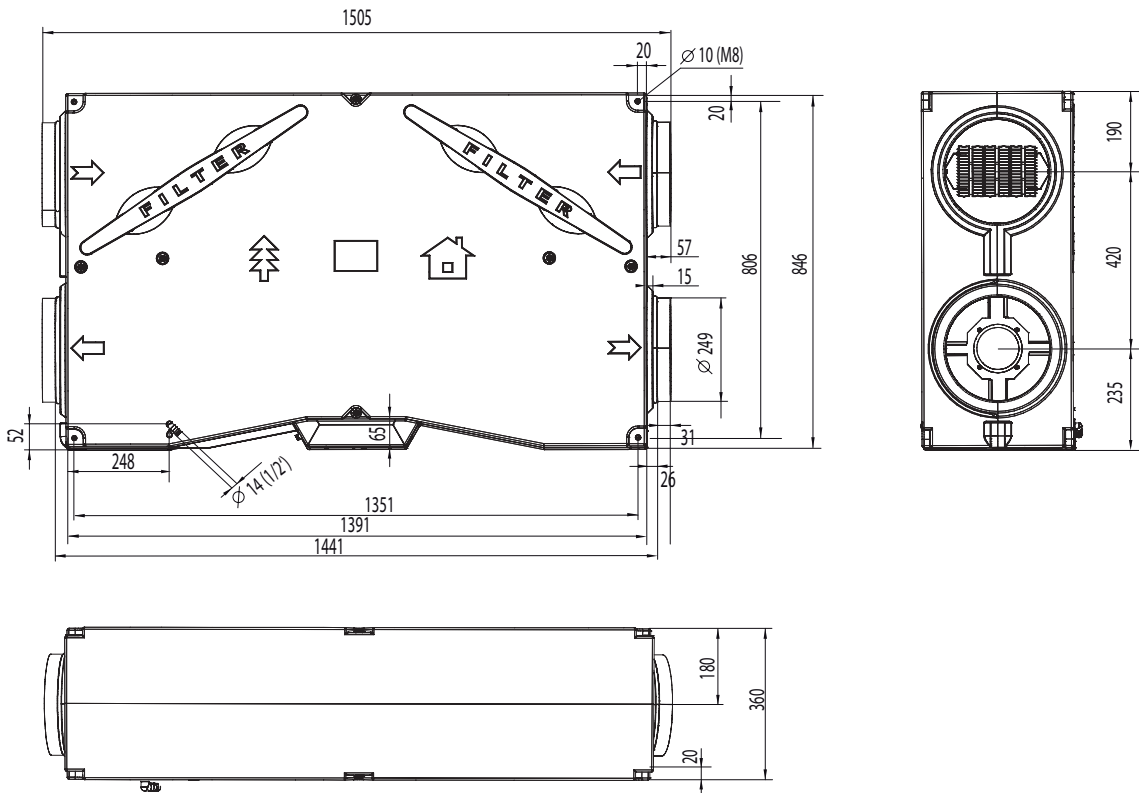

5. TECHNICAL PARAMETERS

Type	Maximum airflow [m³/h]	Supply filter class	Exhaust filter class	Phase [pcs]	Voltage [V]	Frequency [Hz]	Fan power [W]	Pre-heater Input [kW]	Weight [kg]	L _p A at 3m [dB]	Noise surroundings L _w A [dB]	Noise suction supply L _w A [dB]	Noise suction exhaust L _w A [dB]	Duct diameter [mm]	Unit height [mm]	Unit width [mm]	Unit length [mm]
HRV15AC	185	M5+G2	G4	1	230	50	105	1,0	17,4	37,3	58,6	55,1	64,8	160	270	555	1000
HRV30AC	265	M5+G2	G4	1	230	50	145	1,3	19,5	38,9	60,2	58,9	66,4	160	270	555	1000
HRV50AC	515	M5+G2	G4	1	230	50	230	2,5	35	47,1	68,8	59	69,6	250	360	846	1391
HRV70AC	650	M5+G2	G4	1	230	50	270	2,5	40	42,9	64,5	59,1	67,3	250	360	846	1391

Airflow output characteristic

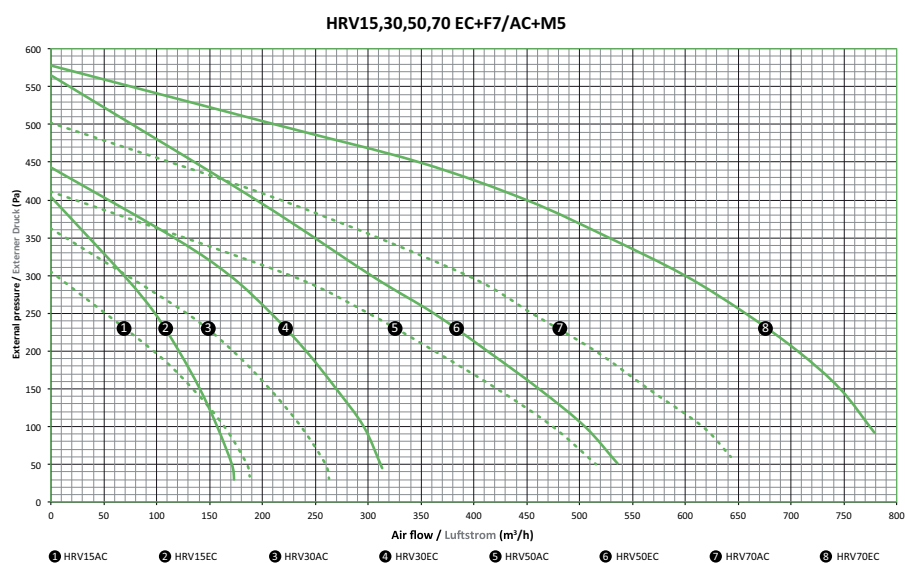

6. INSTALLATION

6.1 CHOOSE THE PLACE OF INSTALLATION

THE VENTILATION UNIT PROJECT SHALL ALWAYS BE DEVELOPER BY THE HVAC DESIGNER.

TECHNICAL INFORMATION

It must be operated inside covered and dry areas with a room temperature ranging from +5°C up to +40°C.

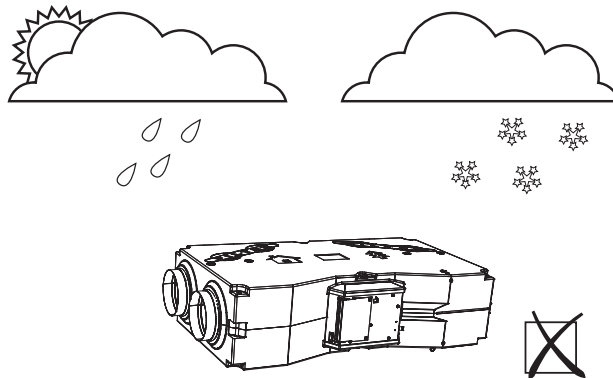
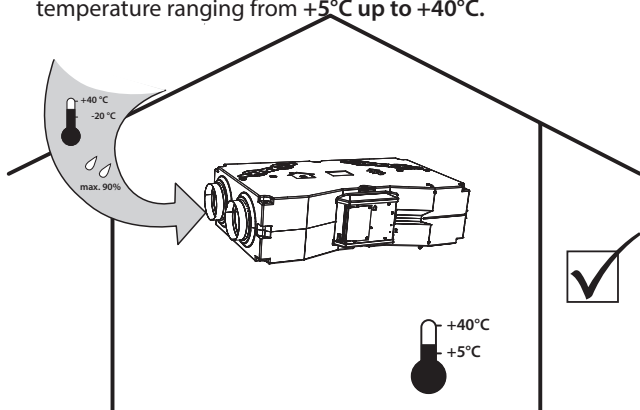

The filtered air should have a temperature ranging from -20°C up to +40°C and relative humidity up to 90%.

6. INSTALLATION

The unit is not designed for the filtration of air containing flammable or combustible compounds, chemical fumes, rough dust, black carbon, grease, poisons, germs etc.

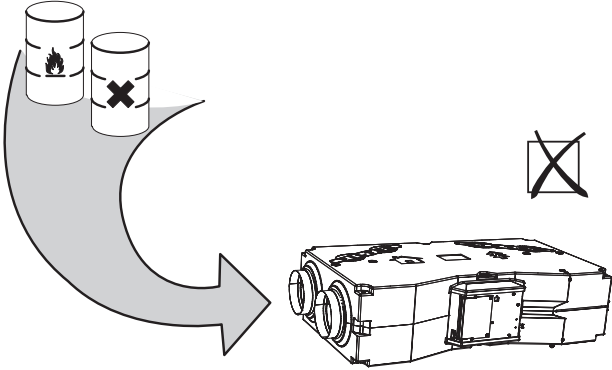

IP protection of the unit mounted into the pipelines is the IP 20 type (protection against objects larger than 12.5 mm, not protected from water!)

6.1-1 Built up dimensions

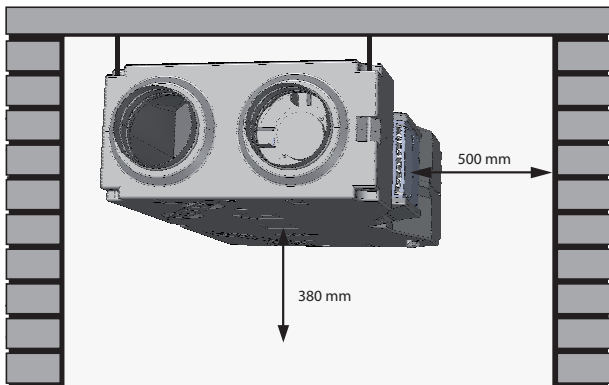

- These dimensions are recommended for servicing access.

TECHNICAL INFORMATION

- All types of ventilation units can be installed in following positions:

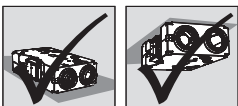

- Any other position is prohibited.



- The unit must be installed in such a way that the direction of the air flow throughout the unit corresponds with the air flow in the distribution system.
- The unit installation must allow for sufficient access for maintenance, service purposes or its dismantling. The access mainly concerns the revision lids allowing their opening.

6.1.-2 Required distances

ATTENTION

Non-flammable materials must not obstruct the suction and exhaust openings.

- The safe distance of flammable materials from the entry neck of the unit is 500 mm.
- The safe distance of flammable materials in the remaining directions is 100 mm.

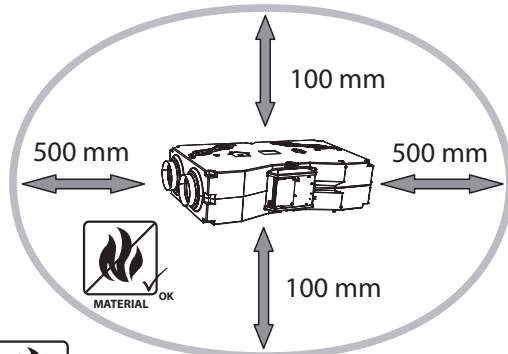

6.1.-3 Mounting of the unit

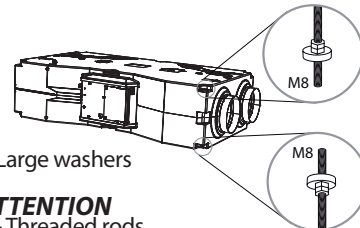
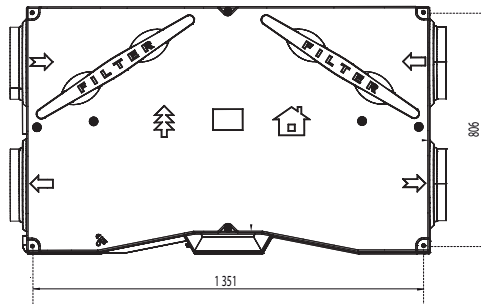
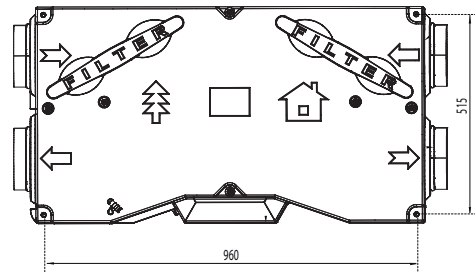

- 8xM8 Large washers
- 4xM8 - Threaded rods
- 16xM8 Nut (not supplied in delivery)

ATTENTION

6. INSTALLATION

- Measure up the place of installation
- Drill the holes into the wall and hang the unit on threaded bars on all corners of the unit.

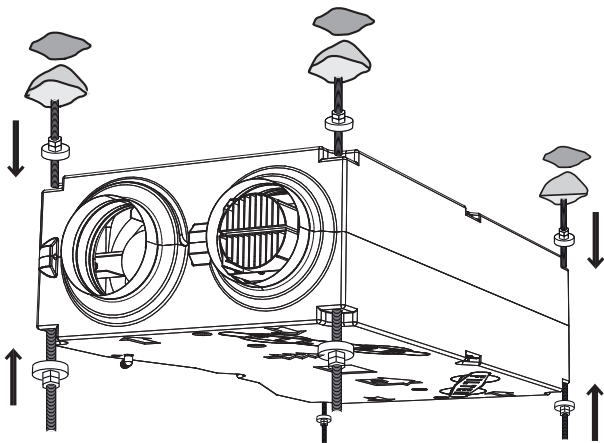

! ATTENTION

- Threaded rods must be able to take the weight of the unit!
- Considering the weight of the unit, it is necessary to use suitable lifting equipment (a fork lift truck etc.) or use two or more persons who will hold it up until it is safely mounted



YOU WILL NEED

- 4 wall plugs according to type and size of the screw (also depending on the ceiling material and the weight of the unit)
- Electric drill and drills of the relevant size

6.2 CONNECTING THE CONDENSATION WATER OUTLET



YOU WILL NEED

- drain hose 1/2"

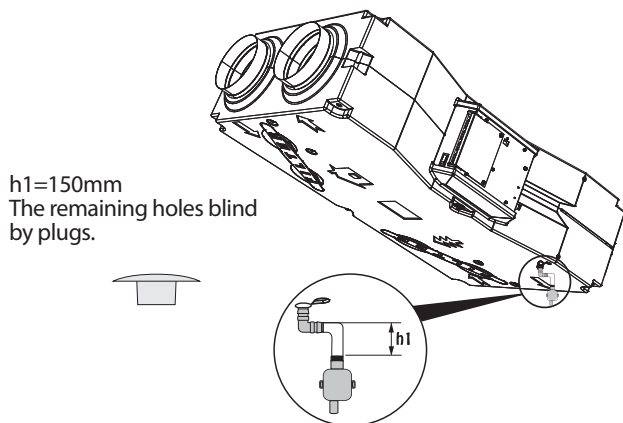

$h_1=150\text{mm}$
The remaining holes blind by plugs.

Connect the siphon on to the neck and the drain pipe which will lead to the sewerage system.



DO NOT MISS!

- Check whether the unit is tilted so the condensate may run off freely (we suggest 5° tilt, see the figure below).
- The siphon must be connected and sealed properly in the heat exchange unit.



ATTENTION

IMPROPER CONNECTION OF THE SIPHON MAY CAUSE FLOODING AND DAMAGE TO THE HEAT EXCHANGE UNIT.

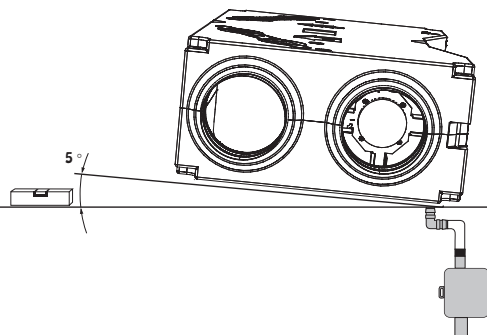

THE SIPHON (SK-HL138) MAY BE INSTALLED ON THE WALL OR CONCEALED.



DO NOT MISS!

Check the following prior to the first activation of the ventilation unit:

- That unit is correctly attached to the framework.
- That unit is closed properly, all of the necks are connected to the pipelines or protected with a grid and therefore there is no risk of injury from rotating or hot parts.
- Electrical connections must correspond with wiring diagram.
- That all electrical components are correctly connected.
- That condensation water outlet is connected to the drainage
- That installation corresponds with all instructions from this manual
- That there are no tools or other objects left inside the unit which could damage it.
- Whether unit includes a clean filters.



ATTENTION!

- Interventions and changes to the internal connection of the unit are prohibited, they may lead to warranty loss.
- We suggest using the accessories supplied by our company. In case of any doubts in use of the original accessories please contact the supplier.

6. INSTALLATION

6.3 CONNECTING THE AIR PIPING

6.3-1 Flexible connection

Connect the pipes to the exhaust and the suction necks using flexible connections to stop the transfer of vibrations and it allows easier removal of the unit from the installation place when servicing.

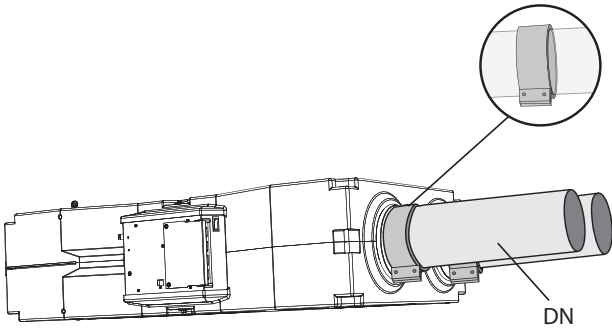

Type	DN
HRV15AC	160
HRV30AC	160
HRV50AC	250
HRV70AC	250



YOU WILL NEED

- Side nut wrenches
- 4 flexible connection sleeves
- Cross head screwdriver
- Sealing tape, sealant



DO NOT MISS!

- The connected pipes must be of the same diameter as the exhaust and suction necks. If pipes of a smaller diameter will be used, the unit performance could drop and in some cases the lifespan of the ventilators could also decrease.
- Any joints between the air distribution pipes and the unit must be sealed using a sealant or a sealing tape.
- The minimum distance of the bent air pipes or adapting pieces from the unit neck should be 500 mm.

6.3-2 Protective grid

In the event that some of the necks of the unit will not be used for connecting pipes, it is necessary to fix the opening with a grid for protection from touching the rotating parts of ventilator, heater bars etc..

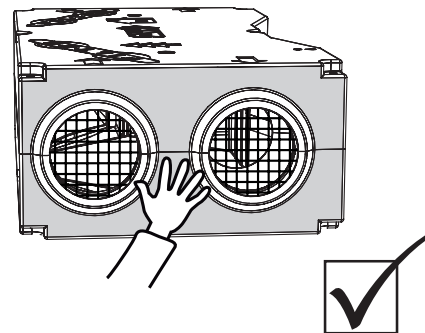
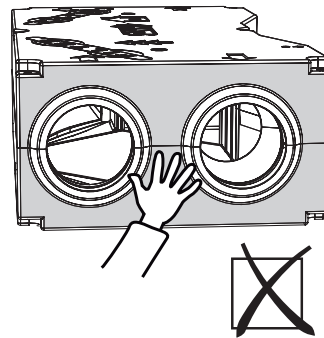

6. INSTALLATION

6.4.ELECTROINSTALLATION AND ELECTRICAL FITTINGS

⚠ ATTENTION

- The main electrical supply must be turned off prior to any interference with the internal parts of the ventilation unit!
- The electro installation of the ventilation unit must be implemented according to the technical documentation issued by a qualified electro engineer. The actual installation can be carried out by a professional educated in the electro field. The manual instructions must be observed as well as the valid national regulations and directives.
- The electrical charts featured on the product have a higher priority than the charts included in the manual! Prior to installation, check if the marking of the terminals conform to the electrical chart for connection. In the event of any doubts, contact your supplier and under no circumstances should you connect the ventilation unit.
- The unit must be connected to the power supply using insulated fixed and temperature resistant cable according to the diameter and the relevant national regulations and directives.
- Any interference and amendments into the internal connection of the unit are prohibited and can lead to a loss of the warranty service.
- Correct unit functioning is guaranteed only with original fittings

6.4-1 Electrical power cord

The connecting terminal board of the electrical power cord is positioned in the regulation box

⚙ TECHNICAL INFORMATION

- The electrical parameters are stated on the manufacturer's label

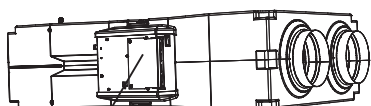

Product type	
U = power supply	I = current
F = frequency	P = wattage
N = vent. revolutions	M = weight
Ph = number of phases	IP = el. protection
Av = air flow	Ver =
Serial number	

The heat recovery unit must be connected using the TN-S system which means that the neutral wire must always be connected. All electrical circuits into the heat recovery unit must be connected via a protective power circuitbreaker according to the current and type. The distance in between the open contacts must be bigger than 3mm. Heat recovery unit must be connected in such a manner so it can be disconnected from the power supply via a single element. Table of the minimum dimensioning of the power supply cables and circuit breakers according to the type of

heat recovery unit.

Recommended circuit breakers

Circuit breakers	
HRV15AC	10A, 1ph
HRV30AC	10A, 1ph
HRV50AC	16A, 1ph
HRV70AC	16A, 1ph

6.4-2 Electrical fittings

Connect the unit electrical fittings to the terminal inside the regulator box exactly according to the el. diagram for connection and according to the markings of the terminals.

🔍 DO NOT MISS!

- The connection diagram is glued to the internal side of the removable lid of the regulator box.
- Each element must be connected using an original cable or cable as per the specification for each element.
- To open the lid of the regulator box you will need 2,5mm imbus key. See picture.

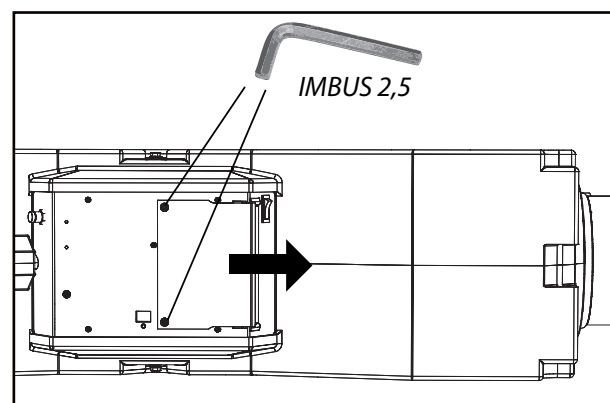

6. INSTALLATION

Electric scheme for power supply and accessories connection.

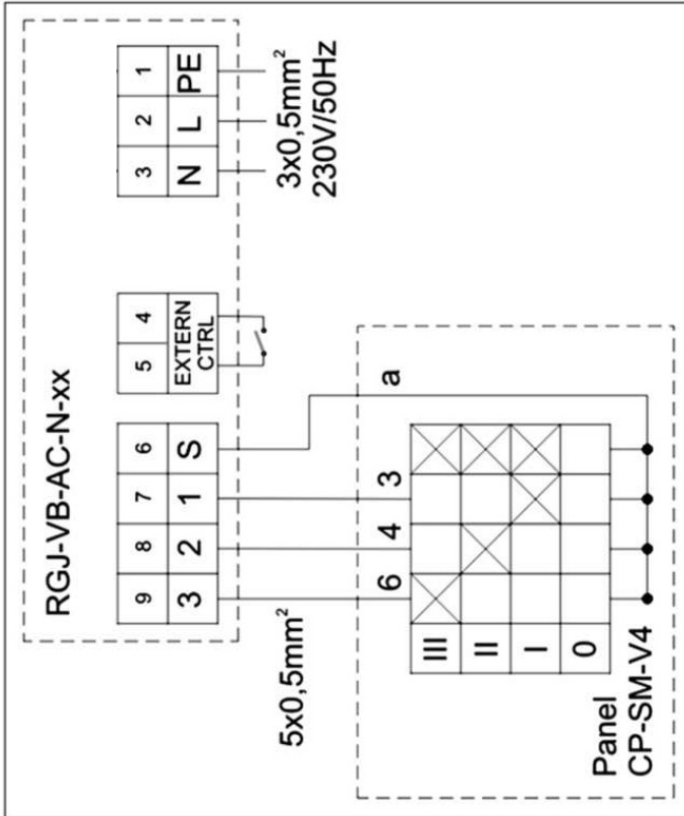

WITH TIMER SWITCH

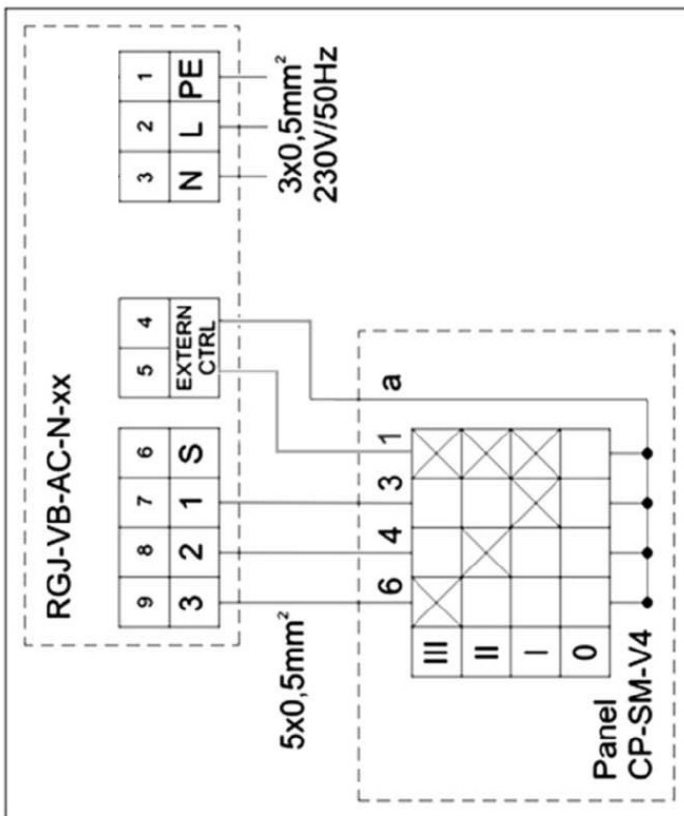

WITHOUT TIMER SWITCH

7. FREECOOLING

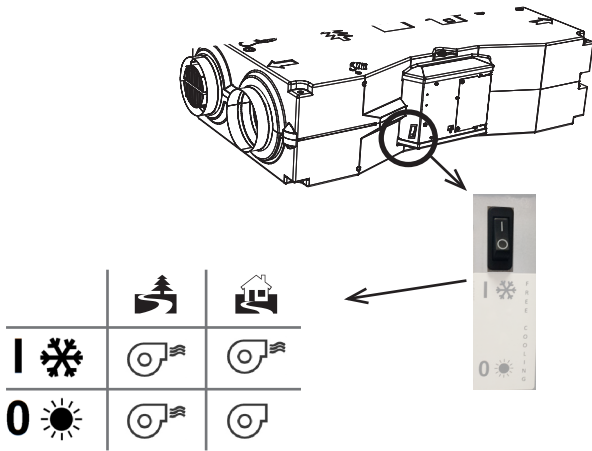

8. MAINTENANCE

8.2 PERIODICAL CLEANING OF THE VENTILATION UNIT

We suggest regular inspections of the ventilation unit in the interval that must be adjusted depending on current conditions. In case the unit is not in operation for a longer period of time, we suggest activation of the unit for 1 hour operation at least every six months.

⚠ ATTENTION

Service of internal components and cleaning of the unit must be carried out by professional service shop only! Operation of the unit without the filter is not allowed! Otherwise the heat exchanger can be damaged!!!

For this maintenance it is always necessary to remove unit from the working position - there is a risk of injury.

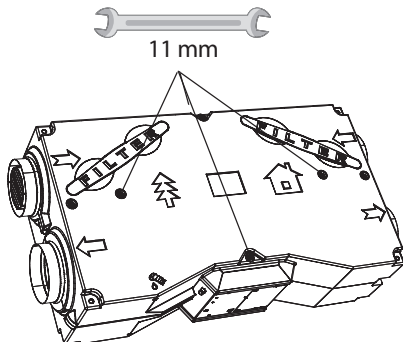

8. MAINTENANCE

Disassembly of the unit only in exceptional cases!!!

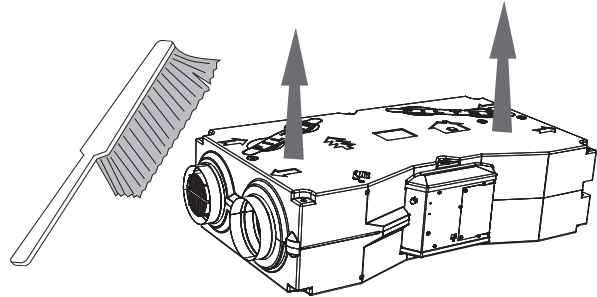

Clean the ventilation unit, using a vacuum-cleaner, small brush, cloth and soapy water especially recuperator. Do not clean the unit with following: Sharp objects, aggressive chemicals, solvents, abrasive cleaning products, pressured water, pressured air or steam.

8.3 CLOGGED FILTER

- The control of filter clogging is indicated with an LED located on the cover of regulation box.

LED status	Clogged filter	Triggering diode
Blinking	on 80%	after 48 days worked
ON	on 100%	after 60 days worked

- After checking filters or replacing them, it is necessary to restart the filter clogging timer using the RESET button.

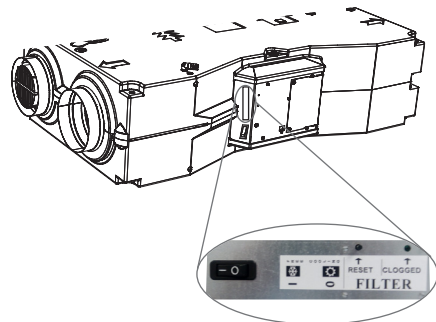

8.4. SIGNALIZATION

Signalization is provided by green LED which can be found under the lid of regulation box.

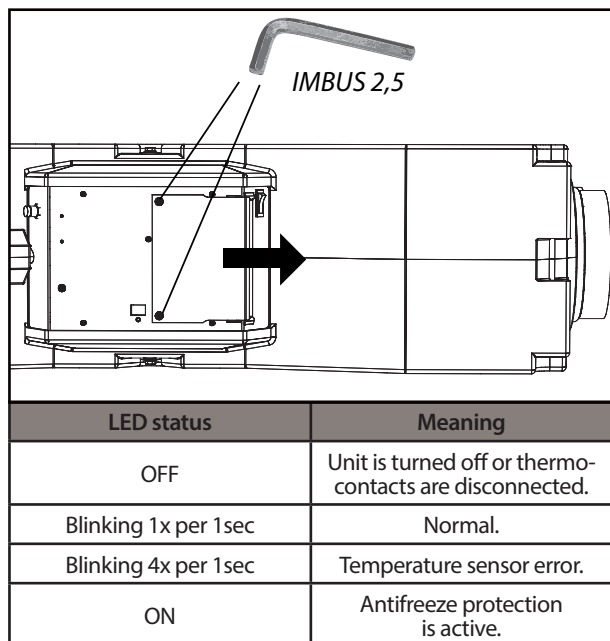

DO NOT MISS!

When there is an error or fail signalled, we recommend to contact a service company.

9. ACCESSORIES



When the installation of the unit is completed, carefully read the safe operation manual for the ventilation unit. This manual also contains examples of potential problems and recommendations for their solution. In the event of any queries or questions, please do not hesitate to contact our sales department or our technical support department.

Accessories:

Accessories	HRV15	HRV30	HRV50	HRV70
Spatial relative humidity	CI-ADS-RH-24			
Spatial CO ₂ sensor	CI-ASCO2-GR			
PIR sensor	CI-PS 1003			
Timer with a weekly program	SH-TM-848			
Spare filter G4	HRV-30-FI-G4	HRV-30-FI-G4	HRV-70-FI-G4	HRV-70-FI-G4
Spare filter F5	HRV-30-FI-M5	HRV-30-FI-M5	HRV-70-FI-M5	HRV-70-FI-M5
Spare filter F7	HRV-30-FI-F7	HRV-30-FI-F7	HRV-70-FI-F7	HRV-70-FI-F7
Controller	CP-SM-V4			
Siphon	SK-HL138			
Connection sleeve	MK160		MK 250	

**Dismantling of the motor**

disengaging the mount from the assembly - bit square prism bit No.2

Phillips



disengaging the motor from the mount - hex key but No. 2.5 mm

**Surface joint**

opening the plate flathead screwdriver

Removing the plate from the spacers (electronics groove) - pliers for precision mechanics

disengaging the sheet like plate - Phillips screw No.0

**Plastic components**

blanket insulation of the front panels - breaking knife

CONTACT**Address**

2VV, s.r.o.,
Fáblovka 568,
533 52 Pardubice,
Czech Republic

Internet

<http://www.2vv.cz/>

